

EFFLUENT

# SDI-E

Subsurface Drip Irrigation  
For Dairy Effluent Water Application

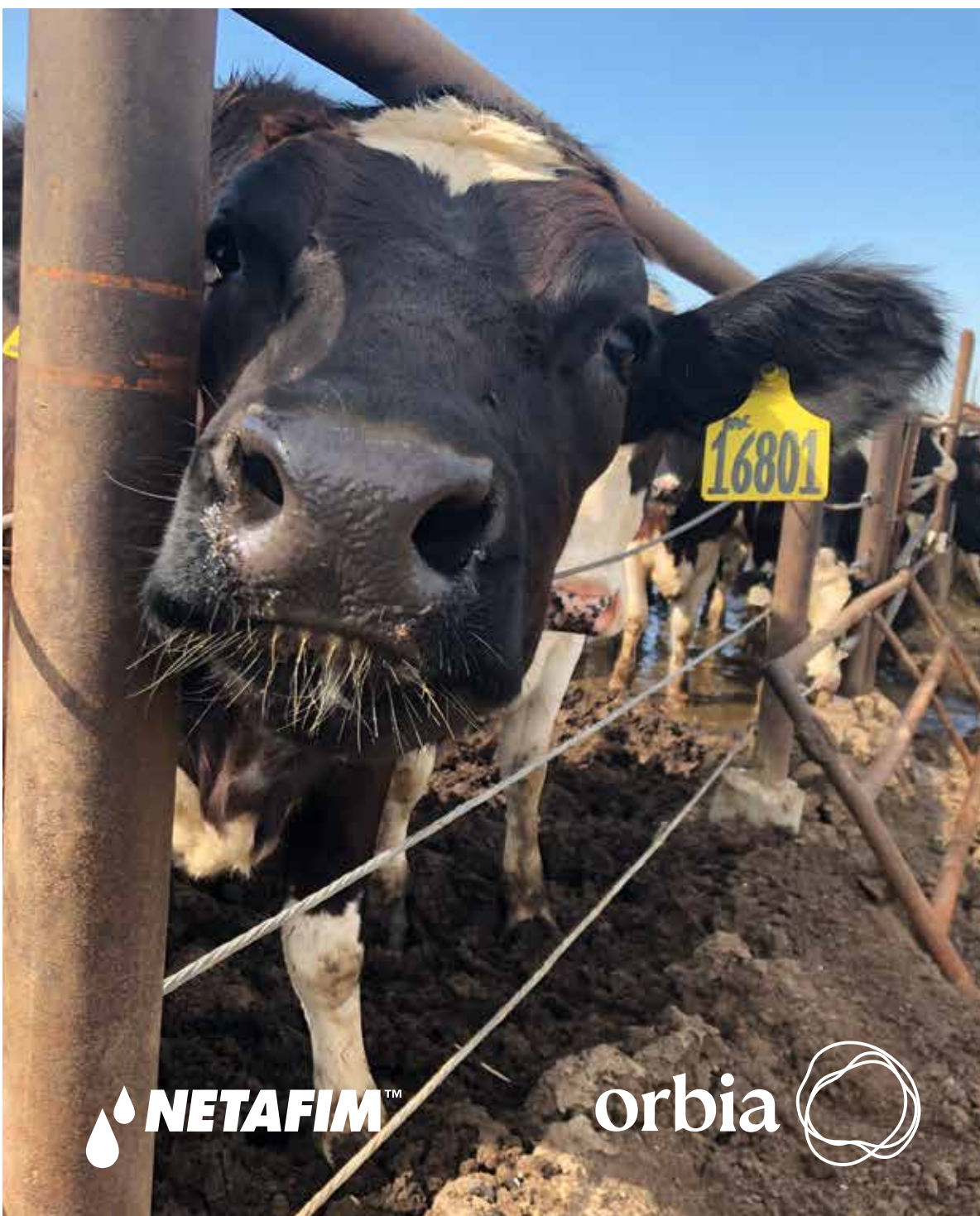



2022   
VANGUARD  
AWARD Recipient  
Irrigation Association

# 2020 U.S. DAIRY SUSTAINABILITY AWARDS

## Effluent Subsurface Drip Irrigation Solution for Dairies receives 2020 U.S. Dairy Sustainability Award for Outstanding Community Impact.

### The Power of Partnerships for Innovation and Environmental Wins

Strategic collaboration fuels creative and innovative solutions, in this case the partners involved developed a sustainable solution to help dairies manage manure waste, creating a closed loop system in dairy manure management.

### The Challenge

Dairy Farmers needed a solution to manage manure waste, utilizing it to fertilize feed crops. At the same time, the California drought pushed for solutions to use water more efficiently.

### The Solution - Making an Impact

SDI-E, an innovative subsurface drip system utilizes advanced filtration and proprietary, patent-pending technology developed by Netafim to blend dairy wastewater with fresh water enabling consistent and reliable application of dairy effluent as a nutrient-rich fertilizer. This process not only re-uses water, but also recycles manure as a natural crop nutrient and soil builder, reducing the need for commercial fertilizer.

In addition to the water savings provided by drip irrigation, field trials have shown an increase in nitrogen use efficiency of up to 47 percent. This results in more of this organic fertilizer being taken up by the plant, preventing the leaching of excess nutrients from the soil to the groundwater below. The system has also shown to help decrease the emission of greenhouse gases.



[Learn More](#)



Partners



DE JAGER  
DAIRY

MCREE  
DAIRY



## TABLE OF CONTENTS

Subsurface Drip System Overview	4
Why Subsurface Drip Irrigation?	5
Critical Aspects to Consider	5
Benefits of Effluent Water Application	6
Drip System Components	
Basic System Layout	8
Pump Requirements for Blending	9
Water Meter, Pressure Guage, and Mixing Valves	11
Filtration	12
Controller, Monitor, and Sensors	13
Fertilizer and Chemical Injection	14
Valves, Manifolds and Air Vents	15
Dripline and Flush Manifolds	16
Applying Effluent Water	
Nutrigation™	17
UC Co-Op Technical Guide	
Application	18
Water Sampling	19
Maintenance Scheduling	23



**Subsurface Drip Irrigation (SDI) is defined as the application of water below the soil surface by micro-irrigation emitters. SDI has been used commercially for irrigating many crops since the early 1990s.**

In most applications dripline spacing is defined by the crop rotation on the farm. System design considerations should include the requirements of growing both corn, winter forage systems, and alfalfa production. Common spacings today are 30", 40" and 60". The dripline is typically buried 8 to 14 inches deep depending upon soil type and germination conditions. The placement of the dripline every other plant row is an economic setup for agricultural production. The spacing between emitters and flow rate per emitter is determined by the soil properties, crop rooting depth, and other local aspects.

The most common method for the scheduling of irrigation events are based on crop water use as determined by evapotranspiration (ET). However, incorporating the use of ET based scheduling and backing that up with soil moisture sensors, is becoming more and more popular.

SDI is a management tool that allows precise control over the root zone environment of your crop. This added management control results in consistently higher yields and better quality. In addition, better water and nutrient management can help reduce fertilizer inputs, water needs, and runoff.

The purpose of this manual is to describe the layout, installation, operation and maintenance of an SDI-E system. It is meant as a guide to aid in the decision to move to drip technology and how to manage this technology to obtain the desired results.



Your Authorized Netafim Digital Farming Dealer, versed in the local aspects of crops irrigation with SDI, will help determine what system configuration is best.



Scan to find an Authorized Digital Farming Dealer or visit [www.netafimusa.com](http://www.netafimusa.com)



Alfalfa Field



Double Row Corn Planting



SDI-E Filter Station

## Highest Water Use Efficiency of Any Irrigation System

Water loss through evaporation, runoff and deep percolation are virtually eliminated.

## Improves Crop Quality and Bottom Line Results

Water and nutrients are used more efficiently reducing input costs, and produces a more uniform crop and higher yields.

## Adapts For Field Size, Shape and Topography

Odd shaped, small, and steep fields are not an issue with Netafim SDI solutions.

## Long Lasting Performance

A high-quality drip system can last up to 25 years or more, when properly maintained.

## Subsurface Drip Irrigation Reduces Cultivation Costs

SDI is the most efficient irrigation system using less water and fertilizer, saving operational expenses. Drip is well adapted to 'No-till, Strip-till, and Minimum till' systems reducing cultivation costs.



- Precise Application of nutrients to Root System
- Less fertilizer.



- Use on-farm nutrients to fertilize forage crops
- Reduces synthetic fertilizer cost



- Soil surface stays dry
- Less weed growth



- Using SDI with strip or no-till streamlines crop management strategy
- Reduces time for ground preparation, cultivation and crop residue management.



- SDI irrigates 100% of the land.
- No corners as with center pivot irrigation.

## Critical Aspects That Need To Be Considered



ROI in two to three years.



Use **sprinkler or flood irrigation** for Seed Germination and Stand Establishment.

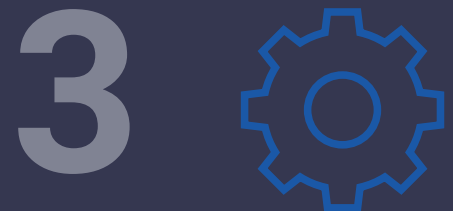

Perform **regular maintenance** to ensure SDI system is performing to specification.

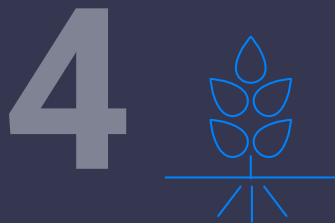

SDI is a watering device and a **root zone management** tool. Requiring careful records of crop and system activity.

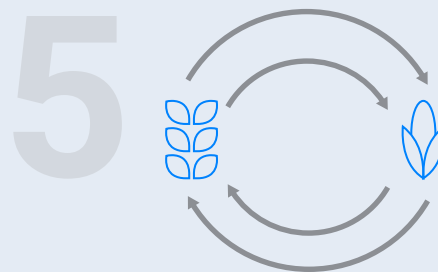

When formulating a plan for SDI, you must consider **crop rotation and cultivation practices** such as deep cultivation.



Rodents can damage your crop and the drip system. A **rodent management plan** is recommended.



Questions? Email us [netafim.usa@netafim.com](mailto:netafim.usa@netafim.com).



Download  
Rodent  
Management  
Guide.

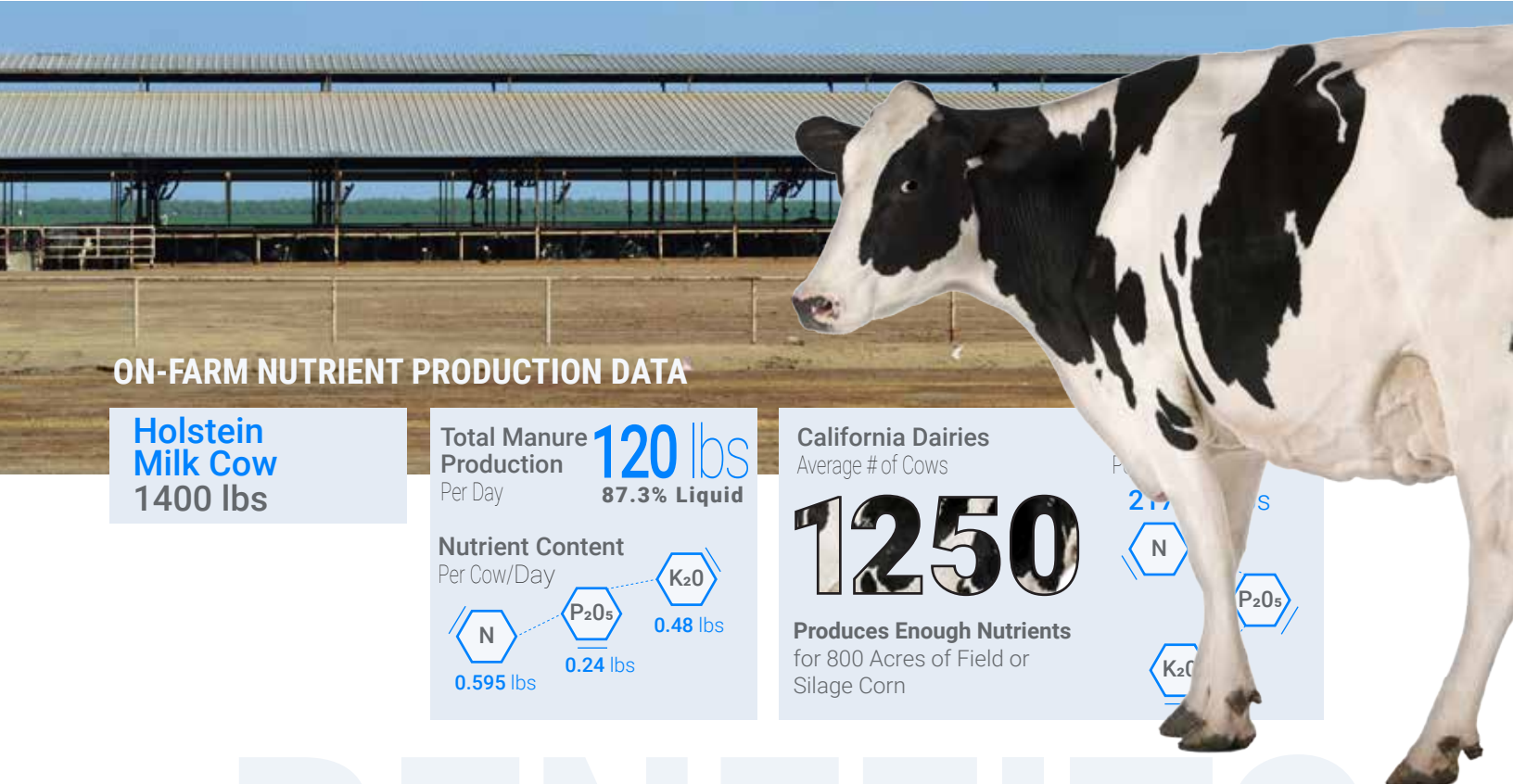

ON-FARM NUTRIENT PRODUCTION DATA

**Holstein Milk Cow**  
1400 lbs

Total Manure Production **120 lbs**  
Per Day **87.3% Liquid**

Nutrient Content Per Cow/Day

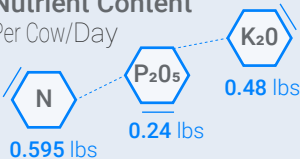

California Dairies Average # of Cows

**1250**

Produces Enough Nutrients for 800 Acres of Field or Silage Corn

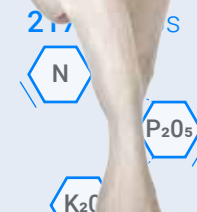

UTILIZATION OF ON-FARM NUTRIENTS

**BETTER HEALTHIER ROOT ENVIRONMENT**

In the case of dairy effluent and freshwater blend is applied directly to the roots as the water expands outward in all directions from the drippers.



**WATER CONSERVATION**

By applying an effluent water freshwater mix directly to the root zone via SDI, evaporation is almost totally eliminated. No moisture on soil surface means less weed growth and less cultivation or herbicide sprays.

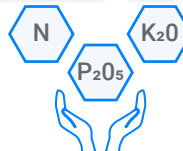

**NUTRIENT CONSERVATION**

Coordinating timing of nutrient distribution with plant uptake can reduce the amount of nutrients applied. With drip, nutrients are applied directly to the roots becoming quickly available to the crop.



**ENERGY CONSERVATION**

Typically, SDI gives the ability to reduce overall amount of nutrients being applied, because it is applied with better timing coordinated with plant uptake. Nutrients are applied directly to the roots, becoming quickly available to the crop.

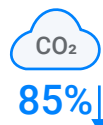

**GREENHOUSE GAS EMISSIONS**

In side by side studies in Madera County California by Marten Berger et al, UC Davis, approximately 70-90% fewer greenhouse gases were released, when dairy effluent water was applied through a SDI system.

DAIRY EFFLUENT WATER APPLICATION DISTRIBUTION UNIFORMITY (DU)

**90% DU** Subsurface Drip Irrigation

Nutrients are applied more evenly along the drip lateral with better control. Saturation is avoided. Applying on-farm nutrients through drip reduces the risk of leaching of nitrates and other compounds into the groundwater supply.

**40-50% DU** Border Check Flood Irrigation

As dairy effluent water is applied the solids start to pile up at the head end of the field lowering the DU even more as irrigation proceeds, resulting in more nutrients applied to the head of the field.



### Overview

This section of the manual reviews the layout and function of the components required for a typical Subsurface Drip Irrigation (SDI) system.

In SDI, the dripline is permanently buried about 12 inches deep supplying water to, and feeding the roots directly. The longevity of your system will depend on factors such as initial water quality, proper operation, regular maintenance and control of rodent populations.

Water sources currently used for flood or sprinkler irrigation are generally suitable for drip irrigation. With the ever-growing demand for water resources, farmers are turning to recycled water sources, including municipal and industrial wastewater and nutrient-rich water from dairy operations. However, there are special considerations required to ensure the longevity of the drip irrigation system, especially when using nutrient-rich water such as dairy effluent.

Regardless of the water source or sources, you plan to use, the first step in any SDI System design is to collect a sample of the principle water source (freshwater) and have it analyzed for Drip Irrigation Suitability. Water quality issues can be addressed through proper system design and water treatment, but it is most cost-effective to do this as the first step in design.

Maintenance procedures may also need to be adjusted for specific water conditions, such as increase flushing velocities and frequencies. Specific water quality issues are discussed in more details in the operations and maintenance section of this manual.

Application of nutrient-rich effluent water from dairy and swine operations requires more intensive sampling due to variability and will be discussed later in this manual.



### Basic System Layout

**The heart of the system is the dripline, pressure compensating or non-pressure compensating emitters are used depending upon row length and field topography.**

As the name suggests, pressure compensating emitters produce the same flow rate over a wide range of pressures while the flow rate for non-compensating emitter is a function of the inlet pressure. Pressure compensating emitters are generally more complex and hence more expensive than non-compensating emitters. On sloping terrain, pressure compensating emitters allow uniform water distribution even though the slope will result in large pressure gradients. This can result in significant water savings and improved yield by producing a more uniform crop.

To protect the dripline a high-quality filtration system is recommended. This is typically a media filtration system. Maintaining the dripline over the long term requires a system for injecting chemicals. It is also possible to use this injection system to supply fertilizers directly to the crop roots. Although, when applying effluent water, another method of dosing will be discussed in detail later on in this manual, supplying nutrients directly to the roots is the most efficient and effective way to fertilize the crop. Pipeline, pressure regulating valves, sub-mains, air/vacuum relief valves and control round out the rest of the system. Your Authorized Netafim Dealer is trained in system design and installation of quality SDI systems. Still it's important to understand how the system is put together and why certain design elements are specified.

### Schematic Of A Typical SDI System Components.

(This illustration does not represent an SDI-E System)

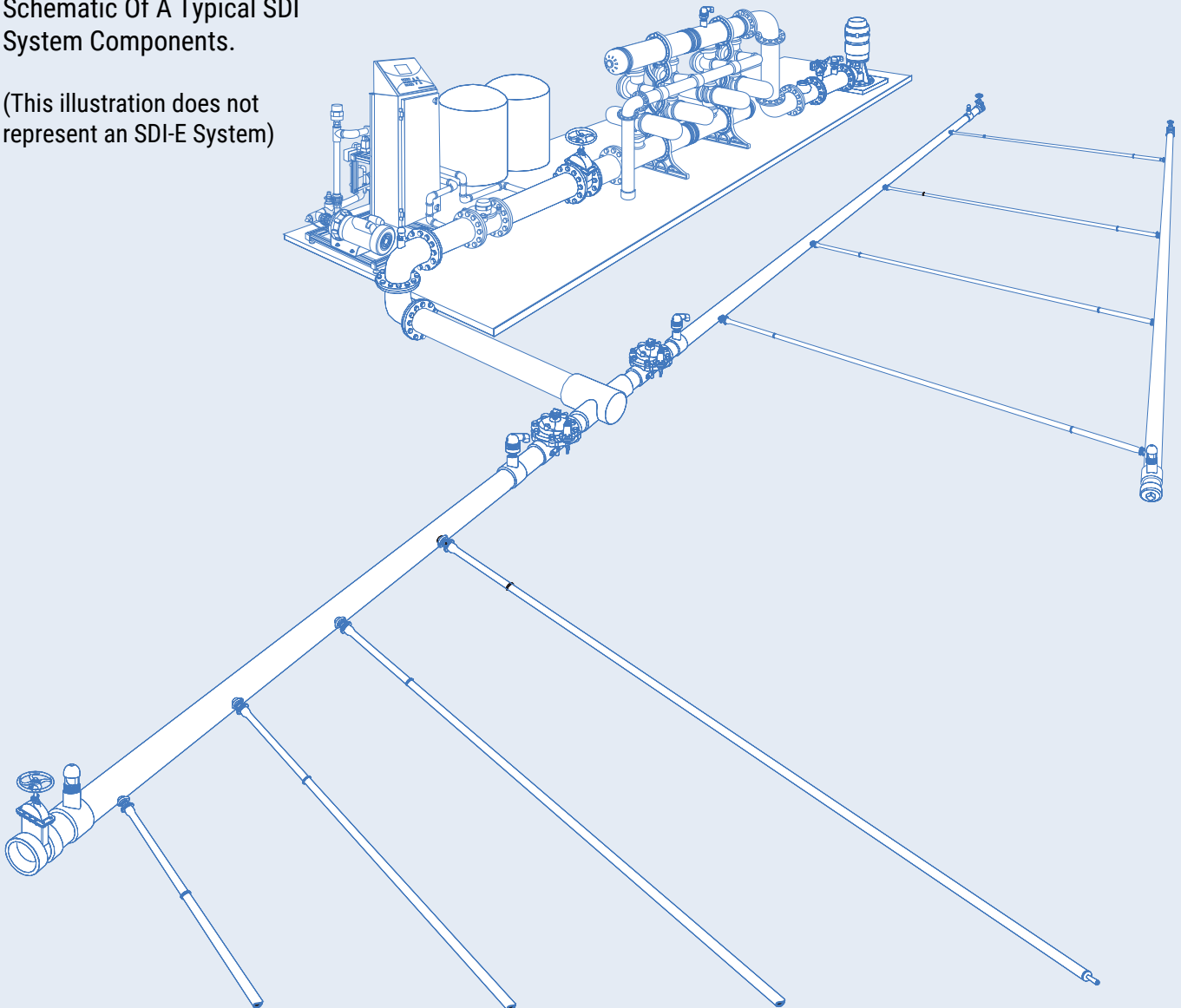



## Importance Of Evaluating The Quality Of Manure Separation Prior To Intake Into The SDI-E System

In preparation for installing the manure SDI system, a review of the dairy's manure management system is recommended. Flood irrigation systems on dairies can generally tolerate substantial amounts of coarse manure solids and still apply the fresh water and manure effluent blend to the fields. To convert to manure SDI, retrofits to the manure management system may be needed to reduce the concentration of coarse solids.

### Blending Dairy Effluent and Fresh Water

Fresh water is delivered to a booster at the head end of the filter station. Effluent water is delivered to a lift pump via a wet well alongside the lagoon. A traveling screen is installed as a prefilter to keep any floating or large debris in the lagoon from entering the wet well.

Booster pumps are operated by variable frequency drives. The two booster pumps deliver fresh or effluent water to the filter station, sand media filtration does the filtering job. Each booster has its own flow meter measuring flow and collecting data.



### Pump Requirements

Pump requirements when applying nutrient-rich effluent water are different because of the need to blend the effluent water further with fresh water. This blending is automatically adjusting the mix ratio to the ever-changing turbidity or suspended material in the water column.

When applying an effluent water mix, the system has two pumps. The first pump is typically set up for a drip irrigation system, except for the addition of a Variable Frequency Drive (VFD) panel. The second pump, smaller than the first pump only pumps effluent water and is also set up with a VFD panel. The reason to incorporate Variable Frequency Drive is clearly driven by energy savings and second by the ease of system operation.

### Typical Pump Flow Ratio When Applying Effluent Water

Design Flow (GPM)	=	Fresh Water (GPM)	+	Manure Water (GPM)
1000		1000		0
1000		900		100
1000		800		200
1000		700		300
1000		600		400
1000		500		500

The system mixes up to a 50:50 ratio of effluent water/freshwater as delivered to the pump and filter station by the dairy. Netafim utilizes a patented system for mixing or blending of water controlled automatically by the Netafim controller (NMC-Pro) which is connected to an Electric Conductivity (EC) Sensor measuring the salt load of the blended water, adjusting the mixing valve to the proper proportion of fresh and effluent water.

Blending will be discussed in more detail in the section, Applying Nutrient-rich Effluent Water, of this manual.

The volume output of the pumping station dictates the amount of area that can be irrigated. A simple formula has been derived converting the ET in inches of water per day per acre into gallons per minute per acre.

<b>Formula:</b>	Evapotranspiration (ET)	=	Inches of Water per Day/per Acre	x	18.86 (Conversion Factor)	=	GPM/Acre
<b>Example:</b>	Evapotranspiration (ET)	=	.25" Inches of Water per Day/per Acre	x	18.86 (Conversion Factor)	=	4.72 GPM/Acre

This calculation is for a pump running 24 hours. More commonly as a safety factor, systems are sized for 20 hours of operation. To accomplish this, use the following formula:

<b>Formula:</b>	$\frac{24 \text{ Hours}}{\# \text{ of Hours for Irrigation}}$	x	4.72 GPM/Acre	=	GPM/Acre	<b>Example:</b>	$\frac{24}{20}$	x	4.72 GPM/Acre	=	5.66 GPM/Acre
-----------------	---	---	---------------	---	----------	-----------------	-----------------	---	---------------	---	---------------



**As per United States Patent No. 10143130:**

The waters are mixed proportionally based on the EC of the water measured downstream of the Mixing Valve. The NMC EC Pre-Control target is set in the dosing program. The NMC reads data delivered to it by the sensor transmitter, reacting by either opening the mixing valve to increase the EC level or by closing the mixing valve to reduce the EC level in the mix going to the field. Fresh and Nutrient-Rich Effluent Water samples are taken and analyses are done to determine nutrient content. The water is again measured as it goes out to the field by the Main Flow Meter. The manager adjusts EC (Nutrient Level) based on samples taken.

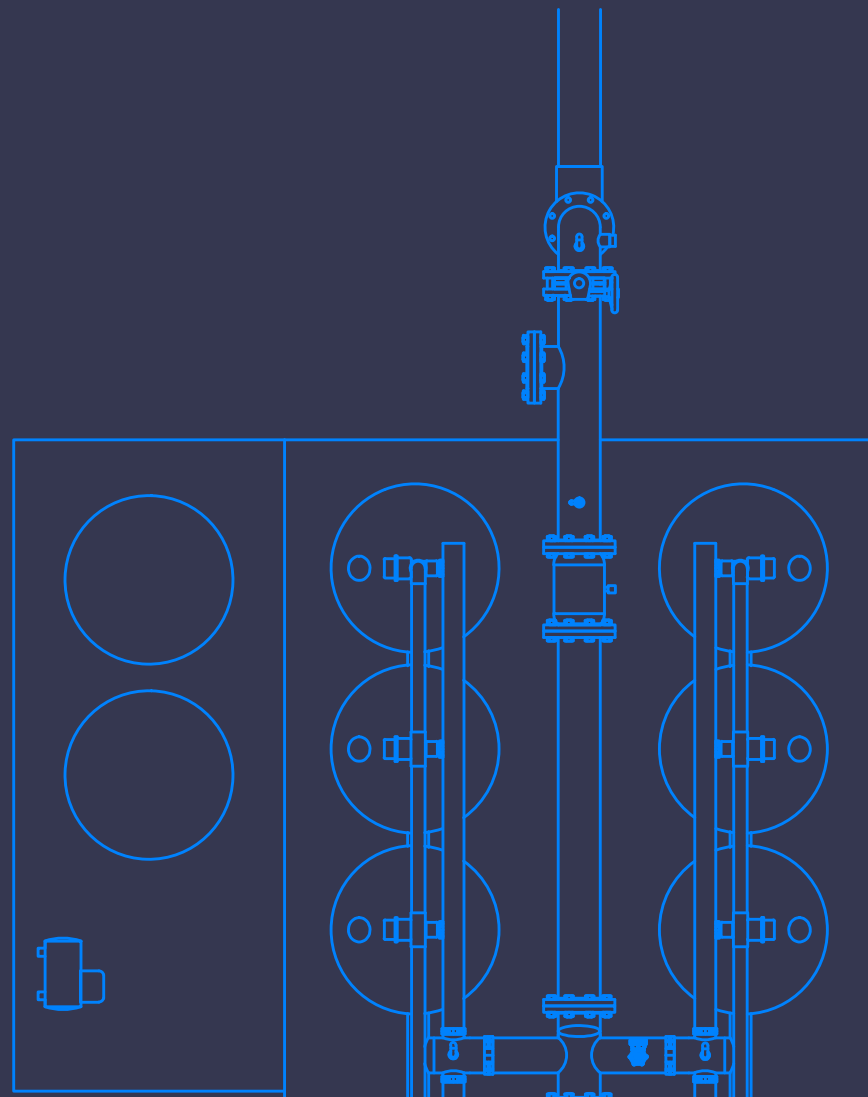



## Water Meters

It is essential to monitor flow in order to monitor the operation of your system and crop water use. The SDI system is designed to produce a specific flow rate at a given pressure. Changes in the flow rate may indicate leaks in the system, emitter plugging, improperly set pressure regulating valves or even changes in the well and pumping plant.

## Application and Blending

Application of effluent water from Confined Animal Feeding Operations (CAFOs) requires the blending of freshwater with effluent water. For control purposes, we need to measure both the effluent and freshwater being delivered to the head control and also measure the water going out to the field. Therefore, in an effluent water application system, there would be three meters, the main meter measuring water ultimately being delivered to the crop and both effluent and freshwater meters measuring water coming into the system.



### Octave Water Meters

The Octave Ultrasonic Water Meter provides highly accurate flow readings with double-beam ultrasonic sensors and no impeller or moving parts in the flow path.

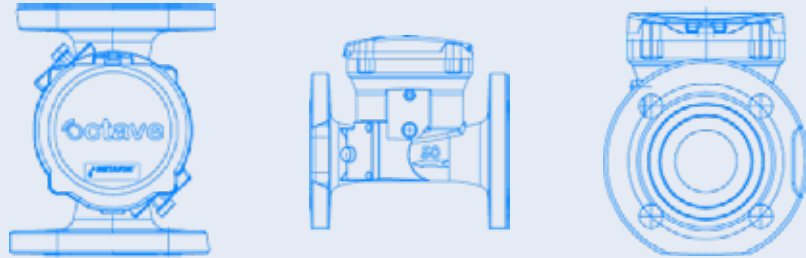

## Pressure Gauges

The use of pressure gauges in key locations on the system will help to ensure optimum performance and long life of your system.

## Mixing Valve

Envalve butterfly valves are designed to isolate or regulate flow. As they are electrically powered, they can be controlled remotely. The butterfly valves are made from PVC and have been provided with an EPDM gasket to enable them to withstand contact with corrosive substances. The valves are also available with Viton® gaskets if needed.

The axle is connected to an electric motor for convenient operation of the valve. This motor has a supply voltage of 24VAC. Motors with a supply voltage of 230 Volts are available on request. The motor can rotate bidirectionally and is controlled by the phase of the supply voltage. Alternating the phase causes the valve to open or close, respectively. The final position of the valve is limited by two built-in limit switches. The motors are bi-stable, which means that if the valve is rotating to a specific position and the power supply is cut off, the valve will remain in this position. An indicator in the motor shows the position of the valve (large or small flow-through). The motor is equipped with an unlock button that can disconnect the motor and move the valve manually into whatever position. The butterfly valves are provided with metric flanges and collars. The gasket also serves as a seal.



### Advantages

- Ample throughput capacity
- Low loss in pressure
- Bidirectional flow
- Little installation space needed
- Few parts
- Emergency manual operation override

### Specifications

- Run times of 70 or 130 seconds at a rotation angle of 90°.
- Comes with Metric Flanges (adapter to US Standard Flange is needed)
- Optional: extra limit switches and/or a heating element.

## Filtration

The filter system protects the drip system from the fine sand and other small particles that can plug the emitters. A well-conceived filter system provides the maximum operating life of the SDI system.

### Recommended Filtration Method - Sand Media Filters

Screen and Disc filters are not recommended for long term SDI-E systems.

**Sandstorm™ Single Chamber Metal Media**  
Built to last. Rugged tank design, industry-leading anti-corrosion and UV resistance provide long-term rust protection.

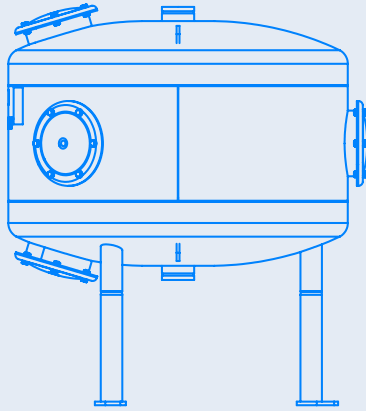

Sand media filters utilize depth filtration which is most effective at removing suspended particles from the water. The filter system should be set up to clean automatically when the pressure differential across the media is too large or set at a predetermined time to flush. A pressure differential switch in combination with a flushing controller is a common approach for automation of filter cleaning.

## For Effluent Water Application

### Filtration Area

The filtration area is increased in order to properly filter the extremely poor water quality. By adding more tanks and filter area, the flow per tank is reduced allowing the filters more time to clean. Flow recommendations per 48-inch sand media tank, are in the range of 120-150 GPM rather than 200-300 range with good water quality.

### Flushing Valves

Filters flush automatically either by pressure differential or by a set time interval. In order to open a specific flush valve an electric signal is sent to a solenoid on the flush valve that opens a small orifice letting water into the bonnet on the valve. This forces the valve from an open operation position to a closed flushing position. The orifices in the solenoid valve are very small requiring 120 mesh filtration. Therefore, we avoid using a Command Filter for the effluent water, to operate the solenoid valves. We instead use a small air compressor in-order-to flush all valves pneumatically.

### Media Sample Collection

Always collect a sample of the new media used, sand in this case, in order to compare in the future with worn sand in the tanks. Silica sand filters the water very effectively, due to its sharp irregular angles. However, as water and particulate flow through the sand, the angular nature starts to wear, reducing filtration efficacy over time. Sand should be replaced every 3-5 years, potentially more often with effluent water's high particulate load.





## NMC-Pro Controller

The NMC Pro System Manager does more than open and close irrigation valves – it integrates all of your control features in one easy-to-use unit. Operate, monitor, and maximize the performance of your irrigation system from one central location.

### Features & Benefits

- **Irrigation Programs**  
Repeat and modify your irrigation schedules as needed – with up to 60 valve run time programs using time or volume-based scheduling
- **Irrigation Trigger Programs**  
Up to 15 external condition programs with programmable parameters for triggering irrigation events
- **Pump Control Programs**  
Control multiple pumps, delay start or shut down times between pumps and valves
- **Filter Flushing Programs**  
Schedules backflush programs eliminating the need for additional external backflush controllers
- **Nutrient and Chemical Injection Programs**  
A range of dosing options are available – by time, quantity or proportional along with detailed alarm messages
- **Alarm Programs**  
A range of alarms protects the system by isolating the problem and providing event details

NOTE: Dealers must be trained and authorized to purchase Digital Farming Products. Please contact your Netafim USA Dealer Relationship Manager for more information.



Fertikit 3G

## EC/pH Monitoring and Control Unit

The EC/pH 4G unit displays and transmits to an NMC Controller allowing chemical injection to regulate EC and pH levels. The self-contained dual EC/pH transmitter has a menu driven calibration procedure and error reporting. pH control helps prevent plugging and chemical precipitation and EC monitoring can be useful in controlling specific concentrations of fertilizers.

### Benefits Of The Upgraded Ec/Ph 4g Include:

- Easy to operate with sensor calibration
- Improved performance and sensor connections
- Two mounting options: panel or wall mount



## EC and pH Sensors

The electrodes of the JUMO EcoLine series are high-quality measurement sensors which provide a great price-performance ratio. JUMO EcoLine electrodes are manufactured with the JUMO U glass, which has proven itself for many years. A sturdy platinum cone ensures reliable measuring values for redox measurement. High viscous, acrylamide-free JUMO gel is used in both the glass and the PEI plastic shaft version. This gel is perfectly suitable for measurement in aqueous media. For high flow rates, the reference electrolyte can be equipped with an optional “salt charging” to increase the service life. JUMO EcoLine electrodes in the glass version are equipped with a ceramic diaphragm. A glass fiber diaphragm is used in the PEI plastic version.

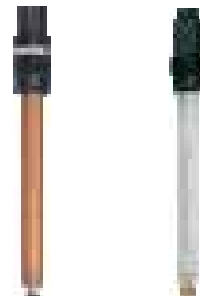

## NMC Pro: Dosing And EC Pre-Control For Synthetic Fertilizers And Chemicals

The NMC Pro controls fertilizer and chemical injection and monitors and controls EC and pH levels. When combined with a compact unit such as a Fertikit 3G you gain the ability to control and make precise injection and dosing application.

NMC-Pro includes 10 predefined dosing programs. Each program consists of injection methods, quantities and EC/pH target values. Each channel is completely independent and can be set to give a different amount. Overlapping between the various channels is possible.



**NMC PRO CONTROLLER**



## FERTIKIT 3G

- 3-5 proportional dosing channels
- Precision injection based on time, quantity, EC (in this application) and pH sensors or proportional to water flow for optimum system performance
- EC and pH programs do not have to use the same program parameters. As an example, fertilizers can be programmed to inject based on time or quantity while acid is programmed to inject based on proportion to water flow and pH set point
- Logs fertilizer meter flow rates and accumulates totals
- Logs and charts EC and pH levels
- Maintains consistent pH level in most irrigation water ensuring maximum availability of nutrients within the root zone (especially in sub-surface irrigation)

## EC and pH Monitoring and Control

EC and pH data are displayed and transmitted to the NMC Pro allowing chemical injection to regulate EC and pH levels. The self-contained dual EC/pH transmitter has a menu driven calibration procedure and error reporting.

- pH control helps prevent plugging and chemical precipitation
- EC monitoring can be useful in controlling specific concentrations of fertilizers

## Fertilizer and Chemical Injection Systems

Effluent water from dairies, swine or other processing facilities, is normally stored in lagoons and delivered to the drip irrigation system head control via a wet well on the edge of the lagoon. Nutrients contained in the effluent water are blended in the total flow of water and applied directly to the roots of the plant.

Fertilizer and chemical injection systems are incorporated into the design to apply line maintenance materials such as acid and liquid chlorine. The chemical injection system can also apply fertilizer, especially nitrogen, just in the rare case the nutrient-rich effluent water delivery system can't keep up.

[Please refer to the Corn Production Manual for procedures on Chlorine Injection and Acid Injection.](#)



*Download Corn  
Production  
Manual*





## Pressure Reducing Valves

Netafim Valves are manufactured from sturdy high-quality materials, in sizes from 3/4" to 24", to fit a wide variety of applications. Each valve is available with a choice of control functions and connections. Installation is easy and all Netafim valves offer reliable and dependable operation.

### Series 75 Valves

Strong and versatile, exhibiting exceptional hydraulic characteristics providing optimal control of irrigation systems.



## Manifolds

In a typical SDI system manifolds are used after the control valve to supply the driplines with water. Generally manifold material is PVC pipe with take offs to each dripline via the use of glue on saddles, drilled connections with grommets, or fittings that reduce the manifold size to the appropriate riser diameter. The riser diameter is dictated by the size of dripline being utilized in the system, and the total flowrate of the dripline. Riser, and manifold sizing are critical aspects of the overall uniformity of the system and are engineered to minimize the impact of friction loss within the irrigation block. Manifold friction losses need to be incorporated into the total desired uniformity of the system. Friction loss is a function of the total flow rate of the manifold vs. length, and inside diameter of the pipe being used. It is common to use pipe diameters that gradually reduce in size along the manifold as flow is reduced by each dripline connection. This is commonly referred to as "economic pipe sizing" and is perfectly acceptable as long as the system is designed to the required level of uniformity.

One critical aspect that needs to be considered in SDI-E is flushing the system to maintain cleanliness of the driplines. Often times manifolds need to be oversized to accommodate the much higher flow rates required during system flushing. This is an absolute necessity in an SDI-E system and should not be overlooked in the design process.

## Air/Vacuum Relief Vents

In any pressurized system entrapped air can be very problematic, but especially in a drip irrigation system. Because the pressures are so low a 10% reduction in flow can be disastrous. Any time water is pumped there is the potential for air to accumulate at high points along pipelines, at restrictions or turns in flow and at the ends of pipelines. The air tends to migrate to the high points in the system. If not removed, effective pipeline size can be restricted by this "air bubble" and can reduce overall flow and pressure to the dripline. When starting a drip irrigation system, air accumulates at the lower end of the pipeline and impedes filling. Adding air vents to all these locations will ensure long term system operation. It is just as important to allow air back into the system when the system is turned off. When the system is shut down, water continues to flow downhill in the drip laterals creating negative pressure in the drip lateral and at the emission point.

## Continuous Acting Combination Air/Vacuum Relief Vents

Used on the downstream of all freshwater pumps and upstream of all the field valves. Pumping water creates air that needs to be continuously removed. Continuous air vents are also installed at the highest points on pipelines and of the intake manifold of the filters.

For effluent water application a **Continuous Acting Combination Air/Vacuum Relief Vent** is recommended ahead of the booster pump because of the foaming nature and the high solid load in effluent water. This air vent should be installed in combination with an isolation valve installed underneath. This will allow for cleaning the air vent while the pump is still running.

**2" Combination Air Release/Vacuum Guard & Continuous Acting Air Vent**  
Releases air at pump priming and maintains the prime by not allowing air intake in long and/or undulating suction lines to pump stations.



## Dripline Specifications

After collecting a Drip Irrigation Suitability Test, analyzing source freshwater quality, as the first step in any design, the second step is choosing the proper dripline. This is where your Authorized Netafim Dealer, uses his local knowledge and experience to choose the appropriate dripline specifications for your farm.

### Emitter Spacing

Drip emitter spacing varies from 18 to 24 inches in the central states versus 12 to 18 inches in the San Joaquin Valley. This difference is generally due to soil texture differences where the central states have a finer soil texture than the coarser texture of the San Joaquin Valley. Moisture moves out further from the lateral in finer soils due to strong capillary forces, therefore a wider emitter spacing versus gravity taking over in coarse soils requiring a shorter spacing. Engineering also plays a minor role in determining the emitter spacing, where minor adjustments to the emitter spacing improve distribution uniformity without jeopardizing plant growth.

### Emitter Flow

Drip emitter flows range from 0.10 GPH to 0.42 GPH, in row crop production, but most applications use 0.16 GPH to 0.26 GPH, flow rates.

### Burial Depth

70% to 75% of plant roots grow in the top two feet, therefore there is no reason to go deeper than 14 inches with drip laterals. Unless there is an impediment to the downward movement of moisture by gravity, it is very difficult if not impossible to support 70% of your roots from a dripline placement deeper than 14 inches. 8 inch depth would be the best placement, to accommodate all the roots and even possibly germinate the crop seed. However, we have ground preparation, planting and harvest operations to accommodate. No more than a 14-inch depth for SDI is recommended.

## Flush Manifolds

Most permanent SDI systems use flush or collection manifolds so that an entire zone can be flushed at the same time (See Basic System Layout, pg. 8). A Collection Manifold at the end of the field also improves system Distribution Uniformity a percent or two, by balancing out the flow and pressure of all laterals collected in the manifold.

The use of flush manifolds is required to properly flush the driplines and reduce the labor requirement at the same time. This would be especially true on systems applying any effluent water. An Example of this is about 25% of the particles in dairy effluent water will not be captured by 120 mesh filtration (120 mesh = 125 microns = 0.125 mm = 0.0049"). These fine particles will migrate and collect at the hydraulic low ends of the system and without it being removed, could cause dripper plugging. Flush manifold systems can easily be automated with Netafim Digital Farming components.



Your Authorized Netafim Digital Farming Dealer, versed in the local aspects of crops irrigation with SDI, will help determine what dripline is best.



Scan to find an Authorized Digital Farming Dealer or visit [www.netafimusa.com](http://www.netafimusa.com)

## ARIES THINWALL DRIPLINES

The durability of Aries Thinwall Driplines means enhanced and better performance for a longer length of time. And it fits the widest range of applications.



## Nutrigation™

Nutrigation™ is the application of liquid or dissolved water-soluble fertilizer through the irrigation system in a controlled and efficient manner. The best way to maximize the performance of the crop is to install a Nutrigation™ unit that will accurately inject nutrients into the water supply for uptake by the crop.

### Dosing and EC Pre-Control for Nutrient-Rich Effluent and Fresh Water Mixing - Programing

The NMC Pro Controller controls the opening and closing of the Envalve Mixing Valve (EMV) located on the dairy effluent inlet pipe. Fresh and effluent water booster pumps deliver metered waters to the EMV, under approximately 40 pounds of pressure. The NMC regulates the mixture by sensing the Electrical Conductivity (EC) of the blended water and adjusting, opening or closing of the EMV. A Target EC Set Point is established within the DOSING Program (please review programing Target EC Pre-Control below). The higher the target the higher the ratio of effluent water to fresh water.

- Program – Select a program by entering the program number and confirm by pressing ENTER.
- EC Pre-control:
  - On – EC Pre-Control is active for this Dosing program
  - Off – EC Pre-Control is not active for this Dosing program; the EC Pre-Control valve will be shifted towards the fresh water source
- Target EC Pre-Control – Set the required EC Target Value, only visible if EC Pre-Control or EC alarms are active
- Calibration
- EC Pre-Control Runtime – Set the time it takes for the EC Pre-Control valve to shift from fully closed to fully open. This parameter is very important and must be exact as the controller uses this parameter to calculate the opening percentage of the EC Pre-Control Valve.
- EC Pre-Control Control Cycle – Set the time it takes since the EC Pre-Control valve changes position until the change is measured by the EC Pre-Control Sensor
- Coarse Tuning – Coarse Tuning is used to adjust control speed and strength. A higher value will result in faster correction but might lead to over-closing, a lower value might result in slow reaction
- Fine Tuning – used to fine tune EC Pre-Control behavior

On SDI-E systems extremely high solid loads are normal. Prior to utilizing the effluent blend, pre filtration is required to minimize the solids prior to pumping and final filtration.





## Dairy Manure Nutrient Content Strategy

As stated by UC Davis, et al in Dairy Manure Nutrient Content and Forms, Page 19 a manure strategy that is based on nitrogen content, does not give the farm the maximum value of manure phosphorus, due to the N:P ratio of a manure application strategy and crop consumption. Therefore, if the focus is on phosphorus levels in the soil, we need to make up the difference with commercial fertilizer. Including Netafim Ferti-kit 3G platform will allow for commercial nitrogen applications as well as system maintenance materials, such as acid and chlorine. Note however that because of nitrogen contribution in irrigation water and soil, commercial nitrogen may not always be needed. It is therefore best to partner with your agronomist to develop a nutrient budgeting plan.



Excerpts from Dairy Manure Nutrient Content and Forms, Manure Technical Guide Series, University of California Cooperative Extension.

When applying nutrient rich manure water, frequent sampling and analysis is recommended due to variations in digestible protein, fiber content, animal type, age and size, manure handling systems, bedding material, milk house and parlor waste and as a result varying solid, liquid and nutrient levels coming out of the barns. In California, quarterly reporting of nutrient applications to cropland, is required by the Central Valley Regional Water Quality Control Board.

The American Society of Biological and Agricultural Engineers developed a procedure to estimate the nutrients excreted by an animal, namely [ASAE Standard D384.2, ASABE 2005](#). This procedure bases estimates of N and P excretion of lactating cows on the level of milk production. An example using this procedure show the hypothetical results in Tables QQ and RR. This is an improvement over earlier calculations based on animal weight. The Central Valley Regional Water Quality Control Board is using this procedure to study the environmental impacts when planning a new dairy.

Applications of nutrient rich manure water through Subsurface Drip Irrigation Systems, ensures high distribution uniformity of water and nutrients to the crop, saving the farm money and environmental impacts. However, we need to change from an Nitrogen (N) focused nutrient strategy to a Phosphorus (P) focused strategy in order to take further advantage of the economic value.

UC Davis, et al say “Dairy Manure is relatively rich in P, and when used as the sole fertilizer nutrient source and applied at an appropriate rate based on its N content, inevitably P will accumulate in the soil. To capture more of the economic value of manure phosphorus as a nutrient source, farmers should apply manure at a rate closer to the amount required for crop P nutrition and make up the N shortage with commercial N fertilizer.”

Table QQ: Hypothetical amounts of manure N and P produced by a mature Holstein cow and associated replacement stock.<sup>1</sup>

Annual Milk Production (lb/Cow)	Manure N, lb/Year			Manure P, lb P <sub>2</sub> O <sub>5</sub> /Year		
	Milk Cow	Associated Replacement Stock	Total	Milk Cow	Associated Replacement Stock	Total
20,000	305	56	361	54	9	63
25,000	326	56	382	54	9	63

Table RR: Dairy Manure vs. Harvested Forage N:P Ratios.<sup>1</sup>

Annual Milk Production (lb/Cow)	Annual Manure N. lb/Cow	Annual Manure P. lb P <sub>2</sub> O <sub>5</sub> /Cow	N: P <sub>2</sub> O <sub>5</sub>
20,000	361	361	2.5
25,000	382	382	2.7

After 30% N loss by NH<sub>3</sub> volatilization

20,000	361	361	2.5
25,000	382	382	2.7

Typical N: P<sub>2</sub>O<sub>5</sub> ratio of harvested material

Various Legumes	2.3 - 3.0
Alfalfa	4.9

1. N and P manure totals for mature (milk and dry) cows are from Table QQ; and include amounts excreted by associated replacement animals.
2. P = P<sub>2</sub>O<sub>5</sub>/2,29
3. Forage N:P from Pettygrove 2009

In both Table XX and Table YY, studies revealed the huge variations in characteristics of lagoon water and lagoon water prior to diluting with fresh water on actual dairies in California's Central Valley. The tables show the need for regular sampling and analysis of the mixed water going to the crop, to ensure that proper nutrition levels are being applied to meet the crop needs without over application. For the full report visit [www.manure.ucdavis.edu](http://www.manure.ucdavis.edu).

**Table XX:** Physical and chemical characteristics for lagoon water collected from seven San Joaquin dairies in 2006-2008<sup>1</sup>

DAIRY #	=	9	3	10	11	12	8	13	Mean
pH		7.6	7.9	7.5	7.3	8.2	7.28.2	7.2	7.7
EC (dS/cm)		1-.9	4.2	7.8	7.8	5.7	6.9	0.0	6.2
TS (g/L)		10.2	4.2	7.7	6.1	4.0	5.8	22.9	8.5
TSS (g/L)		3.4	0.8	2.8	1.6	0.7	2.2	21.1	4.7
TKN (mg N/L)		1010	320	770	730	410	630	810	670
NH4-N (mg N/L)		600	200	440	480	270	360	170	360
Dissolved Org N (mg N/L)		150	20	120	90	60	120	50	90
TSS-N (mg N/L)		230	70	180	120	50	140	580	200
Total C (mg C/L) <sup>1</sup>		3580	1080	2660	2250	1200	1950	8430	3020
Dissolve Org C (mg C/L)		540	160	290	430	220	270	250	310
TSS-C (mg C/L)		1820	440	1340	900	390	950	76530	1920
Total C:TKN		3.5	3.4	3.5	3.1	2.9	3.1	10.4	4.5
Total C:Org N		8.8	9.1	8.2	9.1	8.9	7.0	13.1	9.8
TSS-C:TSS N		8.0	6.0	7.3	7.5	7.1	6.7	13.2	8.0
TSS <28 um and > 0.3um (%)		87	98	82	94	100	98	43	86

<sup>1</sup>Total C = Total suspended solid C + dissolved organic C + dissolved inorganic C

**Table YY:** Lagoon water characteristics at Central Valley dairies prior to dilution with fresh irrigation water. Samples taken from March 2000 through August 2002.

DAIRY	DAIRY	TOTAL N	NH4-N	P +	K	TOTAL SOLIDS (%)	pH	EC
Dairy 1	Median Range	645 424-1200	434 260-540	141 53-290	846 480-1040	1.1 0.04-2.5	7.1 7.01-7.4	7.5 4.5-9.5
Dairy 2	Median Range	284 171-1633	185 109-268	64 30-263	323 168-379	nes nes	7.3 7.0-7.6	2.2 2.1-3.4
Dairy 5	Median Range	353 110-637	202 70-320	80 28-254	429 169-722	0.5 0.2-2.5	7.3 6.8-7.5	4.1 2.1-5.7
Dairy 6	Median Range	164 51-332	124 10-203	43 9-63	213 35-408	0.2 0.1-0.8	7.2 6.8-7.8	2.6 0.7-4.2
Dairy 7	Median Range	397 222-513	321 168-433	75 43-122	521 282-705	0.4 0.3-0.6	7.2 6.8-7.5	5.0 3.1-6.4
Dairy 82	Median Range	325 240-345	258 220-267	52 45-58	652 486-773	nes nes	7.0 6.6-8.0	4.7 4.2-5.5
Dairy 9	Median Range	214 36-390	175 27-229	48 10-86	245 37-470	0.3 0.1-0.9	7.2 6.7-7.6	3.7 1.1-5.1
Dairy 10	Median Range	391 198-2420	272 158-370	70 26-380	602 280-880	0.4 0.2-2.0	7.2 6.9-7.5	4.9 3.0-6.1
Dairy 11	Median Range	468 249-953	334 135-554	79 39-283	640 258-992	0.8 0.3-2.0	7.3 6.8-8.1	6.9 3.6-9.6
All Dairy	Median Range	360 36-2420	256 10-540	72 9-380	496 35-1040	0.52 0.1-2.5	7.2 6.6-8.1	4.62 0.7-9.6



## Enhanced Sampling Program

Correlating Nitrogen applications with Electrical Conductivity levels requires enhanced effluent water sampling events along with standard tissue and soil sampling. In order to address the extreme variability in nutrient content of dairy effluent, a more robust sampling program is required in order to stay within BMP and to more accurately calibrate nutrient application; especially in the first year of operation” Sampling frequency and timing can later be reduced based on agronomist recommendations. The SDI-E system uses a sensor to monitor and regulate the EC of the blend of manure effluent and freshwater so that it stays under a target EC. The system maintains the EC by automatically adjusting a butterfly valve that increases or reduces the amount of manure effluent in the blend.

In order to adjust the system to meet a target blend ratio, the grower needs to determine what blend ratios will likely occur at different EC values. Since this will vary based on manure effluent characteristics, the grower first needs to run the system at different EC values and document a range of resulting blend ratios (e.g. “Based on prior experience, when the manure SDI system is set to a target EC of 1.5 dS/m, the blend is typically between X% and Y% manure effluent). With that knowledge, the grower can set the target EC as a way to control the blend ratio. These ranges can be further refined as the grower collects more data points from running the system over time.

Table ZZ shows an example of the sampling schedule for application of nutrient rich manure waters mixed with fresh water sources. Well water may in itself have nitrates levels that need to be added to the overall BMP for nitrogen application. Variations in the nutrient level being delivered to the subsurface drip Irrigation system, need sampling and verification of actual nutrients being applied.

**Table ZZ:** Sampling Schedule for Applying Nutrient Rich Manure Water Mix

Samples	JAN	FEB	MAR	APR	MAY	JUN	JUL	AUG	SEP	OCT	NOV	DEC
<b>Sample Frequency</b>												
Blend <sup>1</sup>	1	1	1	1	1	2	2	2	2	1	1	1
Effluent Intake <sup>1</sup>	1	1	1	1	1	2	2	2	2	1	1	1
Plant Tissue					1				1			
Fresh Water <sup>2</sup>						1						
Soil <sup>3</sup>				1						1		

<sup>1</sup> Lagoon and blend samples are taken twice per month during the first summer crop cycle in order to determine nutrient content and variability throughout the year. Sampling can then be reduced to monthly or less frequently depending on test variability and compliance requirements. Sampling is also needed to verify that the manure SDI filtration system is operating within acceptable limits for suspended solids. The monitoring program needs to remain flexible enough to adapt to ongoing changes within the lagoon and agronomic needs of the crop.

<sup>2</sup> An annual sample for each source of fresh water is recommended in order to estimate N contribution; the specific timing isn't important.

<sup>3</sup> Soil samples before planting of each crop are needed to calculate the available nitrogen for that crop, and after to estimate removal and N use efficiency.



Learn more  
from our  
partners:

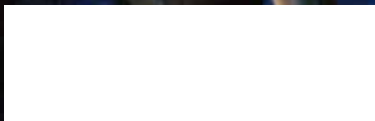

[www.suscon.org](http://www.suscon.org)

WUD

WESTERNUNITEDDAIRIES

[www.westernuniteddairies.com](http://www.westernuniteddairies.com)

## Maintenance Scheduling

Regularly scheduled maintenance is essential to the successful implementation of an SDI-E system. The table below is a recommended starting point for items in the system that routinely require attention from the operator of the system. This table is only a suggestion, and intervals can vary between operations as conditions in the system can change.

ITEM	DAILY	WEEKLY	BI-WEEKLY	MONTHLY	BI-MONTHLY	QUARTERLY	ANNUALLY
<b>Head Control Station</b>							
Check Filter Flushing	X						
Check Sand Level				X			
Calibrate EC and pH Sensors							X
Check Line Maintenance Material and Injection Rate	X						
Check Filter Maintenance Material and Injection Rate	X						
Check Mixing Valve Operation	X						
Check Flow Meter Operation		X					
Check Flow Rate of Pumps	X						
Check NMC Box for Moisture, Leaks, Cobwebs, etc.							X
Spot Check Collection Manifold Flush-outs for Dirty Water			X				
Time/Day Settings	X						
Power Flush Filters		X					
Back-up Your Program and Settings		X					
<b>Pipelines</b>							
Flush Driplines and Collection Manifolds			X				
Flush Mains and Submains				X			
Check Operation and Pressure of All PR Valves		X					
Check Q vs. P Field Valves for Clogging or Leaks		X					
<b>Driplines</b>							
Flushing with Fresh Water Only		X	X	Manure Water M, T, W, T, F. Fresh Water S, S.			
Line Maintenance Material During Fresh Water Runs		X					





[NETAFIMUSA.COM/EFFLUENT](https://NETAFIMUSA.COM/EFFLUENT)