

SANDSTORM™

SINGLE CHAMBER METAL MEDIA FILTER

HIGH QUALITY METAL MEDIA FOR ENHANCED SYSTEM LONGEVITY



30" AND 36" TANKS



48" TANK

APPLICATIONS

- Primary filter for water from open reservoirs and recycled water
- Filtration of water containing algae and other organic materials

SPECIFICATIONS

- Flow Range: 130 to 350 GPM
- Maximum Operating Pressure: 115 psi
- Minimum Backflush Pressure Required: 30 psi downstream of filter during backflush
- Backflushing Flow Rate: 88 to 190 GPM
- Access Port on Tank Dome and Sides Secured with Bolts:
8" for 30" Tank
10" for 36" and 48" Tanks
- Media Depth: 16"

PRODUCT ADVANTAGES

- Single chamber filter allows for efficient filtration and backflush uniformity.
- Large top and side access ports makes loading media and conducting maintenance easier.
- Two layer coating (phenolic and epoxy) for industry leading high corrosion and UV protection - for both the tanks and the manifolds.
- Injection molded PVC underdrain system with mushrooms and slots provides cleaning across the entire sand media bed.
- Modular manifolds for simple and flexible assembly and expansion.
- Wide range of tank diameters and configurations to address all application needs.
- Maximum protection and reliability in harsh conditions.

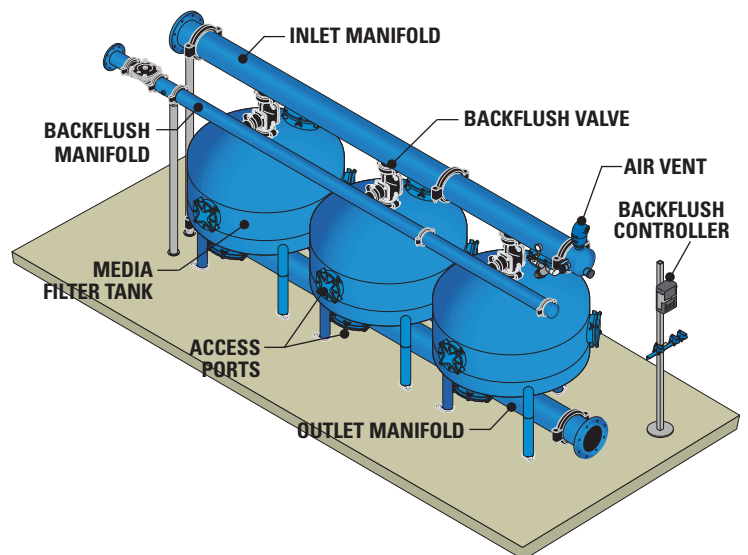

EFFICIENT FILTRATION

DESCRIPTION OF OPERATION

Water enters the filter via the inlet and spreads equally on the media. Dirt particles and organic materials are trapped in the media surface. The water that passes through and flows out via the filter elements will be free from dirt. The backflush cleaning process is done by shutting the inlet of the filter with the 3-way backflush valve and opening the drainage.

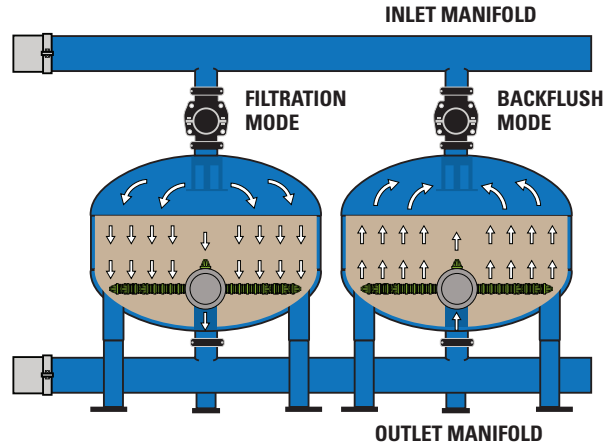

SPECIFICATIONS

TANK SIZE	FILTRATION AREA	MEDIA REQUIRED	TANK WEIGHT
30"	4.84 SQ. FT.	683 LBS.	264 LBS.
36"	7.00 SQ. FT.	1,047 LBS.	341 LBS.
48"	12.16 SQ. FT.	1,984 LBS.	519 LBS.

MEDIA REQUIRED refers to Crushed Silica Sand

MAXIMUM FLOW (GPM)

FILTER SIZE	FLOW (GPM)
30"	130
36"	200
48"	350

TANK PORTS

- 1 Filling port
- 2 Side service port
- 3 Bottom service port

HEADLOSS (FLOW VS. PRESSURE)

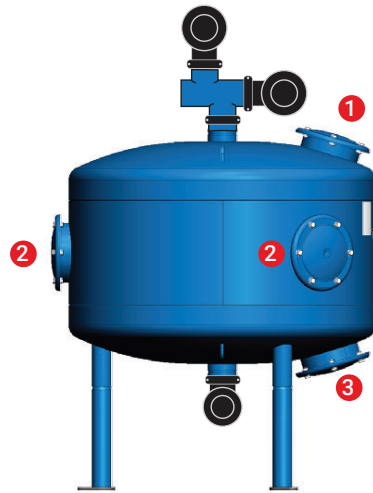
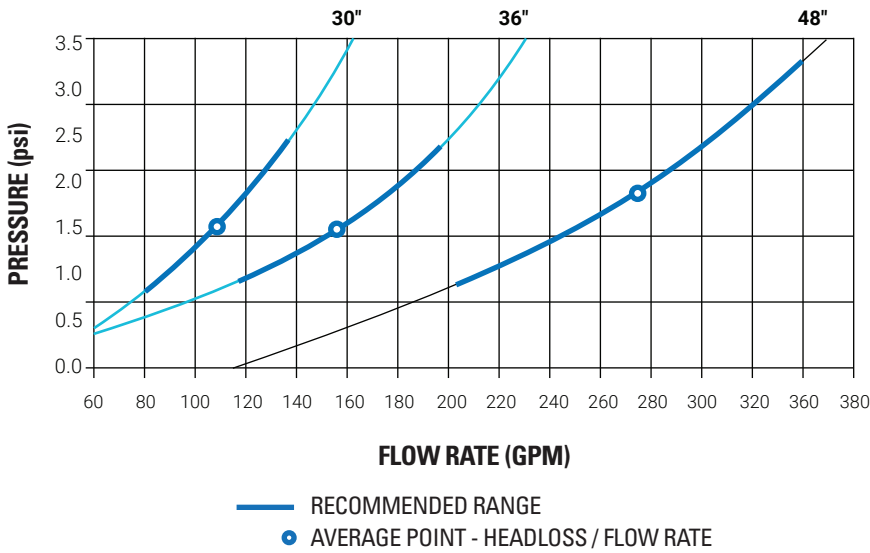

UNDERDRAIN SYSTEM

With injection molded PVC tubes and V slots

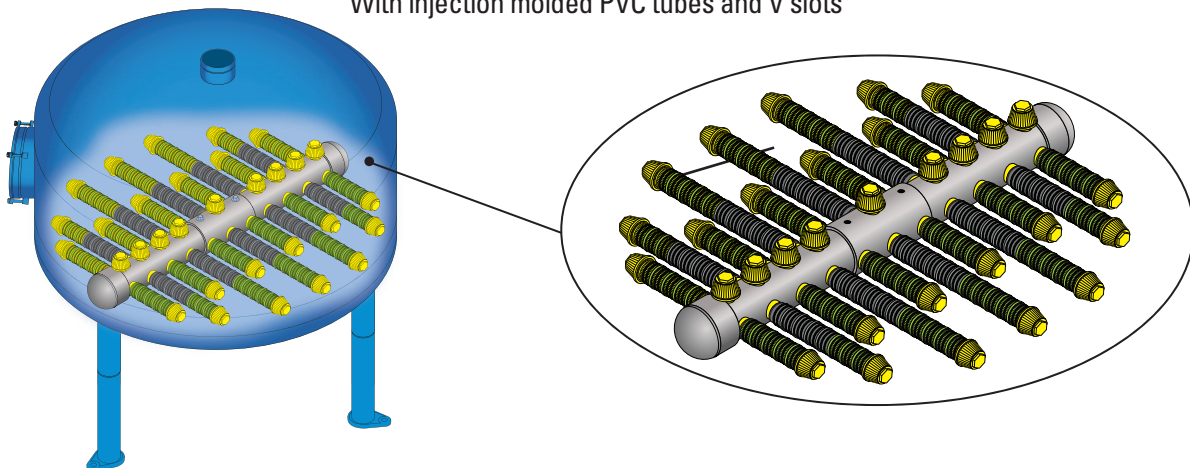

INSTALLATION CONFIGURATIONS

STRAIGHT END FEED INSTALLATION CONFIGURATIONS

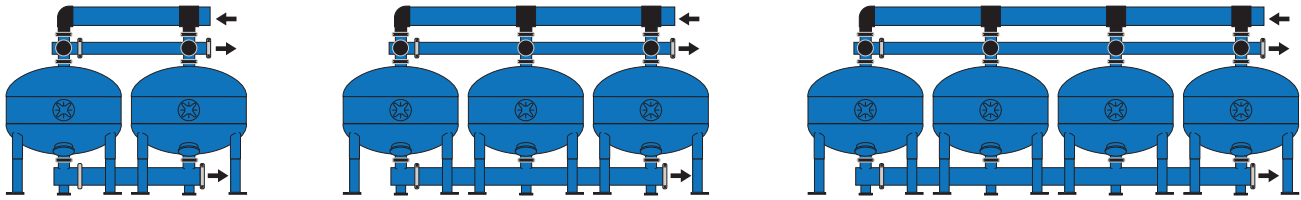

TEE CENTER FEED INSTALLATION CONFIGURATIONS

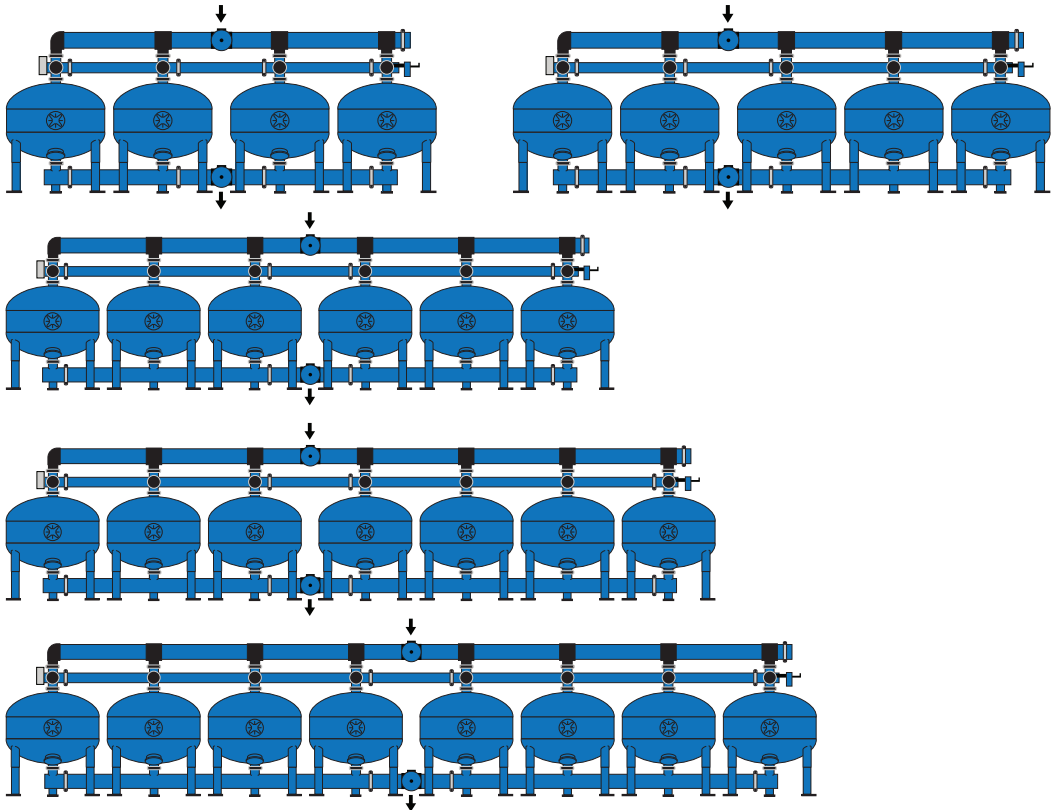

H PATTERN INSTALLATION CONFIGURATIONS

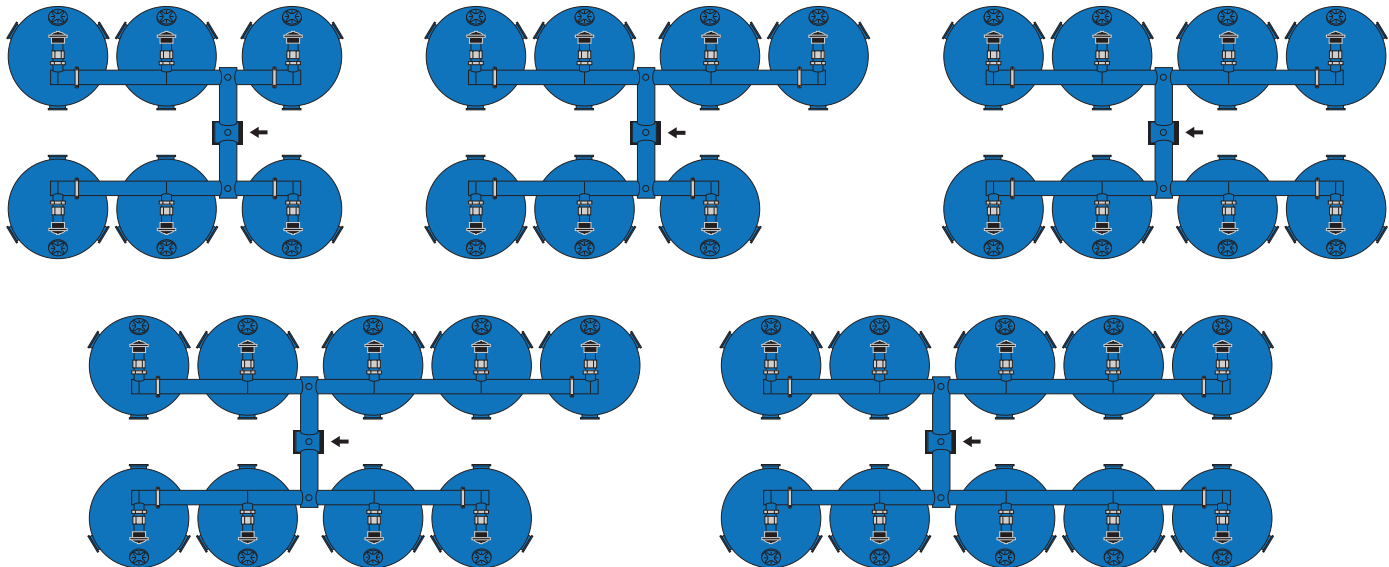

TECHNICAL & ORDERING INFORMATION

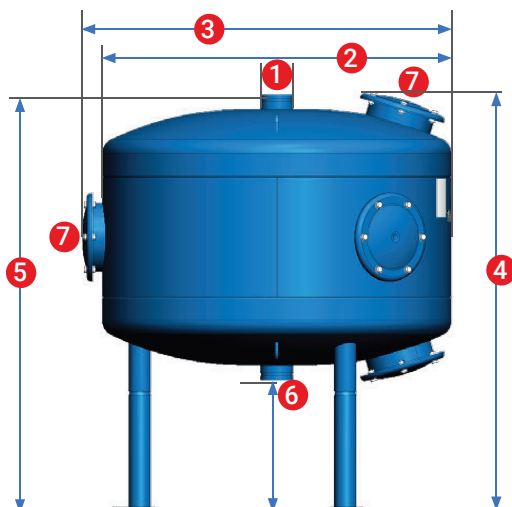

DIMENSIONS

KEY	DESCRIPTION	30" TANK	36" TANK	48" TANK
1	INLET PORT	3"	3"	4"
2	TANK DIAMETER	30"	36"	48"
3	TANK LENGTH	32.30"	40.7"	49.9"
4	OVERALL TANK HEIGHT	55"	55.7"	54.8"
5	TANK HEIGHT TO INLET PORT	54"	54"	55.43"
6	TANK HEIGHT TO OUTLET PORT	16"	16"	17.44"
7	ACCESS PORTS DIAMETER	8"	10"	10"

ORDERING INFORMATION

MODEL NUMBER	# FILTERS/SIZE	CONFIGURATION
2SMFSBS3002AAC	2 - 30"	STRAIGHT
2SMFSBS3602AAC	2 - 36"	STRAIGHT
2SMFSBS4802AAC	2 - 48"	STRAIGHT
2SMFSBS3003AAC	3 - 30"	STRAIGHT
2SMFSBS3603AAC	3 - 36"	STRAIGHT
2SMFSBS4803AAC	3 - 48"	STRAIGHT
2SMFSBS3004AAC	4 - 30"	STRAIGHT
2SMFSBS3604AAC	4 - 36"	STRAIGHT
2SMFSBS4804AAC	4 - 48"	STRAIGHT
2SMFSBT4804AAC	4 - 48"	TEE
2SMFSBS4805AAC	5 - 48"	STRAIGHT
2SMFSBT4805AAC	5 - 48"	TEE
2SMFSBT4806AAC	6 - 48"	TEE
2SMFSBH4806AAC	6 - 48"	H
2SMFSBT4807AAC	7 - 48"	TEE
2SMFSBH4807AAC	7 - 48"	H
2SMFSBT4808AAC	8 - 48"	TEE
2SMFSBH4808AAC	8 - 48"	H
2SMFSBT4810AAC	10 - 48"	TEE
2SMFSBH4810AAC	10 - 48"	H

ORDERING - TANK ONLY

MODEL NUMBER	SIZE
2SMFSB30	30"
2SMFSB36	36"
2SMFSB48	48"



NETAFIM USA
 5470 E. HOME AVE.
 FRESNO, CA 93727
 CS 888 638 2346
www.netafimusa.com