

DRIPPERLINES, DRIPPERS & OTHER EMITTERS

PRODUCT CATALOG

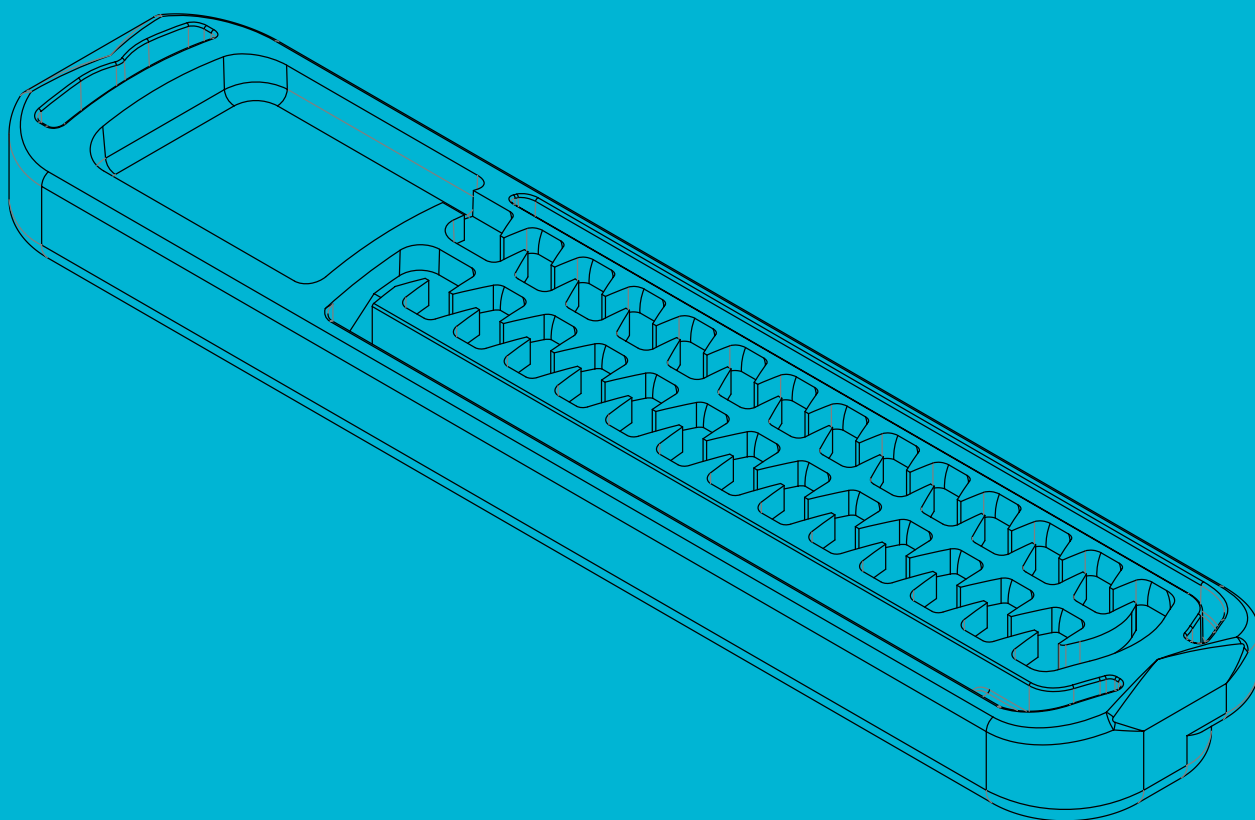

2018.V2

Products appearing in this catalogue may be covered by one or more of the following US Patent Nos. 6027048, 6206305 and other U.S. patents pending or corresponding issued or pending foreign patents

All rights are reserved. You are specifically prohibited and not allowed to reproduce, copy, duplicate, manufacture, supply, sell, hire, distribute or adapt all or any part of this publication including any packaging. Netafim™, are trademarks of Netafim™ Ltd., registered in the U.S. and other countries. We endeavor to provide accurate, quality and detailed information. However we cannot accept liability for your reliance on the provided information and you are advised to independently seek professional advice from Netafim™ and/or its authorized representatives. There is no undertaking by us that the provided information or any part thereof is accurate, complete or up to date .

Mention of third-party products is for informational purposes only and constitutes neither an endorsement nor a recommendation.

Netafim™ assumes no responsibility with regard to the performance or use of these products.

In no event shall Netafim™ be liable for any indirect, incidental, special or consequential damages.

CONTENTS

Introduction	4	
Technical terms	7	
UniRam™ AS	16009 - 16010 - 16012 - 17012 - 20010 - 20012 - 23010	8
UniRam™ CNL	16009 - 16010 - 16012 - 17012 - 20010 - 20012 - 23010	14
UniRam™ HCNL	16009 - 16010 - 16012 - 17012 - 20010 - 20012 - 23010	20
UniRam™ RC	16009 - 16010 - 16012 - 17012 - 20010 - 20012 - 23010	26
UniWine™ AS	16010 - 16012 - 17012 - 20010 - 20012	32
UniWine™ RC	16010 - 16012 - 20010 - 20012	38
UniRam™ AS XR	16010 - 16012 - 20010 - 20012 - 23010	40
UniGray™ CNL & HCNL	16009 - 16010 - 16012 - 17012 - 20010 - 20012	44
DripNet PC™ TWD & MWD	12125 - 12150 - 12200 - 12250 - 16125 - 16150 - 16200 - 16250 22135 - 22150 - 22250 - 25135 - 25150 - 25250	50
DripNet PC™ ASTWD & MWD	12125 - 12150 - 12200 - 12250 - 16125 - 16150 - 16200 - 16250 22135 - 22150 - 22250 - 25135 - 25150 - 25250	57
DripNet PC™ HWD	12009 - 12010 - 16009 - 16010 - 16012 - 20010 - 20012 - 23009	66
DripNet PC™ AS HWD	12009 - 12010 - 16009 - 16010 - 16012 - 20010 - 20012 - 23009	72
Aries™ HWD	12010 - 16009 - 16010 - 16012 - 20010 - 20012 - 23009	78
Aries™ MWD	16200 - 16250 - 16007 - 16008 - 22200 - 22250 - 25200	84
Aries™ TWD	16125 - 16150 - 22125 - 22135 - 22150	90
Typhoon Plus™	12125 - 12150 - 16080 - 16100 - 16125 - 16150 - 16180 - 22080 - 22125 22135 - 22150 - 22180 - 25125 - 25135 - 25150	94
Streamline Plus™	12060 - 12080 - 16055 - 16060 - 16080 - 22060 - 22070 - 22080	108
Microdrip		114
PC dripper PC, PC-LCNL, PC-HCNL		116
PCJ dripper PCJ, PCJ-LCNL, PCJ-HCNL		120
PCJ - HF On-line Bubblers		126
Button & Pot dripper		130
Arrow dripper		134
CapiNet™		136
Spiders		138
Assembled dripperlines		144
Netafim™ blank dripperlines		146
UniTechline™ AS		148
Techline™ CV		152
Bioline™ AS		154
TechNet™		158
TechNet™ AS		162
Landline™ 12 and 16		166
Landline™ 8		168
Techflow™ Junior		170
Leach Line A™		172

INTRODUCTION

Netafim drippers and dripperlines portfolio – how to select the right product for your application

Netafim offers a comprehensive portfolio of drippers (on line) and dripperlines (integral) that covers a wide range of crops and applications.

Our drip portfolio is divided into two main categories, Pressure Compensated drippers and dripperlines (PC), and Non Pressure Compensated drippers and dripperlines (NPC).

Each main dripperline category is further divided into three sub-categories covering different uses or applications. The sub-categories are Thin Wall Dripperlines (TWD), Medium Wall Dripperlines (MWD), and Heavy Wall Dripperlines (HWD).

- Heavy wall dripperlines include dripperlines with wall thickness of 0.9 mm or thicker.
- Medium wall dripperlines include dripperlines with wall thickness between 0.50 mm and 0.89 mm (included).
- Thin wall dripperlines include dripperlines with wall-thickness of 0.45 mm (included) or thinner.

The Pressure Compensated drippers and dripperlines can also include one or more of the following important features:

- Anti-Siphon mechanism (AS)
- Anti-Drain mechanism (CNL)
- Anti- Drain mechanism; high shut-off pressure (HCNL)
- Anti-Siphon with eXtra Root Resistance (AS XR)

AS: Anti-Siphon mechanism blocks contaminants from being drawn into the dripper from outside, makes it a critical addition to dripperlines installed below the surface, i.e. sub surface drip irrigation (SDI).

CNL: also called Anti-Drain, is an anti Drainage mechanism. When the pressure in the pipes drops (after valves shut-off at the end of an irrigation cycle) and the desired pressure is achieved, the CNL mechanism closes the water passage, hence pipes remain full of water and are ready for the next cycle, this makes it ideal for pulse irrigation (irrigation in short frequent cycles) in greenhouses, nurseries, and fruit trees.

HCNL: also called High Level Anti-Drain, is anti-drainage mechanism, similar to the CNL, but with higher shut-off pressure. This mechanism provides two main benefits:

1. Allows installation of non-leakage systems in areas with steeper slopes, thereby improving system efficiency, and reducing the number of DNL's (Dripperline Non-Leakage Valves).
2. Enables maintaining a higher pressure within the dripperlines used in pulse irrigation, hence allowing mixing and circulating water and nutrients in the system prior to an irrigation event. This makes it ideal for pulse irrigation (irrigation in short frequent cycles) in greenhouses, nurseries, and fruit trees.

AS XR (Anti-Siphon with eXtra Root Resistance): reduces significantly the risk of roots penetrating and clogging the drippers by incorporating copper oxide that inhibit root growth within the dripper. This innovative resin is mixed in the dripper cover to offers long lasting effect throughout the dripperline life. AS XR drippers are available in both UniRam™ and DripNet PC™. UniRam it also includes physical root barrier.

Netafim portfolio mapping:

ONLINE PC DRIPPERS	ONLINE NPC DRIPPERS	INTEGRAL PC DRIPPERLINES	INTEGRAL NPC DRIPPERLINES	OTHER DRIPPERS
<ul style="list-style-type: none"> ■ PC dripper ■ PCJ dripper 	<ul style="list-style-type: none"> ■ Button dripper ■ Pot dripper 	<ul style="list-style-type: none"> ■ UniRam ■ DripNet PC ■ Techline ■ TechNet 	<ul style="list-style-type: none"> ■ Aries ■ Typhoon Plus ■ Streamline Plus ■ Microdrip ■ Landline ■ Leach Line A 	<ul style="list-style-type: none"> ■ CapinNet ■ Arrow dripper

To select the right dripper, one needs to consider two variants: the crop, and the application it is intended to be used for. Other variants may apply which can narrow the selection and utilize additional features in Netafim portfolio. The following diagram assists in selecting the right dripperline or dripper for your application. Please note, this is only a generic guideline, for more specific guidelines please contact a Netafim expert in your region.

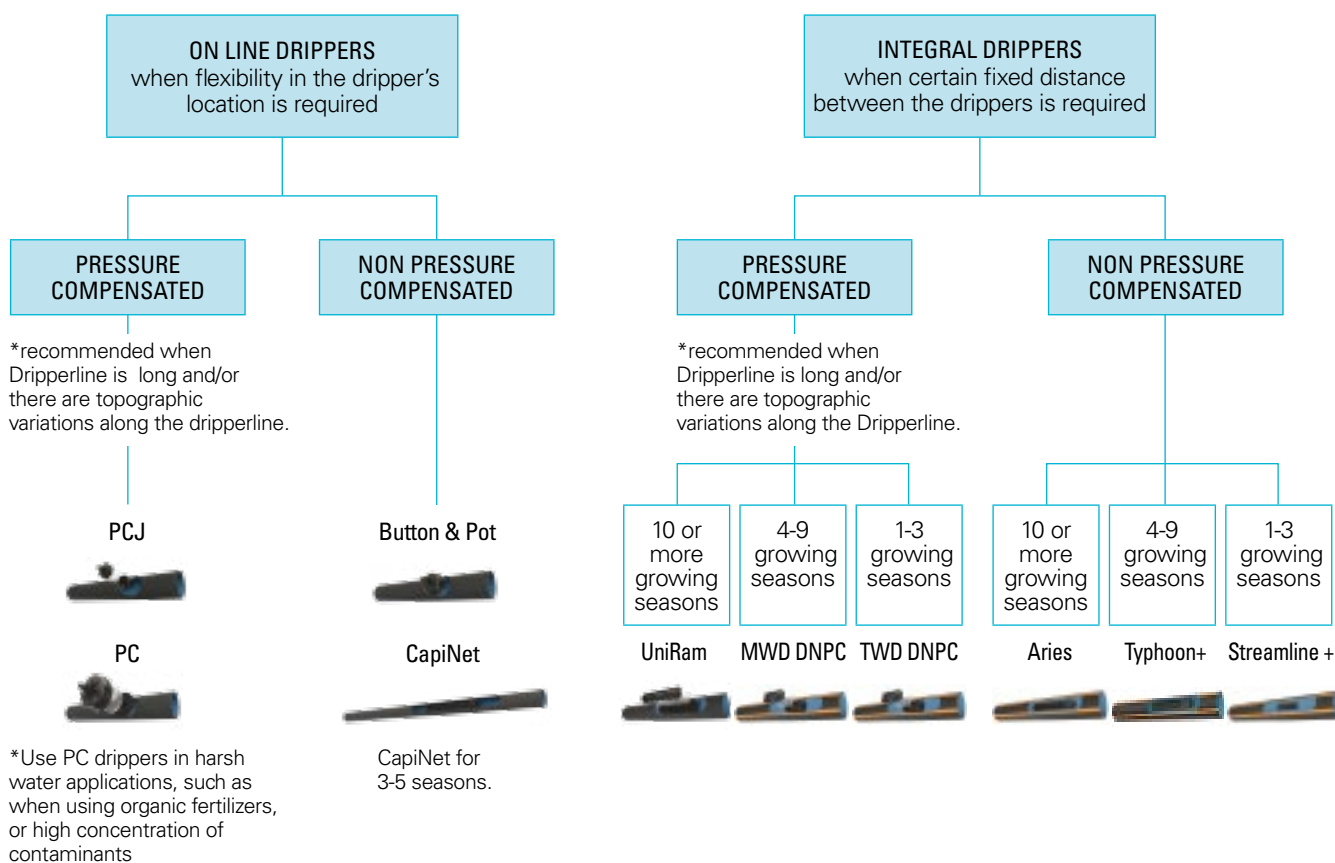

Additional features may also be considered when selecting your dripper or dripperline:

- When the dripperline is sub-surface installed, it is recommended to use AS in PC dripperlines, or Flap in Non PC dripperlines .
- In pulse irrigation especially in soilless media, it is recommended to use CNL dripperlines,
- If higher shut-off pressure for the dipper is required, or steep topography, HCNL dripperlines is recommended.
- If there is a risk for root penetration in sub-surfaced installed dripperlines the use of AS XR in PC dripperlines is recommended.

	AS	XR	CNL	HCNL
UniRam™	√	√	√	√
DripNet PC™	√	√	-	-
PCJ	√	-	√	√
PC	√	-	√	√

The following catalog is an aid material to enable to find basic data on each of the drip products at hands reach.

In each section you will find:

1. Main applications of the item displayed.
2. Features and benefits
3. Technical specifications
4. Technical data of drippers and dripperlines
5. A table of all active catalog numbers
6. Basic packaging data

Use of the catalog number tables

The tables display main data. For further information apply to a Netafim™ representative.

A Netafim™ catalog number consists of the following elements:

- a) 5 consecutive digits indicating the material group
- b) 6 consecutive digits indicating a specific product within that material group.

To create a full catalog number, choose the relevant material group and add to it the 6 digits that define dripper flow rate and spacing (these instructions apply to the integral products).

For example:

UNIRAM™ AS 16010

Catalog number **13720** - (any of below 6 digits)

FLOW RATE (L/H)	DISTANCE BETWEEN DRIPPERS (M)													
	0.15	0.20	0.25	0.30	0.33	0.40	0.50	0.60	0.65	0.70	0.75	0.80	0.90	1.00
1.0		000400	000450	000500	000550	000600	000700	000800			000900	001000		001200
1.6		001520	001550	001600	001650	001700	001800	001900	001950		002000	002100	002200	002500
2.3		002600		002700	002750	002850	002900	003000	003100		003200	003000		003600
3.5		003950		004000	004100	004160	004200	004270		004350	004370	004440	004470	004500
Bundled coil length (m)	500	500	500	500	500	500	500	500	500	500	500	500	500	500

Missing catalog numbers available upon request.

Product : Uniram™ AS 16010 , 1.6 l/h , 0.40 m = 13720-001700

*In the same table additional information can be found:

- 1) Equipment will arrive on bundled coils
- 2) Length of dripperline on the coil: 500 m

As specified above, these are the active catalog numbers in our ERP systems. Additional numbers can be activated/ opened as required in each of the empty cells in the table.

As for the other products (on-line drippers, arrow drippers, etc.) the tables similarly display the relevant material group (first 5 digits) where the numbers in the tables (the other 6 digits) indicate the number of units supplied in each of the different packing options.

This catalog contains all the metric based information, does not include all the USA used catalog numbers.

TECHNICAL TERMS

International standards

Standard ISO 9261

The majority of drippers and dripperlines appearing in this catalog comply with the international standard ISO 9261. This standard refers to and deals with these products and actually determines their quality. The absolute majority of the Netafim™ irrigation products are in compliance with the International Standards provisions and under the supervision of the relevant institutions.

Standards 9001 and 14001

These standards deal with and focus on the organization/ operation/ adaptation of the manufacturing plant aimed at meeting the international regulations stated in these documents. Netafim™ complies with and possesses the relevant accredited certifications and as such meets those international standards.

Nominal flow rate

For a non-PC dripper:

Flow rate, expressed in liters per hour, of a dripper operating at the nominal test pressure: 1.0 bar, and at water temperature of 23°C +/- 3°C.

For a pressure compensated dripper: Flow rate, expressed in liters per hour, of a dripper operating within the range of regulation, and at water temperature of 23°C +/- 3°C.

Maximum working pressure

Highest water pressure recommended at the inlet to a dripper/ dripperline ensuring proper operation of the dripper/ dripperline.

Dripper exponent

The relation between the flow rate (Q) in liters per hour, and the inlet pressure (P) in meters column of water in a dripper, is given by the formula:

$$Q \text{ (l/h)} = K * P \text{ (meters)} ^ X$$

Where:

K is a specific constant to each dripper

X is the dripper exponent

Note: for an exponent of 0, the emission rate does not vary with pressure, for an exponent of 1 the emission rate varies linearly with pressure.

Pressure compensated dripper/dripperline

Dripper/ dripperline maintaining a constant flow rate at varying water pressures at the dripper/dripperline inlet within the specified pressure limits.

Anti drain dripper/ dripperline

A dripper/ dripperline with "zero" flow whenever the dripper/ dripperline's inlet pressure is lower than the value declared by the manufacturer (other than zero).

Recommended filtration level

Filtration level recommendations included in this catalog refer to situations where the TTS (Total Suspended Solids)/ sand/ organic matter content are standard for water used for agricultural applications. Whenever abnormal levels of TTS (Total Suspended Solids)/ sand/ organic matter are identified, it is recommended to consult the Netafim™ Technical Department.

Flushing pressure

The maximum pressure permitted for application via the irrigation system during the flushing process. These pressure rates are permitted for use provided the process does not exceed half hour of continuous flushing when the dripperlines are continually flushed (at least some of the dripperlines on the same system must be open during flushing).

Note: Flushing process is done when dripperline ends kept open.



UNIRAM™ AS

INTEGRAL PRESSURE-COMPENSATING, CONTINUOUSLY SELF-CLEANING, ANTI-SIPHON MECHANISM DRIPPER



16009 - 16010 - 16012 - 17012 - 20010 - 20012 - 23010

APPLICATIONS

- Deciduous and tree irrigation.
- Sub-surface multi seasonal row crops.

FEATURES AND BENEFITS

- Pressure compensated: Precise and equal amounts of water are delivered over a broad pressure range. 100% uniformity of water and nutrient distribution along the laterals.
- Anti-Siphon mechanism: Prevents contaminants from being drawn into the dripper, which is needed in sub surface applications.
- Continuously self flushing: Flushes debris as it is detected, throughout operation, not just at the beginning or end of a cycle, ensuring uninterrupted dripper operation.
- Self-flushing system with wide filtration area improves resistance to clogging thus making UniRam™ highly resistant when using low quality water, which leads in reduction in filtraion requirements, hence increasing filtration efficiency.
- Physical root barrier: Better protection against root intrusion without reliance on chemicals.
- TurboNet™ labyrinth assures wide water passages, large deep and wide cross section improves clogging resistance. which allows reducing the filtration requiremnts, and increasing flushing efficiency.

SPECIFICATIONS

- Pressure-compensating range: 0.5-4.0 bar.
- Anti-Siphon mechanism.
- Largest filter in each dripper. Recommended filtration: according to drippers flow rate. Filtration method is to be selected based on the kind and concentration of the dirt particles existing in the water. Wherever sand exceeding 2 ppm exists in the water, a Hydrocyclone is to be installed before the main filter. When sand/silt/clay solids exceed 100 ppm, pre treatment will be applied according to Netafim™ expert team's instructions.
- Double TurboNet™ labyrinth with large water passage.
- To be "welded" into thick-walled dripperlines (0.90, 1.00, 1.20 mm).
- Injected dripper, very low CV.
- Injected silicon diaphragm.
- High UV resistant. Resistant to standard nutrients used in agricultural.
- UniRam™ dripperlines, which is needed in sub surface applications. meet ISO 9261 Standards with production certified by the Israel Standards Institute (SII).

DRIPPERS TECHNICAL DATA

FLOW RATE* (L/H)	WORKING PRESSURE RANGE (BAR)	WATER PASSAGES DIMENSIONS WIDTH-DEPTH-LENGTH (MM)	FILTRATION AREA (MM²)	CONSTANT K	EXPONENT* X	RECOMMENDED FILTRATION (MICRON)/(MESH)
0.7	0.5 – 4.0	0.70 x 0.65 x 40	110	0.7	0	130/120
1.0	0.5 – 4.0	0.83 x 0.74 x 40	130	1.0	0	130/120
1.6	0.5 – 4.0	1.07 x 0.79 x 40	130	1.6	0	200/80
2.3	0.5 – 4.0	1.26 x 0.95 x 40	130	2.3	0	200/80
3.5	0.5 – 4.0	1.59 x 1.10 x 40	150	3.5	0	200/80

* Within working pressure range

UNIRAM™ AS 16009

Catalog number **13740** - (any of below 6 digits)

FLOW RATE (L/H)	DISTANCE BETWEEN DRIPPERS (M)													
	0.15	0.20	0.25	0.30	0.33	0.40	0.50	0.60	0.65	0.70	0.75	0.80	0.90	1.00
0.7														
1.0		001190		001200		001250	001400	001550	001570	001600				
1.6				002300		002400	002500	002600	002650	002700	002750	002800		
2.3		003350		003400		003690	003700	003800	003850	003870	003900	004000	004100	004200
3.5				009700		009750	010035	010040	010045	010050	010100	010150	010200	000001
Bundled coil length (m)	500	500	500	500	500	500	500	500	500	500	500	500	500	500

Missing catalog numbers available upon request.

DRIPPERLINES TECHNICAL DATA

MODEL	INSIDE DIAMETER (MM)	WALL THICKNESS (MM)	OUTSIDE DIAMETER (MM)	MAX. WORKING PRESSURE (BAR)	MAXIMUM FLUSHING PRESSURE (BAR)	KD
16009	14.20	0.90	16.00	3.0	3.9	1.30

DRIPPERLINES PACKAGE DATA (ON BUNDLED COILS)

MODEL	WALL THICKNESS (MM)	COIL LENGTH (M)	DISTANCE BETWEEN DRIPPERS (M)	AVERAGE* COIL WEIGHT (KG)	COILS IN A 40 FEET CONTAINER (UNITS)	TOTAL IN A 40 FEET CONTAINER (M)
16009	0.90	500	0.15 to 1.00	20.3	330	165000

*According to drippers spacing

UNIRAM™ AS 16010

Catalog number **13720** - (any of below 6 digits)

FLOW RATE (L/H)	DISTANCE BETWEEN DRIPPERS (M)													
	0.15	0.20	0.25	0.30	0.33	0.40	0.50	0.60	0.65	0.70	0.75	0.80	0.90	1.00
0.7		000180	000185	000200		000220	000240	000260			000280			000300
1.0	000380	000400	000450	000500	000550	000600	000700	000800	000840	000850	000900	001000	001030	001200
1.6	001450	001520	001550	001600	001650	001700	001800	001900	001950	001965	002000	002100	002200	002500
2.3		002600	002620	002700	002750	002850	002900	003000	003100	003150	003200	003300	003400	003600
3.5		003950		004000	004100	004160	004200	004270	004300	004350	004370	004440	004470	004500
Bundled coil length (m)	500	500	500	500	500	500	500	500	500	500	500	500	500	500

Missing catalog numbers available upon request.

DRIPPERLINES TECHNICAL DATA

MODEL	INSIDE DIAMETER (MM)	WALL THICKNESS (MM)	OUTSIDE DIAMETER (MM)	MAX. WORKING PRESSURE (BAR)	MAXIMUM FLUSHING PRESSURE (BAR)	KD
16010	14.20	1.00	16.20	3.5	4.6	1.30

DRIPPERLINES PACKAGE DATA (ON BUNDLED COILS)

MODEL	WALL THICKNESS (MM)	COIL LENGTH (M)	DISTANCE BETWEEN DRIPPERS (M)	AVERAGE* COIL WEIGHT (KG)	COILS IN A 40 FEET CONTAINER (UNITS)	TOTAL IN A 40 FEET CONTAINER (M)
16010	1.00	500	0.15 to 1.00	22.1	330	165000

*According to drippers spacing

UNIRAM™ AS 16012

Catalog number **13700** - (any of below 6 digits)

FLOW RATE (L/H)	DISTANCE BETWEEN DRIPPERS (M)													
	0.15	0.20	0.25	0.30	0.33	0.40	0.50	0.60	0.65	0.70	0.75	0.80	0.90	1.00
0.7				000100		000120								
1.0		000400	000450	000500			000600	000680			000700			000900
1.6		001000		001050	001087	001095	001100	001150			001200	001300		001400
2.3		001680		001700	001800	001900	002000	002050	002100	002200	002300	002350		002500
3.5				003200		003300	003400	003500		003550	003600	003700		004000
Bundled coil length (m)	400	400	400	400	400	400	400	400	400	400	400	400	400	400

Missing catalog numbers available upon request.

DRIPPERLINES TECHNICAL DATA

MODEL	INSIDE DIAMETER (MM)	WALL THICKNESS (MM)	OUTSIDE DIAMETER (MM)	MAX. WORKING PRESSURE (BAR)	MAXIMUM FLUSHING PRESSURE (BAR)	KD
16012	14.20	1.20	16.60	4.0	5.2	1.30

DRIPPERLINES PACKAGE DATA (ON BUNDLED COILS)

MODEL	WALL THICKNESS (MM)	COIL LENGTH (M)	DISTANCE BETWEEN DRIPPERS (M)	AVERAGE* COIL WEIGHT (KG)	COILS IN A 40 FEET CONTAINER (UNITS)	TOTAL IN A 40 FEET CONTAINER (M)
16012	1.20	400	0.15 to 1.00	21.2	352	140800

*According to drippers spacing

UNIRAM™ AS 17012

Catalog number **14000** - (any of below 6 digits)

FLOW RATE (L/H)	DISTANCE BETWEEN DRIPPERS (M)													
	0.15	0.20	0.25	0.30	0.33	0.40	0.50	0.60	0.65	0.70	0.75	0.80	0.90	1.00
0.7		000010		000020		000025								
1.0	000050	000070	000085	000100		000125	000150		000170	000190	000200	000210		000250
1.6	000600	000650	000700	000800	000830	000900	001000	001050		001110	001130	001135		001140
2.3		001200	001250	001400	001470	001550	001700	001900	001930	001950	002100	002130		002300
3.5				002380		002385	002390	002395		002399	002410	003000	003210	003600
Bundled coil length (m)	400	400	400	400	400	400	400	400	400	400	400	400	400	400

Missing catalog numbers available upon request.

DRIPPERLINES TECHNICAL DATA

MODEL	INSIDE DIAMETER (MM)	WALL THICKNESS (MM)	OUTSIDE DIAMETER (MM)	MAX. WORKING PRESSURE (BAR)	MAXIMUM FLUSHING PRESSURE (BAR)	KD
17012	14.60	1.20	1700	4.0	5.2	1.10

DRIPPERLINES PACKAGE DATA (ON BUNDLED COILS)

MODEL	WALL THICKNESS (MM)	COIL LENGTH (M)	DISTANCE BETWEEN DRIPPERS (M)	AVERAGE* COIL WEIGHT (KG)	COILS IN A 40 FEET CONTAINER (UNITS)	TOTAL IN A 40 FEET CONTAINER (M)
17012	1.20	400	0.15 to 1.00	22.4	352	140800

*According to drippers spacing

UNIRAM™ AS 20010

Catalog number **14520** - (any of below 6 digits)

FLOW RATE (L/H)	DISTANCE BETWEEN DRIPPERS (M)													
	0.15	0.20	0.25	0.30	0.33	0.40	0.50	0.60	0.65	0.70	0.75	0.80	0.90	1.00
0.7														
1.0				001000		001025	001050	001100			001200			001300
1.6				001800		001900	001950	002050		002065	002070	002100		002200
2.3				002400		002500	002550	002600		002650	002700	002800		003000
3.5				003500		003600	003700	003800		003850	003890	004000		004100
Bundled coil length (m)	300	300	300	300	300	300	300	300	300	300	300	300	300	300

Missing catalog numbers available upon request.

DRIPPERLINES TECHNICAL DATA

MODEL	INSIDE DIAMETER (MM)	WALL THICKNESS (MM)	OUTSIDE DIAMETER (MM)	MAX. WORKING PRESSURE (BAR)	MAXIMUM FLUSHING PRESSURE (BAR)	KD
20010	17.50	1.00	19.50	3.5	4.6	0.40

DRIPPERLINES PACKAGE DATA (ON BUNDLED COILS)

MODEL	WALL THICKNESS (MM)	COIL LENGTH (M)	DISTANCE BETWEEN DRIPPERS (M)	AVERAGE* COIL WEIGHT (KG)	COILS IN A 40 FEET CONTAINER (UNITS)	TOTAL IN A 40 FEET CONTAINER (M)
20010	1.00	300	0.15 to 1.00	17.4	330	99000

*According to drippers spacing

UNIRAM™ AS 20012

Catalog number **14500** - (any of below 6 digits)

FLOW RATE (L/H)	DISTANCE BETWEEN DRIPPERS (M)													
	0.15	0.20	0.25	0.30	0.33	0.40	0.50	0.60	0.65	0.70	0.75	0.80	0.90	1.00
0.7		000008	000009	007500		007600	007700	007800			007900			008000
1.0		000020	000040	000050	000065	000075	000080	000095		000096	000100	000104	000108	000110
1.6		000170	000200	000300	000360	000400	000600	000700		000800	000900	000960	000970	000980
2.3		000990	001020	001150	001310	001450	001550	001800	001850	001920	001950	002100	002300	002400
3.5				005300		005400	005700	005800		005900	006000	006100	006200	006700
Bundled coil length (m)	300	300	300	300	300	300	300	300	300	300	300	300	300	300

Missing catalog numbers available upon request.

DRIPPERLINES TECHNICAL DATA

MODEL	INSIDE DIAMETER (MM)	WALL THICKNESS (MM)	OUTSIDE DIAMETER (MM)	MAX. WORKING PRESSURE (BAR)	MAXIMUM FLUSHING PRESSURE (BAR)	KD
20012	17.50	1.20	19.90	4.0	5.2	0.40

DRIPPERLINES PACKAGE DATA (ON BUNDLED COILS)

MODEL	WALL THICKNESS (MM)	COIL LENGTH (M)	DISTANCE BETWEEN DRIPPERS (M)	AVERAGE* COIL WEIGHT (KG)	COILS IN A 40 FEET CONTAINER (UNITS)	TOTAL IN A 40 FEET CONTAINER (M)
20012	1.20	300	0.15 to 1.00	20.2	330	99000

*According to drippers spacing

UNIRAM™ AS 23010

Catalog number **14635** - (any of below 6 digits)

FLOW RATE (L/H)	DISTANCE BETWEEN DRIPPERS (M)													
	0.15	0.20	0.25	0.30	0.33	0.40	0.50	0.60	0.65	0.70	0.75	0.80	0.90	1.00
0.7				000500		000550	000600	000650			000700			000750
1.0				001300		001400	001500	001570	001600		001700			001850
1.6						002200	002300	002400	002470	002520	002600	002660		002900
2.3						003500	003600	003705	003740	003800	003900	003950	004050	004100
3.5						005000	005100	005200		005400	005500			005700
Carton coil length (m)	200	200	200	300	300	300	300	300	300	300	300	300	300	300

Missing catalog numbers available upon request.

DRIPPERLINES TECHNICAL DATA

MODEL	INSIDE DIAMETER (MM)	WALL THICKNESS (MM)	OUTSIDE DIAMETER (MM)	MAX. WORKING PRESSURE (BAR)	MAXIMUM FLUSHING PRESSURE (BAR)	KD
23010	20.80	1.00	22.80	3.0	3.5	0.30

DRIPPERLINES PACKAGE DATA (ON CARTON COILS)

MODEL	WALL THICKNESS (MM)	COIL LENGTH (M)	DISTANCE BETWEEN DRIPPERS (M)	AVERAGE* COIL WEIGHT (KG)	COILS IN A 40 FEET CONTAINER (UNITS)	TOTAL IN A 40 FEET CONTAINER (M)
23010	1.00	200	0.15 to 0.25	14.7	480	96000
		300	0.30 to 1.00	20.7		144000

*According to drippers spacing





UNIRAM™ CNL

INTEGRAL PRESSURE-COMPENSATING,
CONTINUOUSLY SELF-CLEANING, ANTI-SIPHON AND
ANTI-DRAIN MECHANISM DRIPPER



16009 - 16010 - 16012 - 17012 - 20010 - 20012 - 23010

APPLICATIONS

- Greenhouse, deciduous and tree irrigation.
- Sub-surface multi seasonal row crops.
- Precise irrigation, Multiple pulse Irrigation

FEATURES AND BENEFITS

- Pressure compensated: Precise and equal amounts of water are delivered over a broad pressure range. 100 % uniformity of water and nutrient distribution along the laterals.
- Anti-Siphon mechanism: Prevents contaminants from being drawn into the dripper, which is needed in sub surface applications.
- Anti-drain (CNL) system: Eliminates drainage and refill effect, and improves efficiency in pulse irrigation.
- Continuously self flushing: Continuously flushing debris, throughout operation, not just at the beginning or end of a cycle, ensuring uninterrupted dripper operation.
- Self-flushing system with wide filtration area improves resistance to clogging thus making UniRam™ highly resistant when using low quality water, which leads in reduction in filtration requirements, hence increasing filtration efficiency.
- Physical root barrier: Better protection against root intrusion without reliance on chemicals.
- TurboNet™ labyrinth assures wide water passages, large deep and wide cross section improves clogging resistance.

SPECIFICATIONS

- Pressure-compensating range: 1.0-4.0 bar.
- Anti-Siphon and Anti-Drain mechanism.
- Largest filter in each dripper. Recommended filtration: 130 micron / 120 mesh.
Filtration method is to be selected based on the kind and concentration of the dirt particles existing in the water. Wherever sand exceeding 2 ppm exists in the water, a Hydrocyclone is to be installed before the main filter. When sand/ silt/ clay solids exceed 100 ppm, pre treatment will be applied according to Netafim™ expert team's instructions.
- Double TurboNet™ labyrinth with large water passage.
- To be "welded" into thick-walled dripperlines (0.90, 1.00, 1.20 mm).
- Injected dripper, very low CV.
- Injected silicon diaphragm.
- High UV resistant. Resistant to standard nutrients used in agricultural.
- UniRam™ dripperlines meet ISO 9261 Standards with production certified by the Israel Standards Institute (SII).

DRIPPERS TECHNICAL DATA

FLOW RATE* (L/H)	WORKING PRESSURE RANGE (BAR)	WATER PASSAGES DIMENSIONS WIDTH-DEPTH-LENGTH (MM)	FILTRATION AREA (MM²)	CONSTANT K	EXPONENT* X	RECOMMENDED FILTRATION (MICRON)/(MESH)	SHUT OFF PRESSURE (BAR)
0.7	1.0 – 4.0	0.70 x 0.65 x 40	110	0.7	0	130/120	0.14
1.0	1.0 – 4.0	0.83 x 0.74 x 40	130	1.0	0	130/120	0.14
1.6	1.0 – 4.0	1.07 x 0.79 x 40	130	1.6	0	130/120	0.14
2.3	1.0 – 4.0	1.26 x 0.95 x 40	130	2.3	0	130/120	0.14
3.5	1.0 – 4.0	1.59 x 1.10 x 40	150	3.5	0	130/120	0.14

* Within working pressure range

UNIRAM™ CNL 16009

Catalog number **13920** - (any of below 6 digits)

FLOW RATE (L/H)	DISTANCE BETWEEN DRIPPERS (M)													
	0.15	0.20	0.25	0.30	0.33	0.40	0.50	0.60	0.65	0.70	0.75	0.80	0.90	1.00
0.7	000700													
1.0	001150	001200		001300		001400	001500	001700						
1.6	002100	002200		002300		002500	002600			002800				
2.3				003400		003580	003600				003900			
3.5						005000	005050							
Bundled coil length (m)	500	500	500	500	500	500	500	500	500	500	500	500	500	500

Missing catalog numbers available upon request.

DRIPPERLINES TECHNICAL DATA

MODEL	INSIDE DIAMETER (MM)	WALL THICKNESS (MM)	OUTSIDE DIAMETER (MM)	MAX. WORKING PRESSURE (BAR)	MAXIMUM FLUSHING PRESSURE (BAR)	KD
16009	14.20	0.90	16.00	3.0	3.9	1.30

DRIPPERLINES PACKAGE DATA (ON BUNDLED COILS)

MODEL	WALL THICKNESS (MM)	COIL LENGTH (M)	DISTANCE BETWEEN DRIPPERS (M)	AVERAGE* COIL WEIGHT (KG)	COILS IN A 40 FEET CONTAINER (UNITS)	TOTAL IN A 40 FEET CONTAINER (M)
16009	0.90	500	0.15 to 1.00	20.3	330	165000

*According to drippers spacing

UNIRAM™ CNL 16010

Catalog number **13900** - (any of below 6 digits)

FLOW RATE (L/H)	DISTANCE BETWEEN DRIPPERS (M)													
	0.15	0.20	0.25	0.30	0.33	0.40	0.50	0.60	0.65	0.70	0.75	0.80	0.90	1.00
0.7		000250												
1.0	001000	001100	001150	001200	001230	001260	001300	001325			001350	001400	001800	002000
1.6	004400	004500	004550	004600	004630	004700	004800	004900	004950	004960	005000	005200		005300
2.3	005600	005700	005900	006000	006050	006200	006400	006500	006550	006670	006700	006800	006900	007000
3.5	007300	007350	007400	007500	007530	007600	007700	007900		008100	008200	008300	008400	008500
Bundled coil length (m)	500	500	500	500	500	500	500	500	500	500	500	500	500	500

Missing catalog numbers available upon request.

DRIPPERLINES TECHNICAL DATA

MODEL	INSIDE DIAMETER (MM)	WALL THICKNESS (MM)	OUTSIDE DIAMETER (MM)	MAX. WORKING PRESSURE (BAR)	MAXIMUM FLUSHING PRESSURE (BAR)	KD
16010	14.20	1.00	16.20	3.5	4.6	1.30

DRIPPERLINES PACKAGE DATA (ON BUNDLED COILS)

MODEL	WALL THICKNESS (MM)	COIL LENGTH (M)	DISTANCE BETWEEN DRIPPERS (M)	AVERAGE* COIL WEIGHT (KG)	COILS IN A 40 FEET CONTAINER (UNITS)	TOTAL IN A 40 FEET CONTAINER (M)
16010	1.00	500	0.15 to 1.00	22.1	330	165000

*According to drippers spacing

UNIRAM™ CNL 16012

Catalog number **13880** - (any of below 6 digits)

FLOW RATE (L/H)	DISTANCE BETWEEN DRIPPERS (M)													
	0.15	0.20	0.25	0.30	0.33	0.40	0.50	0.60	0.65	0.70	0.75	0.80	0.90	1.00
0.7	000050	000100					000400							
1.0	001095	001100	001150	001200		001300	001400	001500						002000
1.6	002800	002900	003000	003100	003150	003200	003300				003700	003800		004200
2.3	004700	004720	004900	005000	005150	005300	005400					005700		005850
3.5				006500	006510	006400	006700							007000
Bundled coil length (m)	400	400	400	400	400	400	400	400	400	400	400	400	400	400

Missing catalog numbers available upon request.

DRIPPERLINES TECHNICAL DATA

MODEL	INSIDE DIAMETER (MM)	WALL THICKNESS (MM)	OUTSIDE DIAMETER (MM)	MAX. WORKING PRESSURE (BAR)	MAXIMUM FLUSHING PRESSURE (BAR)	KD
16012	14.20	1.20	16.60	4.0	5.2	1.30

DRIPPERLINES PACKAGE DATA (ON BUNDLED COILS)

MODEL	WALL THICKNESS (MM)	COIL LENGTH (M)	DISTANCE BETWEEN DRIPPERS (M)	AVERAGE* COIL WEIGHT (KG)	COILS IN A 40 FEET CONTAINER (UNITS)	TOTAL IN A 40 FEET CONTAINER (M)
16012	1.20	400	0.15 to 1.00	21.2	352	140800

*According to drippers spacing

UNIRAM™ CNL 17012

Catalog number **14040** - (any of below 6 digits)

FLOW RATE (L/H)	DISTANCE BETWEEN DRIPPERS (M)													
	0.15	0.20	0.25	0.30	0.33	0.40	0.50	0.60	0.65	0.70	0.75	0.80	0.90	1.00
0.7		000005												
1.0	000035	000040	000045	000050		000070	000100	000120			000140	000160		000200
1.6	000300	000350	000400	000450	000467	000500	000550	000600				000750	000770	000800
2.3		000950	000970	001100	001150	001400	001600	001700	001730	001800	001900	002100	002200	002300
3.5			002950	003000	003020	003100	003200	003250		003300	003320	003350	003370	003400
Bundled coil length (m)	400	400	400	400	400	400	400	400	400	400	400	400	400	400

Missing catalog numbers available upon request.

DRIPPERLINES TECHNICAL DATA

MODEL	INSIDE DIAMETER (MM)	WALL THICKNESS (MM)	OUTSIDE DIAMETER (MM)	MAX. WORKING PRESSURE (BAR)	MAXIMUM FLUSHING PRESSURE (BAR)	KD
17012	14.60	1.20	1700	4.0	5.2	1.10

DRIPPERLINES PACKAGE DATA (ON BUNDLED COILS)

MODEL	WALL THICKNESS (MM)	COIL LENGTH (M)	DISTANCE BETWEEN DRIPPERS (M)	AVERAGE* COIL WEIGHT (KG)	COILS IN A 40 FEET CONTAINER (UNITS)	TOTAL IN A 40 FEET CONTAINER (M)
17012	1.20	400	0.15 to 1.00	22.4	352	140800

*According to drippers spacing

UNIRAM™ CNL 20010

Catalog number **14560** - (any of below 6 digits)

FLOW RATE (L/H)	DISTANCE BETWEEN DRIPPERS (M)													
	0.15	0.20	0.25	0.30	0.33	0.40	0.50	0.60	0.65	0.70	0.75	0.80	0.90	1.00
0.7														
1.0		000900	000950	001000		001200	001300	001400			001500	001550		002000
1.6	004200	004300	004400	004500		004600	004700	004800			004900	005000		005200
2.3		005500	005600	005700		005800	005900	006000			006100	006300		006500
3.5			006950	007000		007200	007300	007400			007500	007550		007600
Bundled coil length (m)	300	300	300	300	300	300	300	300	300	300	300	300	300	300

Missing catalog numbers available upon request.

DRIPPERLINES TECHNICAL DATA

MODEL	INSIDE DIAMETER (MM)	WALL THICKNESS (MM)	OUTSIDE DIAMETER (MM)	MAX. WORKING PRESSURE (BAR)	MAXIMUM FLUSHING PRESSURE (BAR)	KD
20010	17.50	1.00	19.50	3.5	4.6	0.40

DRIPPERLINES PACKAGE DATA (ON BUNDLED COILS)

MODEL	WALL THICKNESS (MM)	COIL LENGTH (M)	DISTANCE BETWEEN DRIPPERS (M)	AVERAGE* COIL WEIGHT (KG)	COILS IN A 40 FEET CONTAINER (UNITS)	TOTAL IN A 40 FEET CONTAINER (M)
20010	1.00	300	0.15 to 1.00	17.4	330	99000

*According to drippers spacing

UNIRAM™ CNL 20012

Catalog number **14540** - (any of below 6 digits)

FLOW RATE (L/H)	DISTANCE BETWEEN DRIPPERS (M)													
	0.15	0.20	0.25	0.30	0.33	0.40	0.50	0.60	0.65	0.70	0.75	0.80	0.90	1.00
0.7		007000				000030		007100						
1.0	000070	000100	000120	000140		000153	000160	000170			000180	000185	000190	000200
1.6		000400	000450	000500	000523	000550	000600	000650	000665		000680	000750	000780	000800
2.3	000890	000900	001050	001400	001510	001900	002100	002300		002500	002600	002700	002800	002900
3.5		003880	003900	004000	005450	004100	004200	004300	004350	004400	004500	004600	004700	004800
Bundled coil length (m)	300	300	300	300	300	300	300	300	300	300	300	300	300	300

Missing catalog numbers available upon request.

DRIPPERLINES TECHNICAL DATA

MODEL	INSIDE DIAMETER (MM)	WALL THICKNESS (MM)	OUTSIDE DIAMETER (MM)	MAX. WORKING PRESSURE (BAR)	MAXIMUM FLUSHING PRESSURE (BAR)	KD
20012	17.50	1.20	19.90	4.0	5.2	0.40

DRIPPERLINES PACKAGE DATA (ON BUNDLED COILS)

MODEL	WALL THICKNESS (MM)	COIL LENGTH (M)	DISTANCE BETWEEN DRIPPERS (M)	AVERAGE* COIL WEIGHT (KG)	COILS IN A 40 FEET CONTAINER (UNITS)	TOTAL IN A 40 FEET CONTAINER (M)
20012	1.20	300	0.15 to 1.00	20.2	330	99000

*According to drippers spacing

UNIRAM™ CNL 23010

Catalog number **14625** - (any of below 6 digits)

FLOW RATE (L/H)	DISTANCE BETWEEN DRIPPERS (M)													
	0.15	0.20	0.25	0.30	0.33	0.40	0.50	0.60	0.65	0.70	0.75	0.80	0.90	1.00
0.7						000800		000850						
1.0				001500		001600	001700	001900	001950					
1.6						002800	002900	003000	003100					
2.3						003850	003900	004100		004200				
3.5						005400	005450	005500	005600		005700	005800		006100
Carton coil length (m)	200	200	200	300	300	300	300	300	300	300	300	300	300	300

Missing catalog numbers available upon request.

DRIPPERLINES TECHNICAL DATA

MODEL	INSIDE DIAMETER (MM)	WALL THICKNESS (MM)	OUTSIDE DIAMETER (MM)	MAX. WORKING PRESSURE (BAR)	MAXIMUM FLUSHING PRESSURE (BAR)	KD
23010	20.80	1.00	22.80	3.0	3.5	0.30

DRIPPERLINES PACKAGE DATA (ON CARTON COILS)

MODEL	WALL THICKNESS (MM)	COIL LENGTH (M)	DISTANCE BETWEEN DRIPPERS (M)	AVERAGE* COIL WEIGHT (KG)	COILS IN A 40 FEET CONTAINER (UNITS)	TOTAL IN A 40 FEET CONTAINER (M)
23010	1.00	200	0.15 to 0.25	14.7	480	96000
		300	0.30 to 1.00	20.7		144000

*According to drippers spacing





UNIRAM™ HCNL

INTEGRAL PRESSURE-COMPENSATING,
CONTINUOUSLY SELF-CLEANING, ANTI-SIPHON AND
HIGH ANTI-DRAIN MECHANISM DRIPPER



16009 - 16010 - 16012 - 17012 - 20010 - 20012 - 23010

APPLICATIONS

- Greenhouse, deciduous and tree irrigation.
- Precise Irrigation, Multiple pulse irrigation

FEATURES AND BENEFITS

- Pressure compensated: Precise and equal amounts of water are delivered over a broad pressure range. 100 % uniformity of water and nutrient distribution along the laterals.
- Anti-Siphon mechanism: Prevents contaminants from being drawn into the dripper, which is needed in sub surface applications.
- High Anti-drain (HCNL) system: Eliminates drainage and refill effect, and improves efficiency in pulse irrigation.
- Continuously self flushing: Continuously flushing debris, throughout operation, not just at the beginning or end of a cycle, ensuring uninterrupted dripper operation.
- Self-flushing system with wide filtration area improves resistance to clogging thus making UniRam™ highly resistant when using low quality water, which leads in reduction in filtration requirements, hence increasing filtration efficiency.
- Physical root barrier: Better protection against root intrusion without reliance on chemicals.
- TurboNet™ labyrinth assures wide water passages, large deep and wide cross section improves clogging resistance.

SPECIFICATIONS

- Pressure-compensating range: 1.5-4.0 bar.
- Anti-Siphon and higher pressure range of the Anti-drain mechanism.
- Largest filter in each dripper. Recommended filtration: 130 micron / 120 mesh.
Filtration method is to be selected based on the kind and concentration of the dirt particles existing in the water. Wherever sand exceeding 2 ppm exists in the water, a Hydrocyclone is to be installed before the main filter. When sand/ silt/ clay solids exceed 100 ppm, pre treatment will be applied according to Netafim™ expert team's instructions.
- Double TurboNet™ labyrinth with large water passage.
- To be "welded" into thick-walled dripperlines (0.90, 1.00, 1.20 mm).
- Injected dripper, very low CV.
- Injected silicon diaphragm.
- High UV resistant. Resistant to standard nutrients used in agricultural.
- UniRam™ dripperlines meet ISO 9261 Standards with production certified by the Israel Standards Institute (SII).

DRIPPERS TECHNICAL DATA

FLOW RATE* (L/H)	WORKING PRESSURE RANGE (BAR)	WATER PASSAGES DIMENSIONS WIDTH-DEPTH-LENGTH (MM)	FILTRATION AREA (MM²)	CONSTANT K	EXPONENT* X	RECOMMENDED FILTRATION (MICRON)/(MESH)	SHUT OFF PRESSURE (BAR)
0.85	1.5 – 4.0	0.70 x 0.65 x 40	110	0.85	0	130/120	0.25
1.25	1.5 – 4.0	0.83 x 0.74 x 40	130	1.25	0	130/120	0.25
2.00	1.5 – 4.0	1.07 x 0.79 x 40	130	2.00	0	130/120	0.25
2.90	1.5 – 4.0	1.26 x 0.95 x 40	130	2.90	0	130/120	0.25
4.40	1.5 – 4.0	1.59 x 1.10 x 40	150	4.40	0	130/120	0.25

* Within working pressure range

UNIRAM™ HCNL 16009

Catalog number **13925** - (any of below 6 digits)

FLOW RATE (L/H)	DISTANCE BETWEEN DRIPPERS (M)													
	0.15	0.20	0.25	0.30	0.33	0.40	0.50	0.60	0.65	0.70	0.75	0.80	0.90	1.00
0.85			000001	002045		002200	002210							
1.25	003880	003900		004000										
2.00						005400	005470							
2.90														
4.40														
Bundled coil length (m)	500	500	500	500	500	500	500	500	500	500	500	500	500	500

Missing catalog numbers available upon request.

DRIPPERLINES TECHNICAL DATA

MODEL	INSIDE DIAMETER (MM)	WALL THICKNESS (MM)	OUTSIDE DIAMETER (MM)	MAX. WORKING PRESSURE (BAR)	MAXIMUM FLUSHING PRESSURE (BAR)	KD
16009	14.20	0.90	16.00	3.0	3.9	1.30

DRIPPERLINES PACKAGE DATA (ON BUNDLED COILS)

MODEL	WALL THICKNESS (MM)	COIL LENGTH (M)	DISTANCE BETWEEN DRIPPERS (M)	AVERAGE* COIL WEIGHT (KG)	COILS IN A 40 FEET CONTAINER (UNITS)	TOTAL IN A 40 FEET CONTAINER (M)
16009	0.90	500	0.15 to 1.00	20.3	330	165000

*According to drippers spacing

UNIRAM™ HCNL 16010

Catalog number **13910** - (any of below 6 digits)

FLOW RATE (L/H)	DISTANCE BETWEEN DRIPPERS (M)													
	0.15	0.20	0.25	0.30	0.33	0.40	0.50	0.60	0.65	0.70	0.75	0.80	0.90	1.00
0.85		000800	000810	000900		001060	001080							
1.25		002000	002100	002400	002500	002600	002700							
2.00	003150	003230	003300	003400		003500	003600	003700					004000	
2.90			000001											004500
4.40							006660			006680				006600
Bundled coil length (m)	500	500	500	500	500	500	500	500	500	500	500	500	500	500

Missing catalog numbers available upon request.

DRIPPERLINES TECHNICAL DATA

MODEL	INSIDE DIAMETER (MM)	WALL THICKNESS (MM)	OUTSIDE DIAMETER (MM)	MAX. WORKING PRESSURE (BAR)	MAXIMUM FLUSHING PRESSURE (BAR)	KD
16010	14.20	1.00	16.20	3.5	4.6	1.30

DRIPPERLINES PACKAGE DATA (ON BUNDLED COILS)

MODEL	WALL THICKNESS (MM)	COIL LENGTH (M)	DISTANCE BETWEEN DRIPPERS (M)	AVERAGE* COIL WEIGHT (KG)	COILS IN A 40 FEET CONTAINER (UNITS)	TOTAL IN A 40 FEET CONTAINER (M)
16010	1.00	500	0.15 to 1.00	22.1	330	165000

*According to drippers spacing

UNIRAM™ HCNL 16012

Catalog number **13870** - (any of below 6 digits)

FLOW RATE (L/H)	DISTANCE BETWEEN DRIPPERS (M)													
	0.15	0.20	0.25	0.30	0.33	0.40	0.50	0.60	0.65	0.70	0.75	0.80	0.90	1.00
0.85		000001												
1.25				004000										
2.00				005290		005300	005400							
2.90														
4.40														
Bundled coil length (m)	400	400	400	400	400	400	400	400	400	400	400	400	400	400

Missing catalog numbers available upon request.

DRIPPERLINES TECHNICAL DATA

MODEL	INSIDE DIAMETER (MM)	WALL THICKNESS (MM)	OUTSIDE DIAMETER (MM)	MAX. WORKING PRESSURE (BAR)	MAXIMUM FLUSHING PRESSURE (BAR)	KD
16012	14.20	1.20	16.60	4.0	5.2	1.30

DRIPPERLINES PACKAGE DATA (ON BUNDLED COILS)

MODEL	WALL THICKNESS (MM)	COIL LENGTH (M)	DISTANCE BETWEEN DRIPPERS (M)	AVERAGE* COIL WEIGHT (KG)	COILS IN A 40 FEET CONTAINER (UNITS)	TOTAL IN A 40 FEET CONTAINER (M)
16012	1.20	400	0.15 to 1.00	21.2	352	140800

*According to drippers spacing

UNIRAM™ HCNL 17012

Catalog number **14050** - (any of below 6 digits)

FLOW RATE (L/H)	DISTANCE BETWEEN DRIPPERS (M)													
	0.15	0.20	0.25	0.30	0.33	0.40	0.50	0.60	0.65	0.70	0.75	0.80	0.90	1.00
0.85														
1.25		002000	002060			002400								
2.00		003200		003300		003320	003600							
2.90														
4.40		005000				000001	000002							
Bundled coil length (m)	400	400	400	400	400	400	400	400	400	400	400	400	400	400

Missing catalog numbers available upon request.

DRIPPERLINES TECHNICAL DATA

MODEL	INSIDE DIAMETER (MM)	WALL THICKNESS (MM)	OUTSIDE DIAMETER (MM)	MAX. WORKING PRESSURE (BAR)	MAXIMUM FLUSHING PRESSURE (BAR)	KD
17012	14.60	1.20	17.00	4.0	5.2	1.10

DRIPPERLINES PACKAGE DATA (ON BUNDLED COILS)

MODEL	WALL THICKNESS (MM)	COIL LENGTH (M)	DISTANCE BETWEEN DRIPPERS (M)	AVERAGE* COIL WEIGHT (KG)	COILS IN A 40 FEET CONTAINER (UNITS)	TOTAL IN A 40 FEET CONTAINER (M)
17012	1.20	400	0.15 to 1.00	22.4	352	140800

*According to drippers spacing

UNIRAM™ HCNL 20010

Catalog number **14565** - (any of below 6 digits)

FLOW RATE (L/H)	DISTANCE BETWEEN DRIPPERS (M)													
	0.15	0.20	0.25	0.30	0.33	0.40	0.50	0.60	0.65	0.70	0.75	0.80	0.90	1.00
0.85		000630		000640		000650								
1.25		001290		001300			001500							
2.00				002300				002400						
2.90							003500							
4.40							004500							
Bundled coil length (m)	300	300	300	300	300	300	300	300	300	300	300	300	300	300

Missing catalog numbers available upon request.

DRIPPERLINES TECHNICAL DATA

MODEL	INSIDE DIAMETER (MM)	WALL THICKNESS (MM)	OUTSIDE DIAMETER (MM)	MAX. WORKING PRESSURE (BAR)	MAXIMUM FLUSHING PRESSURE (BAR)	KD
20010	17.50	1.00	19.50	3.5	4.6	0.40

DRIPPERLINES PACKAGE DATA (ON BUNDLED COILS)

MODEL	WALL THICKNESS (MM)	COIL LENGTH (M)	DISTANCE BETWEEN DRIPPERS (M)	AVERAGE* COIL WEIGHT (KG)	COILS IN A 40 FEET CONTAINER (UNITS)	TOTAL IN A 40 FEET CONTAINER (M)
20010	1.00	300	0.15 to 1.00	17.4	330	99000

*According to drippers spacing

UNIRAM™ HCNL 20012

Catalog number **14550** - (any of below 6 digits)

FLOW RATE (L/H)	DISTANCE BETWEEN DRIPPERS (M)													
	0.15	0.20	0.25	0.30	0.33	0.40	0.50	0.60	0.65	0.70	0.75	0.80	0.90	1.00
0.85		000100	000110					000200						
1.25	000980	001000	001090	001100		001200	001300	001500			001650		001750	001800
2.00			001900	002000		002300	002400	002500		002800	002850		002900	002950
2.90				003100		003150	003200	003250	003265		003300		003350	003400
4.40				004000		004100	004200	004300			004600	004700	004800	005000
Bundled coil length (m)	300	300	300	300	300	300	300	300	300	300	300	300	300	300

Missing catalog numbers available upon request.

DRIPPERLINES TECHNICAL DATA

MODEL	INSIDE DIAMETER (MM)	WALL THICKNESS (MM)	OUTSIDE DIAMETER (MM)	MAX. WORKING PRESSURE (BAR)	MAXIMUM FLUSHING PRESSURE (BAR)	KD
20012	17.50	1.20	19.90	4.0	5.2	0.40

DRIPPERLINES PACKAGE DATA (ON BUNDLED COILS)

MODEL	WALL THICKNESS (MM)	COIL LENGTH (M)	DISTANCE BETWEEN DRIPPERS (M)	AVERAGE* COIL WEIGHT (KG)	COILS IN A 40 FEET CONTAINER (UNITS)	TOTAL IN A 40 FEET CONTAINER (M)
20012	1.20	300	0.15 to 1.00	20.2	330	99000

*According to drippers spacing

UNIRAM™ HCNL 23010

Catalog number **14645** - (any of below 6 digits)

FLOW RATE (L/H)	DISTANCE BETWEEN DRIPPERS (M)													
	0.15	0.20	0.25	0.30	0.33	0.40	0.50	0.60	0.65	0.70	0.75	0.80	0.90	1.00
0.85														
1.25								001500						
2.00							002500	002600					003000	
2.90									004100					
4.40														006200
Carton coil length (m)	200	200	200	300	300	300	300	300	300	300	300	300	300	300

Missing catalog numbers available upon request.

DRIPPERLINES TECHNICAL DATA

MODEL	INSIDE DIAMETER (MM)	WALL THICKNESS (MM)	OUTSIDE DIAMETER (MM)	MAX. WORKING PRESSURE (BAR)	MAXIMUM FLUSHING PRESSURE (BAR)	KD
23010	20.80	1.00	22.80	3.0	3.5	0.30

DRIPPERLINES PACKAGE DATA (ON CARTON COILS)

MODEL	WALL THICKNESS (MM)	COIL LENGTH (M)	DISTANCE BETWEEN DRIPPERS (M)	AVERAGE* COIL WEIGHT (KG)	COILS IN A 40 FEET CONTAINER (UNITS)	TOTAL IN A 40 FEET CONTAINER (M)
23010	1.00	200	0.15 to 0.25	14.7	480	96000
		300	0.30 to 1.00	20.7		144000

*According to drippers spacing





UNIRAM™ RC

INTEGRAL PRESSURE-COMPENSATING,
CONTINUOUSLY SELF-CLEANING DRIPPER



16009 - 16010 - 16012 - 17012 - 20010 - 20012 - 23010

APPLICATIONS

- On surface deciduous plantation and tree irrigation.
- On-surface multi seasonal Row Crops.

FEATURES AND BENEFITS

- Pressure compensated: Precise and equal amounts of water are delivered over a broad pressure range. 100% uniformity of water and nutrient distribution along the laterals. The dripper associates draining mechanism that drain the water from the pipe in the end if the irrigation cycle, allowing easier recoiling of the dripperline in the end of the crop cycle.
- Continuously self flushing: Continuously flushing debris, throughout operation, not just at the beginning or end of a cycle, ensuring uninterrupted dripper operation.
- Self-flushing system with wide filtration area improves resistance to clogging thus making UniRam™ highly resistant when using low quality water, which leads in reduction in filtraion requirements, hence increasing filtration efficiency.
- Physical root barrier: Better protection against root intrusion without reliance on chemicals.
- TurboNet™ labyrinth assures wide water passages, large deep and wide cross section improves clogging resistance.

SPECIFICATIONS

- Pressure-compensating range: 0.5-4.0 bar.
- Largest filter in each dripper. Recommended filtration: according to drippers flow rate. Filtration method is to be selected based on the kind and concentration of the dirt particles existing in the water. Wherever sand exceeding 2 ppm exists in the water, a Hydrocyclone is to be installed before the main filter. When sand/ silt/ clay solids exceed 100 ppm, pre treatment will be applied according to Netafim™ expert team's instructions.
- Double TurboNet™ labyrinth with large water passage.
- To be "welded" into thick-walled dripperlines (0.90, 1.00, 1.20 mm).
- Injected dripper, very low CV.
- Injected silicon diaphragm.
- High UV resistance. Resistant to standard nutrients used in agricultural.
- UniRam™ dripperlines meet ISO 9261 Standards with production certified by the Israel Standards Institute (SII).

DRIPPERS TECHNICAL DATA

FLOW RATE* (L/H)	WORKING PRESSURE RANGE (BAR)	WATER PASSAGES DIMENSIONS WIDTH-DEPTH-LENGTH (MM)	FILTRATION AREA (MM²)	CONSTANT K	EXPONENT* X	RECOMMENDED FILTRATION (MICRON)/(MESH)
0.7	0.5 - 4.0	0.70 x 0.65 x 40	110	0.7	0	130/120
1.0	0.5 - 4.0	0.83 x 0.74 x 40	130	1.0	0	130/120
1.6	0.5 - 4.0	1.07 x 0.79 x 40	130	1.6	0	200/80
2.3	0.5 - 4.0	1.26 x 0.95 x 40	130	2.3	0	200/80
3.5	0.5 - 4.0	1.59 x 1.10 x 40	150	3.5	0	200/80

* Within working pressure range

UNIRAM™ RC 16009

Catalog number **13750** - (any of below 6 digits)

FLOW RATE (L/H)	DISTANCE BETWEEN DRIPPERS (M)													
	0.15	0.20	0.25	0.30	0.33	0.40	0.50	0.60	0.65	0.70	0.75	0.80	0.90	1.00
0.7		001400				001600								
1.0			002190	002200		002300	002400	002500		002550	002600	002700		002900
1.6				003200		003300	003400	003500	003560	003600	003700	003750		003900
2.3	004900			005100		005200	005300	005400	005500	005700	005810	005830	005900	006000
3.5						007000	007100	007200	007300	007350	007400	007500	007650	007700
Bundled coil length (m)	500	500	500	500	500	500	500	500	500	500	500	500	500	500

Missing catalog numbers available upon request.

DRIPPERLINES TECHNICAL DATA

MODEL	INSIDE DIAMETER (MM)	WALL THICKNESS (MM)	OUTSIDE DIAMETER (MM)	MAX. WORKING PRESSURE (BAR)	MAXIMUM FLUSHING PRESSURE (BAR)	KD
16009	14.20	0.90	16.00	3.0	3.9	1.30

DRIPPERLINES PACKAGE DATA (ON BUNDLED COILS)

MODEL	WALL THICKNESS (MM)	COIL LENGTH (M)	DISTANCE BETWEEN DRIPPERS (M)	AVERAGE* COIL WEIGHT (KG)	COILS IN A 40 FEET CONTAINER (UNITS)	TOTAL IN A 40 FEET CONTAINER (M)
16009	0.90	500	0.15 to 1.00	20.3	330	165000

*According to drippers spacing

UNIRAM™ RC 16010

Catalog number **13730** - (any of below 6 digits)

FLOW RATE (L/H)	DISTANCE BETWEEN DRIPPERS (M)													
	0.15	0.20	0.25	0.30	0.33	0.40	0.50	0.60	0.65	0.70	0.75	0.80	0.90	1.00
0.7		001000	001500	002000		002200	002400	002500		002600				
1.0	003700	003800	003900	004000	004100	004200	004400	004500			004600	004700		005000
1.6	006850	006900	006950	007000	007020	007200	007400	007520	007530	007550	007600	007700	007800	008000
2.3		009800	009900	010000	010100	010200	010400	010500	010520	010550	010600	010700	010800	011000
3.5			012900	013000	013100	013200	013400	013500	013520	013550	013600	013700	013900	014000
Bundled coil length (m)	500	500	500	500	500	500	500	500	500	500	500	500	500	500

Missing catalog numbers available upon request.

DRIPPERLINES TECHNICAL DATA

MODEL	INSIDE DIAMETER (MM)	WALL THICKNESS (MM)	OUTSIDE DIAMETER (MM)	MAX. WORKING PRESSURE (BAR)	MAXIMUM FLUSHING PRESSURE (BAR)	KD
16010	14.20	1.00	16.20	3.5	4.6	1.30

DRIPPERLINES PACKAGE DATA (ON BUNDLED COILS)

MODEL	WALL THICKNESS (MM)	COIL LENGTH (M)	DISTANCE BETWEEN DRIPPERS (M)	AVERAGE* COIL WEIGHT (KG)	COILS IN A 40 FEET CONTAINER (UNITS)	TOTAL IN A 40 FEET CONTAINER (M)
16010	1.00	500	0.15 to 1.00	22.1	330	165000

*According to drippers spacing

UNIRAM™ RC 16012

Catalog number **13890** - (any of below 6 digits)

FLOW RATE (L/H)	DISTANCE BETWEEN DRIPPERS (M)													
	0.15	0.20	0.25	0.30	0.33	0.40	0.50	0.60	0.65	0.70	0.75	0.80	0.90	1.00
0.7														
1.0		001290		001300		001400	001450							
1.6				001900		002000	002050							002550
2.3				003004	003020	003050	003100	003200	003250	003300	003400			003700
3.5				004550			004580	004600			004700			005000
Bundled coil length (m)	400	400	400	400	400	400	400	400	400	400	400	400	400	400

Missing catalog numbers available upon request.

DRIPPERLINES TECHNICAL DATA

MODEL	INSIDE DIAMETER (MM)	WALL THICKNESS (MM)	OUTSIDE DIAMETER (MM)	MAX. WORKING PRESSURE (BAR)	MAXIMUM FLUSHING PRESSURE (BAR)	KD
16012	14.20	1.20	16.60	4.0	5.2	1.30

DRIPPERLINES PACKAGE DATA (ON BUNDLED COILS)

MODEL	WALL THICKNESS (MM)	COIL LENGTH (M)	DISTANCE BETWEEN DRIPPERS (M)	AVERAGE* COIL WEIGHT (KG)	COILS IN A 40 FEET CONTAINER (UNITS)	TOTAL IN A 40 FEET CONTAINER (M)
16012	1.20	400	0.15 to 1.00	21.2	352	140800

*According to drippers spacing

UNIRAM™ RC 17012

Catalog number **14180** - (any of below 6 digits)

FLOW RATE (L/H)	DISTANCE BETWEEN DRIPPERS (M)													
	0.15	0.20	0.25	0.30	0.33	0.40	0.50	0.60	0.65	0.70	0.75	0.80	0.90	1.00
0.7		000100	000150	000200		000250	000550	000650		000002	000700	000730		001000
1.0		001620	001700	001800		001900	001980	002040			002200	002250	002270	002300
1.6		002500	002470	002600		002810	002920	003100	003123	003124	003130	003200	003320	003400
2.3		003860	003920	004000	004025	004050	004150	004170	004185	004190	004200	004220	004240	004260
3.5			004720	004800		004900	005000	005100			005300	005400		006000
Bundled coil length (m)	400	400	400	400	400	400	400	400	400	400	400	400	400	400

Missing catalog numbers available upon request.

DRIPPERLINES TECHNICAL DATA

MODEL	INSIDE DIAMETER (MM)	WALL THICKNESS (MM)	OUTSIDE DIAMETER (MM)	MAX. WORKING PRESSURE (BAR)	MAXIMUM FLUSHING PRESSURE (BAR)	KD
17012	14.60	1.20	1700	4.0	5.2	1.10

DRIPPERLINES PACKAGE DATA (ON BUNDLED COILS)

MODEL	WALL THICKNESS (MM)	COIL LENGTH (M)	DISTANCE BETWEEN DRIPPERS (M)	AVERAGE* COIL WEIGHT (KG)	COILS IN A 40 FEET CONTAINER (UNITS)	TOTAL IN A 40 FEET CONTAINER (M)
17012	1.20	400	0.15 to 1.00	22.4	352	140800

*According to drippers spacing

UNIRAM™ RC 20010

Catalog number **14570** - (any of below 6 digits)

FLOW RATE (L/H)	DISTANCE BETWEEN DRIPPERS (M)													
	0.15	0.20	0.25	0.30	0.33	0.40	0.50	0.60	0.65	0.70	0.75	0.80	0.90	1.00
0.7		000010	000030	000040		000050	000060	000070						
1.0		000300	000400	000450		000500	000550	000600			000650	000700		000750
1.6		001040	001050	001120		001200	001270	001300		001390	001400	001500	001600	001700
2.3			001950	002200		002300	002400	002500	002600	002650	002700	002800	002850	002900
3.5			003175	003200	003250	003300	003400	003500		003550	003700	003800	003900	004200
Bundled coil length (m)	300	300	300	300	300	300	300	300	300	300	300	300	300	300

Missing catalog numbers available upon request.

DRIPPERLINES TECHNICAL DATA

MODEL	INSIDE DIAMETER (MM)	WALL THICKNESS (MM)	OUTSIDE DIAMETER (MM)	MAX. WORKING PRESSURE (BAR)	MAXIMUM FLUSHING PRESSURE (BAR)	KD
20010	17.50	1.00	19.50	3.5	4.6	0.40

DRIPPERLINES PACKAGE DATA (ON BUNDLED COILS)

MODEL	WALL THICKNESS (MM)	COIL LENGTH (M)	DISTANCE BETWEEN DRIPPERS (M)	AVERAGE* COIL WEIGHT (KG)	COILS IN A 40 FEET CONTAINER (UNITS)	TOTAL IN A 40 FEET CONTAINER (M)
20010	1.00	300	0.15 to 1.00	17.4	330	99000

*According to drippers spacing

UNIRAM™ RC 20012

Catalog number **14420** - (any of below 6 digits)

FLOW RATE (L/H)	DISTANCE BETWEEN DRIPPERS (M)													
	0.15	0.20	0.25	0.30	0.33	0.40	0.50	0.60	0.65	0.70	0.75	0.80	0.90	1.00
0.7		000400	000450	000570		000650	000800	000850				000001		
1.0		001300	001500	001600	001770	001870	001920	002080			002400	002500	000003	002600
1.6		002800	002940	003000		003080	003300	003405			003440	003500		003700
2.3		004300	004400	004500		004650	004800	004870		004883	004900	004950		005200
3.5			005550	005600	005650	005700	005800	005850		005950	006000	006100		006200
Bundled coil length (m)	300	300	300	300	300	300	300	300	300	300	300	300	300	300

Missing catalog numbers available upon request.

DRIPPERLINES TECHNICAL DATA

MODEL	INSIDE DIAMETER (MM)	WALL THICKNESS (MM)	OUTSIDE DIAMETER (MM)	MAX. WORKING PRESSURE (BAR)	MAXIMUM FLUSHING PRESSURE (BAR)	KD
20012	17.50	1.20	19.90	4.0	5.2	0.40

DRIPPERLINES PACKAGE DATA (ON BUNDLED COILS)

MODEL	WALL THICKNESS (MM)	COIL LENGTH (M)	DISTANCE BETWEEN DRIPPERS (M)	AVERAGE* COIL WEIGHT (KG)	COILS IN A 40 FEET CONTAINER (UNITS)	TOTAL IN A 40 FEET CONTAINER (M)
20012	1.20	300	0.15 to 1.00	20.2	330	99000

*According to drippers spacing

UNIRAM™ RC 23010

Catalog number **14655** - (any of below 6 digits)

FLOW RATE (L/H)	DISTANCE BETWEEN DRIPPERS (M)													
	0.15	0.20	0.25	0.30	0.33	0.40	0.50	0.60	0.65	0.70	0.75	0.80	0.90	1.00
0.7				001100										
1.0							002300	002400						
1.6						003300	003500	003550						
2.3							004480	004500		004520				
3.5														
Carton coil length (m)	200	200	200	300	300	300	300	300	300	300	300	300	300	300

Missing catalog numbers available upon request.

DRIPPERLINES TECHNICAL DATA

MODEL	INSIDE DIAMETER (MM)	WALL THICKNESS (MM)	OUTSIDE DIAMETER (MM)	MAX. WORKING PRESSURE (BAR)	MAXIMUM FLUSHING PRESSURE (BAR)	KD
23010	20.80	1.00	22.80	3.0	3.5	0.30

DRIPPERLINES PACKAGE DATA (ON CARTON COILS)

MODEL	WALL THICKNESS (MM)	COIL LENGTH (M)	DISTANCE BETWEEN DRIPPERS (M)	AVERAGE* COIL WEIGHT (KG)	COILS IN A 40 FEET CONTAINER (UNITS)	TOTAL IN A 40 FEET CONTAINER (M)
23010	1.00	200	0.15 to 0.25	14.7	480	96000
		300	0.30 to 1.00	20.7		144000

*According to drippers spacing





UNIWINE™ AS

INTEGRAL PRESSURE-COMPENSATING, CONTINUOUSLY SELF-CLEANING, ANTI-SIPHON MECHANISM DRIPPER



16010 - 16012 - 17012 - 20010 - 20012

APPLICATIONS

Vineyards sub-surface multi seasonal installations.

FEATURES AND BENEFITS

- Pressure compensated: Precise and equal amounts of water are delivered over a broad pressure range. 100 % uniformity of water and nutrient distribution along the laterals.
- Anti-Siphon mechanism: Prevents contaminants from being drawn into the dripper, which is needed in sub surface applications.
- Continuously self flushing: Continuously flushing debris, throughout operation, not just at the beginning or end of a cycle, ensuring uninterrupted dripper operation.
- Self-flushing system with wide filtration area improves resistance to clogging thus making UniWine™ highly resistant when using low quality water, which leads in reduction in filtration requirements, hence increasing filtration efficiency.
- Physical root barrier: Better protection against root intrusion without reliance on chemicals.
- TurboNet™ labyrinth assures wide water passages, large deep and wide cross section improves clogging resistance.
- 2 purple strips to easily identification.

SPECIFICATIONS

- Pressure-compensating range: 0.5-4.0 bar.
- Anti-Siphon mechanism.
- Largest filter in each dripper. Recommended filtration: according to drippers flow rate.
- Filtration method id to be selected based on the kind and concentration of the dirt particles existing in the water. Wherever sand exceeding 2 ppm exists in the water, a Hydrocyclone is to be installed before the main filter. When sand/silt/clay exceed 100 ppm , pre treatment well be applied according to Netafim™ expert team's instructions.
- Double TurboNet™ labyrinth with large water passage.
- To be "welded" into thick-walled pipes (1.00, 1.20 mm).
- Injected dripper, very low CV.
- Injected silicon diaphragm.
- High UV resistant. Resistant to standard nutrients used in agricultural.
- UniWine™ dripperlines meet ISO 9261 Standards with production certified by the Israel Standards Institute (SII).

DRIPPERS TECHNICAL DATA

FLOW RATE* (L/H)	WORKING PRESSURE RANGE (BAR)	WATER PASSAGES DIMENSIONS WIDTH-DEPTH-LENGTH (MM)	FILTRATION AREA (MM²)	CONSTANT K	EXPONENT* X	RECOMMENDED FILTRATION (MICRON)/(MESH)
0.7	0.5 - 4.0	0.70 x 0.65 x 40	110	0.7	0	130/120
1.0	0.5 - 4.0	0.83 x 0.74 x 40	130	1.0	0	130/120
1.6	0.5 - 4.0	1.07 x 0.79 x 40	130	1.6	0	200/80
2.3	0.5 - 4.0	1.26 x 0.95 x 40	130	2.3	0	200/80
3.5	0.5 - 4.0	1.59 x 1.10 x 40	150	3.5	0	200/80

* Within working pressure range

UNIWINETM AS 16010

Catalog number **14740** - (any of below 6 digits)

FLOW RATE (L/H)	DISTANCE BETWEEN DRIPPERS (M)													
	0.15	0.20	0.25	0.30	0.33	0.40	0.50	0.60	0.65	0.70	0.75	0.80	0.90	1.00
0.7														
1.0							001140							001420
1.6								001830		001850				002220
2.3								002820						003350
3.5														
Bundled coil length (m)	500	500	500	500	500	500	500	500	500	500	500	500	500	500

Missing catalog numbers available upon request.

DRIPPERLINES TECHNICAL DATA

MODEL	INSIDE DIAMETER (MM)	WALL THICKNESS (MM)	OUTSIDE DIAMETER (MM)	MAX. WORKING PRESSURE (BAR)	MAXIMUM FLUSHING PRESSURE (BAR)	KD
16010	14.20	1.00	16.20	3.5	4.6	1.30

DRIPPERLINES PACKAGE DATA (ON BUNDLED COILS)

MODEL	WALL THICKNESS (MM)	COIL LENGTH (M)	DISTANCE BETWEEN DRIPPERS (M)	AVERAGE* COIL WEIGHT (KG)	COILS IN A 40 FEET CONTAINER (UNITS)	TOTAL IN A 40 FEET CONTAINER (M)
16010	1.00	500	0.15 to 1.00	22.1	330	165000

*According to drippers spacing

UNIWINETM AS 16010 - WITH ASSEMBLY CLIP

Catalog number : **14740** - (any of below 6 digits)

FLOW RATE (L/H)	DISTANCE BETWEEN DRIPPERS (M)													
	0.15	0.20	0.25	0.30	0.33	0.40	0.50	0.60	0.65	0.70	0.75	0.80	0.90	1.00
0.7				000900										
1.0				001050		001100	001150	001200			001250		001300	001400
1.6						001590	001640	001800		001870	001900	002000	002100	002200
2.3				002500		002600	002700	002800		002850	002900	003000	003100	003300
3.5						004000	004200	004400			004600			004900
Bundled coil length (m)	300	300	300	300	300	300	300	300	300	300	300	300	300	300

Missing catalog numbers available upon request.

DRIPPERLINES TECHNICAL DATA

MODEL	INSIDE DIAMETER (MM)	WALL THICKNESS (MM)	OUTSIDE DIAMETER (MM)	MAX. WORKING PRESSURE (BAR)	MAXIMUM FLUSHING PRESSURE (BAR)	KD
16010	14.20	1.00	16.20	3.5	4.6	1.30

DRIPPERLINES PACKAGE DATA (ON BUNDLED COILS)

MODEL	WALL THICKNESS (MM)	COIL LENGTH (M)	DISTANCE BETWEEN DRIPPERS (M)	AVERAGE* COIL WEIGHT (KG)	COILS IN A 40 FEET CONTAINER (UNITS)	TOTAL IN A 40 FEET CONTAINER (M)
16010	1.00	300	0.15 to 1.00	14.4	330	99000

*According to drippers spacing

UNIWINET™ AS 16012 - WITH ASSEMBLY CLIP

Catalog number : 14715 - (any of bellow 6 digits)

FLOW RATE (L/H)	DISTANCE BETWEEN DRIPPERS (M)													
	0.15	0.20	0.25	0.30	0.33	0.40	0.50	0.60	0.65	0.70	0.75	0.80	0.90	1.00
0.7														
1.0								001000						
1.6							001500							
2.3						003200	003500	003800		003900	003950	004000	004100	
3.5														
Bundled coil length (m)	300	300	300	300	300	300	300	300	300	300	300	300	300	300

Missing catalog numbers available upon request.

DRIPPERLINES TECHNICAL DATA

MODEL	INSIDE DIAMETER (MM)	WALL THICKNESS (MM)	OUTSIDE DIAMETER (MM)	MAX. WORKING PRESSURE (BAR)	MAXIMUM FLUSHING PRESSURE (BAR)	KD
16012	14.20	1.20	16.6	4.0	5.2	1.30

DRIPPERLINES PACKAGE DATA (ON BUNDLED COILS)

MODEL	WALL THICKNESS (MM)	COIL LENGTH (M)	DISTANCE BETWEEN DRIPPERS (M)	AVERAGE* COIL WEIGHT (KG)	COILS IN A 40 FEET CONTAINER (UNITS)	TOTAL IN A 40 FEET CONTAINER (M)
16012	1.20	300	0.15 to 1.00	172	330	99000

*According to drippers spacing

UNIWINET™ AS 17012 - WITH ASSEMBLY CLIP

Catalog number : 14820 - (any of bellow 6 digits)

FLOW RATE (L/H)	DISTANCE BETWEEN DRIPPERS (M)													
	0.15	0.20	0.25	0.30	0.33	0.40	0.50	0.60	0.65	0.70	0.75	0.80	0.90	1.00
0.7														
1.0														
1.6							001500	001600						
2.3						003000	003050	003100			003500		003900	
3.5														
Bundled coil length (m)	300	300	300	300	300	300	300	300	300	300	300	300	300	300

Missing catalog numbers available upon request.

DRIPPERLINES TECHNICAL DATA

MODEL	INSIDE DIAMETER (MM)	WALL THICKNESS (MM)	OUTSIDE DIAMETER (MM)	MAX. WORKING PRESSURE (BAR)	MAXIMUM FLUSHING PRESSURE (BAR)	KD
17012	14.60	1.20	17.00	4.0	5.2	1.10

DRIPPERLINES PACKAGE DATA (ON BUNDLED COILS)

MODEL	WALL THICKNESS (MM)	COIL LENGTH (M)	DISTANCE BETWEEN DRIPPERS (M)	AVERAGE* COIL WEIGHT (KG)	COILS IN A 40 FEET CONTAINER (UNITS)	TOTAL IN A 40 FEET CONTAINER (M)
17012	1.20	300	0.15 to 1.00	177	330	132000

*According to drippers spacing

UNIWINET™ AS 20010

Catalog number **14995** - (any of below 6 digits)

FLOW RATE (L/H)	DISTANCE BETWEEN DRIPPERS (M)													
	0.15	0.20	0.25	0.30	0.33	0.40	0.50	0.60	0.65	0.70	0.75	0.80	0.90	1.00
0.7														
1.0														
1.6														
2.3								003010						
3.5								005010						
Bundled coil length (m)	300	300	300	300	300	300	300	300	300	300	300	300	300	300

Missing catalog numbers available upon request.

DRIPPERLINES TECHNICAL DATA

MODEL	INSIDE DIAMETER (MM)	WALL THICKNESS (MM)	OUTSIDE DIAMETER (MM)	MAX. WORKING PRESSURE (BAR)	MAXIMUM FLUSHING PRESSURE (BAR)	KD
20010	17.50	1.00	19.50	3.5	4.6	0.40

DRIPPERLINES PACKAGE DATA (ON BUNDLED COILS)

MODEL	WALL THICKNESS (MM)	COIL LENGTH (M)	DISTANCE BETWEEN DRIPPERS (M)	AVERAGE* COIL WEIGHT (KG)	COILS IN A 40 FEET CONTAINER (UNITS)	TOTAL IN A 40 FEET CONTAINER (M)
20010	1.00	300	0.15 to 1.00	17.4	330	99000

*According to drippers spacing

UNIWINET™ AS 20010 - WITH ASSEMBLY CLIP

Catalog number **14995** - (any of below 6 digits)

FLOW RATE (L/H)	DISTANCE BETWEEN DRIPPERS (M)													
	0.15	0.20	0.25	0.30	0.33	0.40	0.50	0.60	0.65	0.70	0.75	0.80	0.90	1.00
0.7														
1.0														
1.6						001900	002000	002100				002400		
2.3						002900	002850	003000				003500	003700	003800
3.5								005000						
Bundled coil length (m)	300	300	300	300	300	300	300	300	300	300	300	300	300	300

Missing catalog numbers available upon request.

DRIPPERLINES TECHNICAL DATA

MODEL	INSIDE DIAMETER (MM)	WALL THICKNESS (MM)	OUTSIDE DIAMETER (MM)	MAX. WORKING PRESSURE (BAR)	MAXIMUM FLUSHING PRESSURE (BAR)	KD
20010	17.50	1.00	19.50	3.5	4.6	0.40

DRIPPERLINES PACKAGE DATA (ON BUNDLED COILS)

MODEL	WALL THICKNESS (MM)	COIL LENGTH (M)	DISTANCE BETWEEN DRIPPERS (M)	AVERAGE* COIL WEIGHT (KG)	COILS IN A 40 FEET CONTAINER (UNITS)	TOTAL IN A 40 FEET CONTAINER (M)
20010	1.00	300	0.15 to 1.00	17.5	330	99000

*According to drippers spacing

UNIWINET™ AS 20012

Catalog number **14980** - (any of below 6 digits)

FLOW RATE (L/H)	DISTANCE BETWEEN DRIPPERS (M)													
	0.15	0.20	0.25	0.30	0.33	0.40	0.50	0.60	0.65	0.70	0.75	0.80	0.90	1.00
0.7														
1.0														002020
1.6														002920
2.3								003505						004010
3.5														
Bundled coil length (m)	300	300	300	300	300	300	300	300	300	300	300	300	300	300

Missing catalog numbers available upon request.

DRIPPERLINES TECHNICAL DATA

MODEL	INSIDE DIAMETER (MM)	WALL THICKNESS (MM)	OUTSIDE DIAMETER (MM)	MAX. WORKING PRESSURE (BAR)	MAXIMUM FLUSHING PRESSURE (BAR)	KD
20012	1750	1.20	19.90	4.0	5.2	0.40

DRIPPERLINES PACKAGE DATA (ON BUNDLED COILS)

MODEL	WALL THICKNESS (MM)	COIL LENGTH (M)	DISTANCE BETWEEN DRIPPERS (M)	AVERAGE* COIL WEIGHT (KG)	COILS IN A 40 FEET CONTAINER (UNITS)	TOTAL IN A 40 FEET CONTAINER (M)
20012	1.20	300	0.15 to 1.00	20.2	330	99000

*According to drippers spacing

UNIWINET™ AS 20012 - WITH ASSEMBLY CLIP

Catalog number **14980** - (any of below 6 digits)

FLOW RATE (L/H)	DISTANCE BETWEEN DRIPPERS (M)													
	0.15	0.20	0.25	0.30	0.33	0.40	0.50	0.60	0.65	0.70	0.75	0.80	0.90	1.00
0.7														
1.0				001400		001500	001600	001700			001800		001950	002000
1.6				002200		002300	002400	002450			002550	002700	002800	002900
2.3				003200		003250		003480		003580	003600		003900	003990
3.5				005700		005800	005900	006000			006200		006400	006500
Bundled coil length (m)	200	200	200	200	200	200	200	200	200	200	200	200	200	200

Missing catalog numbers available upon request.

DRIPPERLINES TECHNICAL DATA

MODEL	INSIDE DIAMETER (MM)	WALL THICKNESS (MM)	OUTSIDE DIAMETER (MM)	MAX. WORKING PRESSURE (BAR)	MAXIMUM FLUSHING PRESSURE (BAR)	KD
20012	1750	1.20	19.90	4.0	5.2	0.40

DRIPPERLINES PACKAGE DATA (ON BUNDLED COILS)

MODEL	WALL THICKNESS (MM)	COIL LENGTH (M)	DISTANCE BETWEEN DRIPPERS (M)	AVERAGE* COIL WEIGHT (KG)	COILS IN A 40 FEET CONTAINER (UNITS)	TOTAL IN A 40 FEET CONTAINER (M)
20012	1.20	200	0.15 to 1.00	21.0	330	66000

*According to drippers spacing





UNIWIINE™ RC

INTEGRAL PRESSURE-COMPENSATING, CONTINUOUSLY SELF-CLEANING DRIPPER



16010 - 16012 - 20010 - 20012

APPLICATIONS

Vineyards on-surface or attached to the trellising multi seasonal installations.

FEATURES AND BENEFITS

- Pressure compensated: Precise and equal amounts of water are delivered over a broad pressure range. 100 % uniformity of water and nutrient distribution along the laterals.
- Continuously self flushing: Continuously flushing debris, throughout operation, not just at the beginning or end of a cycle, ensuring uninterrupted dripper operation.
- Self-flushing system with wide filtration area improves resistance to clogging thus making UniWine™ highly resistant when using low quality water, which leads in reduction in filtration requirements, hence increasing filtration efficiency.
- Physical root barrier: Better protection against root intrusion without reliance on chemicals.
- TurboNet™ labyrinth assures wide water passages, large deep and wide cross section improves clogging resistance.
- 2 purple strips to easily identification.
- Optional pre-assembled wine clip for easier trellising.



SPECIFICATIONS

- Pressure-compensating range: 0.5-4.0 bar.
- Largest filter in each dripper. Recommended filtration: according to drippers flow rate.
- Filtration method id to be selected based on the kind and concentration of the dirt particles existing in the water. Wherever sand exceeding 2 ppm exists in the water, a Hydrocyclone is to be installed before the main filter. When sand/silt/clay exceed 100 ppm, pre treatment well be applied according to Netafim™ expert team's instructions.
- Double TurboNet™ labyrinth with large water passage.
- To be "welded" into thick-walled pipes (1.00, 1.20 mm).
- Injected dripper, very low CV.
- Injected silicon diaphragm.
- UV resistant. Resistant to standard nutrients used in agricultural.
- UniWine™ dripperlines meet ISO 9261 Standards with production certified by the Israel Standards Institute (SII).

DRIPPERS TECHNICAL DATA

FLOW RATE* (L/H)	WORKING PRESSURE RANGE (BAR)	WATER PASSAGES DIMENSIONS WIDTH-DEPTH-LENGTH (MM)	FILTRATION AREA (MM²)	CONSTANT K	EXPONENT* X	RECOMMENDED FILTRATION (MICRON)/(MESH)
0.7	0.5 - 4.0	0.70 x 0.65 x 40	110	0.7	0	130/120
1.0	0.5 - 4.0	0.83 x 0.74 x 40	130	1.0	0	130/120
1.6	0.5 - 4.0	1.07 x 0.79 x 40	130	1.6	0	200/80
2.3	0.5 - 4.0	1.26 x 0.95 x 40	130	2.3	0	200/80
3.5	0.5 - 4.0	1.59 x 1.10 x 40	150	3.5	0	200/80

* Within working pressure range

UNIWINETM RC 16010 - WITH ASSEMBLY CLIP

Catalog number **14770** - (any of below 6 digits)

FLOW RATE (L/H)	DISTANCE BETWEEN DRIPPERS (M)													
	0.15	0.20	0.25	0.30	0.33	0.40	0.50	0.60	0.65	0.70	0.75	0.80	0.90	1.00
0.7														
1.0														002500
1.6							003800							004000
2.3							005500							006000
3.5														
Bundled coil length (m)	300	300	300	300	300	300	300	300	300	300	300	300	300	300

Missing catalog numbers available upon request.

DRIPPERLINES TECHNICAL DATA

MODEL	INSIDE DIAMETER (MM)	WALL THICKNESS (MM)	OUTSIDE DIAMETER (MM)	MAX. WORKING PRESSURE (BAR)	MAXIMUM FLUSHING PRESSURE (BAR)	KD
16010	14.20	1.00	16.20	3.5	4.6	1.30

DRIPPERLINES PACKAGE DATA (ON BUNDLED COILS)

MODEL	WALL THICKNESS (MM)	COIL LENGTH (M)	DISTANCE BETWEEN DRIPPERS (M)	AVERAGE* COIL WEIGHT (KG)	COILS IN A 40 FEET CONTAINER (UNITS)	TOTAL IN A 40 FEET CONTAINER (M)
16010	1.00	300	0.15 to 1.00	14.4	330	99000

*According to drippers spacing

UNIWINETM RC 20012 - WITH ASSEMBLY CLIP

Catalog number **14965** - (any of below 6 digits)

FLOW RATE (L/H)	DISTANCE BETWEEN DRIPPERS (M)													
	0.15	0.20	0.25	0.30	0.33	0.40	0.50	0.60	0.65	0.70	0.75	0.80	0.90	1.00
0.7														
1.0														002500
1.6														004000
2.3														006000
3.5														
Bundled coil length (m)	300	300	300	300	300	300	300	300	300	300	300	300	300	300

Missing catalog numbers available upon request.

DRIPPERLINES TECHNICAL DATA

MODEL	INSIDE DIAMETER (MM)	WALL THICKNESS (MM)	OUTSIDE DIAMETER (MM)	MAX. WORKING PRESSURE (BAR)	MAXIMUM FLUSHING PRESSURE (BAR)	KD
20012	17.50	1.20	19.90	4.0	5.2	0.40

DRIPPERLINES PACKAGE DATA (ON BUNDLED COILS)

MODEL	WALL THICKNESS (MM)	COIL LENGTH (M)	DISTANCE BETWEEN DRIPPERS (M)	AVERAGE* COIL WEIGHT (KG)	COILS IN A 40 FEET CONTAINER (UNITS)	TOTAL IN A 40 FEET CONTAINER (M)
20012	1.20	300	0.15 to 1.00	21.0	330	99000

*According to drippers spacing



UNIRAM™ AS XR

INTEGRAL PRESSURE-COMPENSATING, CONTINUOUSLY SELF-CLEANING, ANTI-SIPHON MECHANISM DRIPPER WITH IMPROVED RESISTANCE TO ROOT INTRUSION



16010 - 16012 - 20010 - 20012 - 23010

APPLICATIONS

- Sub-surface multi seasonal row crops.
- Intensive and multi seasonal irrigated crops (Alfalfa, turf, etc.).

FEATURES AND BENEFITS

- Crops are protected against root intrusion better than all other options, this is achieved by utilizing patented root inhibitor within the dripper cover that inhibits root intrusion into the dripper labyrinth.
- Physical root barrier: Better protection against root intrusion without reliance on chemicals.
- Long lasting protection due to non migrating protection materials embedded in the dripper cover.
- Pressure compensated: Precise and equal amounts of water are delivered over a broad pressure range. 100% uniformity of water and nutrient distribution along the laterals.
- Anti-Siphon mechanism: Prevents contaminants from being drawn into the dripper, which is needed in sub surface applications.
- Continuously self flushing: Continuously flushing debris, throughout operation, not just at the beginning or end of a cycle, ensuring uninterrupted dripper operation.
- Self-flushing system with wide filtration area improves resistance to clogging thus making UniRam™ highly resistant when using low quality water, which leads in reduction in filtration requirements, hence increasing filtration efficiency.
- TurboNet™ labyrinth assures wide water passages, large deep and wide cross section improves clogging resistance.
- The water is drawn in to the dripper from the stream center, preventing the entrance of sediments in to the drippers.

SPECIFICATIONS

- Pressure-compensating range: 0.5-4.0 bar.
- Anti-Siphon mechanism.
- Extra protection for root intrusion
- Largest filter in each dripper. Recommended filtration: according to drippers flow rate.
Filtration method is to be selected based on the kind and concentration of the dirt particles existing in the water. Wherever sand exceeding 2 ppm exists in the water, a Hydrocyclone is to be installed before the main filter. When sand/silt/clay solids exceed 100 ppm, pre treatment will be applied according to Netafim™ expert team's instructions.
- Double TurboNet™ labyrinth with large water passage.
- To be "welded" into thick-walled dripperlines (0.90, 1.00, 1.20 mm).
- Injected dripper, very low CV.
- Injected silicon diaphragm.
- High UV resistant. Resistant to standard nutrients used in agricultural.
- UniRam™ dripperlines meet ISO 9261 Standards with production certified by the Israel Standards Institute (SII).

DRIPPERS TECHNICAL DATA

FLOW RATE* (L/H)	WORKING PRESSURE RANGE (BAR)	WATER PASSAGES DIMENSIONS WIDTH-DEPTH-LENGTH (MM)	FILTRATION AREA (MM ²)	CONSTANT K	EXPONENT * X	RECOMMENDED FILTRATION (MICRON)/(MESH)
0.7	0.5 – 4.0	0.70 x 0.65 x 40	110	0.7	0	130/120
1.0	0.5 – 4.0	0.83 x 0.74 x 40	130	1.0	0	130/120
1.6	0.5 – 4.0	1.07 x 0.79 x 40	130	1.6	0	200/80
2.3	0.5 – 4.0	1.26 x 0.95 x 40	130	2.3	0	200/80
3.5	0.5 – 4.0	1.59 x 1.10 x 40	150	3.5	0	200/80

* Within working pressure range

UNIRAM™ AS XR 16010

Catalog number : 13735 - (any of bellow 6 digits)

FLOW RATE (L/H)	DISTANCE BETWEEN DRIPPERS (M)													
	0.15	0.20	0.25	0.30	0.33	0.40	0.50	0.60	0.65	0.70	0.75	0.80	0.90	1.00
0.7														
1.0						000880	000881	000900						001010
1.6				001410		001610	001710	001900			002010			
2.3				003310			003510	003530			003550			
3.5							005110							
Bundled coil length (m)	500	500	500	500	500	500	500	500	500	500	500	500	500	500

Missing catalog numbers available upon request.

DRIPPERLINES TECHNICAL DATA

MODEL	INSIDE DIAMETER (MM)	WALL THICKNESS (MM)	OUTSIDE DIAMETER (MM)	MAX. WORKING PRESSURE (BAR)	MAXIMUM FLUSHING PRESSURE (BAR)	KD
16010	14.20	1.00	16.20	3.5	4.6	1.30

DRIPPERLINES PACKAGE DATA (ON BUNDLED COILS)

MODEL	WALL THICKNESS (MM)	COIL LENGTH (M)	DISTANCE BETWEEN DRIPPERS (M)	AVERAGE* COIL WEIGHT (KG)	COILS IN A 40 FEET CONTAINER (UNITS)	TOTAL IN A 40 FEET CONTAINER (M)
16010	1.00	500	0.15 to 1.00	22.1	330	165000

*According to drippers spacing

UNIRAM™ AS XR 20010

Catalog number : 14380 - (any of bellow 6 digits)

FLOW RATE (L/H)	DISTANCE BETWEEN DRIPPERS (M)													
	0.15	0.20	0.25	0.30	0.33	0.40	0.50	0.60	0.65	0.70	0.75	0.80	0.90	1.00
0.7														
1.0				001000			001050							
1.6						001690	001720	001900			001930	002100		
2.3						004000	004030	004040			004070	004080		
3.5				005000		005030	005050							
Bundled coil length (m)	300	300	300	300	300	300	300	300	300	300	300	300	300	300

Missing catalog numbers available upon request.

DRIPPERLINES TECHNICAL DATA

MODEL	INSIDE DIAMETER (MM)	WALL THICKNESS (MM)	OUTSIDE DIAMETER (MM)	MAX. WORKING PRESSURE (BAR)	MAXIMUM FLUSHING PRESSURE (BAR)	KD
20010	17.50	1.00	19.50	3.5	4.6	0.40

DRIPPERLINES PACKAGE DATA (ON BUNDLED COILS)

MODEL	WALL THICKNESS (MM)	COIL LENGTH (M)	DISTANCE BETWEEN DRIPPERS (M)	AVERAGE* COIL WEIGHT (KG)	COILS IN A 40 FEET CONTAINER (UNITS)	TOTAL IN A 40 FEET CONTAINER (M)
20010	1.00	300	0.15 to 1.00	17.4	330	99000

*According to drippers spacing

UNIRAM™ AS XR 20012

Catalog number **14510** - (any of below 6 digits)

FLOW RATE (L/H)	DISTANCE BETWEEN DRIPPERS (M)													
	0.15	0.20	0.25	0.30	0.33	0.40	0.50	0.60	0.65	0.70	0.75	0.80	0.90	1.00
0.7														
1.0														001500
1.6				002580		002600	002700	002800						
2.3		004200		004220		004230	004600	004700				004770		004790
3.5						005690	005700							006200
Bundled coil length (m)	300	300	300	300	300	300	300	300	300	300	300	300	300	300

Missing catalog numbers available upon request.

DRIPPERLINES TECHNICAL DATA

MODEL	INSIDE DIAMETER (MM)	WALL THICKNESS (MM)	OUTSIDE DIAMETER (MM)	MAX. WORKING PRESSURE (BAR)	MAXIMUM FLUSHING PRESSURE (BAR)	KD
20012	17.50	1.20	19.90	4.0	5.2	0.40

DRIPPERLINES PACKAGE DATA (ON BUNDLED COILS)

MODEL	WALL THICKNESS (MM)	COIL LENGTH (M)	DISTANCE BETWEEN DRIPPERS (M)	AVERAGE* COIL WEIGHT (KG)	COILS IN A 40 FEET CONTAINER (UNITS)	TOTAL IN A 40 FEET CONTAINER (M)
20012	1.20	300	0.15 to 1.00	20.2	330	99000

*According to drippers spacing

UNIRAM™ AS XR 23010

Catalog number **14634** - (any of below 6 digits)

FLOW RATE (L/H)	DISTANCE BETWEEN DRIPPERS (M)													
	0.15	0.20	0.25	0.30	0.33	0.40	0.50	0.60	0.65	0.70	0.75	0.80	0.90	1.00
0.7														
1.0														
1.6							002500	002600						
2.3							003500	003510						
3.5							006100							006200
Bundled coil length (m)	200	200	200	300	300	300	300	300	300	300	300	300	300	300

Missing catalog numbers available upon request.

DRIPPERLINES TECHNICAL DATA

MODEL	INSIDE DIAMETER (MM)	WALL THICKNESS (MM)	OUTSIDE DIAMETER (MM)	MAX. WORKING PRESSURE (BAR)	MAXIMUM FLUSHING PRESSURE (BAR)	KD
23010	20.80	1.00	22.80	3.0	3.5	0.30

DRIPPERLINES PACKAGE DATA (ON BUNDLED COILS)

MODEL	WALL THICKNESS (MM)	COIL LENGTH (M)	DISTANCE BETWEEN DRIPPERS (M)	AVERAGE* COIL WEIGHT (KG)	COILS IN A 40 FEET CONTAINER (UNITS)	TOTAL IN A 40 FEET CONTAINER (M)
23010	1.00	200	0.15 to 0.25	14.7	480	96000
		300	0.15 to 1.00	20.7		144000

*According to drippers spacing



UNIGRAY™ CNL AND HCNL

INTEGRAL PRESSURE-COMPENSATING,
CONTINUOUSLY SELF-CLEANING, ANTI-SIPHON AND
ANTI-DRAIN MECHANISM DRIPPER



16009 - 16010 - 16012 - 17012 - 20010 - 20012

APPLICATIONS

Multi seasonal greenhouses, nurseries and open field crops.

FEATURES AND BENEFITS

- Pressure compensated: Precise and equal amounts of water are delivered over a broad pressure range. 100 % uniformity of water and nutrient distribution along the laterals.
- Anti-Siphon mechanism: Prevents contaminants from being drawn into the dripper, which is needed in sub surface applications.
- Anti-drain(CNL) system: Eliminates drainage and refill effect, and improves efficiency in pulse irrigation.
- Continuously self flushing: Continuously flushing debris, throughout operation, not just at the beginning or end of a cycle, ensuring uninterrupted dripper operation.
- Self-flushing system with wide filtration area improves resistance to clogging thus making UniRam™ highly resistant when using low quality water, which leads in reduction in filtration requirements, hence increasing filtration efficiency.
- Physical root barrier: Better protection against root intrusion without reliance on chemicals.
- TurboNet™ labyrinth assures wide water passages, large deep and wide cross section improves clogging resistance.
- Light gray outside color that absorbs less energy utilizing most of the radiation in the greenhouse.

SPECIFICATIONS

- Pressure-compensating range: according to the product model.
- Anti-Siphon and Anti-drain mechanism.
- Largest filter in each dripper. Recommended filtration: 130 micron.
Filtration method id to be selected based on the kind and concentration of the dirt particles existing in the water.
Wherever sand exceeding 2 ppm exists in the water, a Hydrocyclon is to be installed before the main filter.
When sand / silt / clay exceed 100 ppm, pre treatment well be applied according to Netafim™ expert team's instructions.
- Double TurboNet™ labyrinth with large water passage.
- To be "welded" into thick-walled pipes (0.90, 1.00, 1.20 mm).
- Injected dripper, very low CV.
- Injected silicon diaphragm.
- High UV resistant. Resistant to standard nutrients used in agricultural.
- UniRam™ dripperlines meet ISO 9261 Standards with production certified by the Israel Standards Institute (SII).

DRIPPERS TECHNICAL DATA – CNL MODEL

FLOW RATE* (L/H)	WORKING PRESSURE RANGE (BAR)	WATER PASSAGES DIMENSIONS WIDTH-DEPTH-LENGTH (MM)	FILTRATION AREA (MM ²)	CONSTANT K	EXPONENT * X	RECOMMENDED FILTRATION (MICRON)/(MESH)	SHUT OFF PRESSURE (BAR)
0.70	1.0 - 4.0	0.70 x 0.65 x 40	110	0.70	0	130/120	0.14
1.00	1.0 - 4.0	0.83 x 0.74 x 40	130	1.00	0	130/120	0.14
1.60	1.0 - 4.0	1.07 x 0.79 x 40	130	1.60	0	130/120	0.14
2.30	1.0 - 4.0	1.26 x 0.95 x 40	130	2.30	0	130/120	0.14
3.50	1.0 - 4.0	1.59 x 1.10 x 40	150	3.50	0	130/120	0.14

* Within working pressure range

DRIPPERS TECHNICAL DATA – HCNL MODEL

FLOW RATE* (L/H)	WORKING PRESSURE RANGE (BAR)	WATER PASSAGES DIMENSIONS WIDTH-DEPTH-LENGTH (MM)	FILTRATION AREA (MM ²)	CONSTANT K	EXPONENT * X	RECOMMENDED FILTRATION (MICRON)/(MESH)	SHUT OFF PRESSURE (BAR)
0.85	1.5 - 4.0	0.70 x 0.65 x 40	110	0.85	0	130/120	0.25
1.25	1.5 - 4.0	0.83 x 0.74 x 40	130	1.25	0	130/120	0.25
2.00	1.5 - 4.0	1.07 x 0.79 x 40	130	2.00	0	130/120	0.25
2.90	1.5 - 4.0	1.26 x 0.95 x 40	130	2.90	0	130/120	0.25
4.40	1.5 - 4.0	1.59 x 1.10 x 40	150	4.40	0	130/120	0.25

* Within working pressure range

UNIGRAY™ CNL 16010

Catalog number : 13980 - (any of bellow 6 digits)

FLOW RATE (L/H)	DISTANCE BETWEEN DRIPPERS (M)													
	0.15	0.20	0.25	0.30	0.33	0.40	0.50	0.60	0.65	0.70	0.75	0.80	0.90	1.00
0.7														
1.0														000950
1.6		002000					002030							
2.3		003490						006200	006210	006100				
3.5								007500					008000	
Bundled coil length (m)	500	500	500	500	500	500	500	500	500	500	500	500	500	500

Missing catalog numbers available upon request.

DRIPPERLINES TECHNICAL DATA

MODEL	INSIDE DIAMETER (MM)	WALL THICKNESS (MM)	OUTSIDE DIAMETER (MM)	MAX. WORKING PRESSURE (BAR)	MAXIMUM FLUSHING PRESSURE (BAR)	KD
16010	14.20	1.00	16.20	3.5	4.6	1.30

DRIPPERLINES PACKAGE DATA (ON BUNDLED COILS)

MODEL	WALL THICKNESS (MM)	COIL LENGTH (M)	DISTANCE BETWEEN DRIPPERS (M)	AVERAGE* COIL WEIGHT (KG)	COILS IN A 40 FEET CONTAINER (UNITS)	TOTAL IN A 40 FEET CONTAINER (M)
16010	1.00	500	0.15 to 1.00	22.1	330	165000

*According to drippers spacing

UNIGRAY™ CNL 160120

Catalog number : 13885 - (any of bellow 6 digits)

FLOW RATE (L/H)	DISTANCE BETWEEN DRIPPERS (M)													
	0.15	0.20	0.25	0.30	0.33	0.40	0.50	0.60	0.65	0.70	0.75	0.80	0.90	1.00
0.7														
1.0		002000												
1.6														
2.3			003000		003100	003120	003150				003190	003200		
3.5														
Bundled coil length (m)	400	400	400	400	400	400	400	400	400	400	400	400	400	400

Missing catalog numbers available upon request.

DRIPPERLINES TECHNICAL DATA

MODEL	INSIDE DIAMETER (MM)	WALL THICKNESS (MM)	OUTSIDE DIAMETER (MM)	MAX. WORKING PRESSURE (BAR)	MAXIMUM FLUSHING PRESSURE (BAR)	KD
16012	14.20	1.20	16.60	4.0	5.2	1.30

DRIPPERLINES PACKAGE DATA (ON BUNDLED COILS)

MODEL	WALL THICKNESS (MM)	COIL LENGTH (M)	DISTANCE BETWEEN DRIPPERS (M)	AVERAGE* COIL WEIGHT (KG)	COILS IN A 40 FEET CONTAINER (UNITS)	TOTAL IN A 40 FEET CONTAINER (M)
16012	1.20	400	0.15 to 1.00	21.2	352	140800

*According to drippers spacing

UNIGRAY™ CNL 17012

Catalog number : 14130 - (any of bellow 6 digits)

FLOW RATE (L/H)	DISTANCE BETWEEN DRIPPERS (M)													
	0.15	0.20	0.25	0.30	0.33	0.40	0.50	0.60	0.65	0.70	0.75	0.80	0.90	1.00
0.7														
1.0														
1.6							002550							
2.3		003500		003520		003530								
3.5							003990	004000	004005	004010		004013	004015	004020
Bundled coil length (m)	400	400	400	400	400	400	400	400	400	400	400	400	400	400

Missing catalog numbers available upon request.

DRIPPERLINES TECHNICAL DATA

MODEL	INSIDE DIAMETER (MM)	WALL THICKNESS (MM)	OUTSIDE DIAMETER (MM)	MAX. WORKING PRESSURE (BAR)	MAXIMUM FLUSHING PRESSURE (BAR)	KD
17012	14.60	1.20	17.00	4.0	5.2	1.10

DRIPPERLINES PACKAGE DATA (ON BUNDLED COILS)

MODEL	WALL THICKNESS (MM)	COIL LENGTH (M)	DISTANCE BETWEEN DRIPPERS (M)	AVERAGE* COIL WEIGHT (KG)	COILS IN A 40 FEET CONTAINER (UNITS)	TOTAL IN A 40 FEET CONTAINER (M)
17012	1.20	400	0.15 to 1.00	22.4	352	140800

*According to drippers spacing

UNIGRAY™ CNL 20012

Catalog number : 14440 - (any of bellow 6 digits)

FLOW RATE (L/H)	DISTANCE BETWEEN DRIPPERS (M)													
	0.15	0.20	0.25	0.30	0.33	0.40	0.50	0.60	0.65	0.70	0.75	0.80	0.90	1.00
0.7														
1.0														
1.6														
2.3		002990		003100										
3.5				004950			005000							
Bundled coil length (m)	300	300	300	300	300	300	300	300	300	300	300	300	300	300

Missing catalog numbers available upon request.

DRIPPERLINES TECHNICAL DATA

MODEL	INSIDE DIAMETER (MM)	WALL THICKNESS (MM)	OUTSIDE DIAMETER (MM)	MAX. WORKING PRESSURE (BAR)	MAXIMUM FLUSHING PRESSURE (BAR)	KD
20012	17.50	1.20	19.90	4.0	5.2	0.40

DRIPPERLINES PACKAGE DATA (ON BUNDLED COILS)

MODEL	WALL THICKNESS (MM)	COIL LENGTH (M)	DISTANCE BETWEEN DRIPPERS (M)	AVERAGE* COIL WEIGHT (KG)	COILS IN A 40 FEET CONTAINER (UNITS)	TOTAL IN A 40 FEET CONTAINER (M)
20012	1.20	300	0.15 to 1.00	20.2	330	99000

*According to drippers spacing

UNIGRAY™ HCNL 16010

Catalog number : 13985 - (any of bellow 6 digits)

FLOW RATE (L/H)	DISTANCE BETWEEN DRIPPERS (M)													
	0.15	0.20	0.25	0.30	0.33	0.40	0.50	0.60	0.65	0.70	0.75	0.80	0.90	1.00
0.85														
1.25														
2.00														
2.90														
4.40							006000			006050			006070	
Bundled coil length (m)	500	500	500	500	500	500	500	500	500	500	500	500	500	500

Missing catalog numbers available upon request.

DRIPPERLINES TECHNICAL DATA

MODEL	INSIDE DIAMETER (MM)	WALL THICKNESS (MM)	OUTSIDE DIAMETER (MM)	MAX. WORKING PRESSURE (BAR)	MAXIMUM FLUSHING PRESSURE (BAR)	KD
16010	14.20	1.00	16.20	3.5	4.6	1.30

DRIPPERLINES PACKAGE DATA (ON BUNDLED COILS)

MODEL	WALL THICKNESS (MM)	COIL LENGTH (M)	DISTANCE BETWEEN DRIPPERS (M)	AVERAGE* COIL WEIGHT (KG)	COILS IN A 40 FEET CONTAINER (UNITS)	TOTAL IN A 40 FEET CONTAINER (M)
16010	1.00	500	0.15 to 1.00	22.1	330	165000

*According to drippers spacing

UNIGRAY™ HCNL 16012

Catalog number : 13995 - (any of bellow 6 digits)

FLOW RATE (L/H)	DISTANCE BETWEEN DRIPPERS (M)													
	0.15	0.20	0.25	0.30	0.33	0.40	0.50	0.60	0.65	0.70	0.75	0.80	0.90	1.00
0.85														
1.25														
2.00				003980			004000	004040		004050				004080
2.90														
4.40								007000						
Bundled coil length (m)	400	400	400	400	400	400	400	400	400	400	400	400	400	400

Missing catalog numbers available upon request.

DRIPPERLINES TECHNICAL DATA

MODEL	INSIDE DIAMETER (MM)	WALL THICKNESS (MM)	OUTSIDE DIAMETER (MM)	MAX. WORKING PRESSURE (BAR)	MAXIMUM FLUSHING PRESSURE (BAR)	KD
16012	14.20	1.20	16.60	4.0	5.2	1.30

DRIPPERLINES PACKAGE DATA (ON BUNDLED COILS)

MODEL	WALL THICKNESS (MM)	COIL LENGTH (M)	DISTANCE BETWEEN DRIPPERS (M)	AVERAGE* COIL WEIGHT (KG)	COILS IN A 40 FEET CONTAINER (UNITS)	TOTAL IN A 40 FEET CONTAINER (M)
16012	1.20	400	0.15 to 1.00	21.2	352	140800

*According to drippers spacing

UNIGRAY™ CNL 17012

Catalog number : 14135 - (any of bellow 6 digits)

FLOW RATE (L/H)	DISTANCE BETWEEN DRIPPERS (M)													
	0.15	0.20	0.25	0.30	0.33	0.40	0.50	0.60	0.65	0.70	0.75	0.80	0.90	1.00
0.85														
1.25														
2.00					002500									
2.90														
4.40							004900	004930					005000	
Bundled coil length (m)	400	400	400	400	400	400	400	400	400	400	400	400	400	400

Missing catalog numbers available upon request.

DRIPPERLINES TECHNICAL DATA

MODEL	INSIDE DIAMETER (MM)	WALL THICKNESS (MM)	OUTSIDE DIAMETER (MM)	MAX. WORKING PRESSURE (BAR)	MAXIMUM FLUSHING PRESSURE (BAR)	KD
17012	14.60	1.20	17.00	4.0	5.2	1.10

DRIPPERLINES PACKAGE DATA (ON BUNDLED COILS)

MODEL	WALL THICKNESS (MM)	COIL LENGTH (M)	DISTANCE BETWEEN DRIPPERS (M)	AVERAGE* COIL WEIGHT (KG)	COILS IN A 40 FEET CONTAINER (UNITS)	TOTAL IN A 40 FEET CONTAINER (M)
17012	1.20	400	0.15 to 1.00	22.4	352	140800

*According to drippers spacing





DRIPNET PC™ TWD & MWD

COMPACT INTEGRAL PRESSURE-COMPENSATING,
CONTINUOUSLY SELF-CLEANING DRIPPER



12125 - 12150 - 12200 - 12250 - 16125 - 16150 - 16200
16250 - 22135 - 22150 - 22250 - 25135 - 25150 - 25250

APPLICATIONS

On-surface multi seasonal row crops.

FEATURES AND BENEFITS

- Pressure compensated: Precise and equal amounts of water are delivered over a broad pressure range. 100% uniformity of water and nutrient distribution along the laterals.
- Continuously self flushing: Continuously flushing debris, throughout operation, not just at the beginning or end of a cycle, ensuring uninterrupted dripper operation.
- Self-flushing system with wide filtration area improves resistance to clogging which allows reduction in filtration requirements, and increasing filtration efficiency.
- TurboNet™ labyrinth assures wide water passages, large deep and wide cross section improves clogging resistance. The water is drawn in to the dripper from the stream center, preventing the entrance of sediments in to the drippers.

SPECIFICATIONS

- Pressure-compensating range: 0.25/ 0.40/ 0.60-2.5/ 3.0/ 3.5 bar (according to flow rate model & dripperlines wall-thickness).
- Recommended filtration: according to drippers flow rate.
Filtration method is to be selected based on the kind and concentration of the dirt particles existing in the water. Wherever sand exceeding 2 ppm exists in the water, a Hydrocyclone is to be installed before the main filter. When sand/silt/ clay solids exceed 100 ppm, pre treatment will be applied according to Netafim™ expert team's instructions.
- TurboNet™ labyrinth with large water passage.
- A wide assortment of dripperlines wall thickness models (0.31, 0.34, 0.38, 0.50, 0.63 mm).
- Injected dripper, very low CV.
- Injected silicon diaphragm.
- High UV resistant. Resistant to standard nutrients used in agricultural.
- DripNet PC™ dripperlines meet ISO 9261 Standards with production certified by the Israel Standards Institute (SII).

DRIPPERS TECHNICAL DATA

FLOW RATE* (L/H)	WORKING PRESSURE RANGE (BAR)	WATER PASSAGES DIMENSIONS WIDTH-DEPTH-LENGTH (MM)	FILTRATION AREA (MM²)	CONSTANT K	EXPONENT* X	RECOMMENDED FILTRATION (MICRON)/(MESH)
0.4	0.25 - 2.5	0.46 × 0.52 × 26	29	0.4	0	130/120
0.6	0.25 - 2.5	0.52 × 0.60 × 22	39	0.6	0	130/120
1.0	0.40 - 3.0	0.61 × 0.60 × 8	39	1.0	0	130/120
1.6	0.40 - 3.0	0.76 × 0.73 × 8	39	1.6	0	200/80
2.0	0.40 - 3.5	0.84 × 0.80 × 8	39	2.0	0	200/80
3.0	0.40 - 3.5	1.02 × 0.88 × 8	39	3.0	0	200/80
3.8	0.60 - 3.5	1.02 × 0.88 × 8	39	3.8	0	200/80

* Within working pressure range

DRIPNET PC™ 12125

Catalog number **17200** - (any of below 6 digits)

FLOW RATE (L/H)	DISTANCE BETWEEN DRIPPERS (M)													
	0.15	0.20	0.25	0.30	0.35	0.40	0.50	0.60	0.65	0.70	0.75	0.80	0.90	1.00
0.4	000050	000070		000090										
0.6		001010		001390		001405	001450							
1.0	002850	003060		003220		003460	003480							
1.6		005010		005242		005410	005530							
2.0							006500							
3.0														
3.8														
Carton coil length (m)	1000	1100	1100	1200	1200	1200	1200	1200	1200	1200	1200	1200	1200	1200

Missing catalog numbers available upon request.

DRIPPERLINES TECHNICAL DATA

MODEL	INSIDE DIAMETER (MM)	WALL THICKNESS (MM)	OUTSIDE DIAMETER (MM)	MAX. WORKING PRESSURE (BAR)	MAXIMUM FLUSHING PRESSURE (BAR)	KD
12125	11.80	0.31	12.42	2.5	2.9	1.35

DRIPPERLINES PACKAGE DATA (ON CARTON COILS)

MODEL	WALL THICKNESS (MM)	DISTANCE BETWEEN DRIPPERS (M)	COIL LENGTH (M)	AVERAGE* COIL WEIGHT (KG)	COILS PER PALLET (UNITS)	COILS IN A 40 FEET CONTAINER (UNITS)	TOTAL IN A 40 FEET CONTAINER (M)
12125	0.31	0.15 to 0.19	1000	17.5	12	480	480000
		0.20 to 0.25	1100	16.3			528000
		0.30 to 1.00	1200	15.6			576000

*According to drippers spacing

DRIPNET PC™ 12150

Catalog number **17220** - (any of below 6 digits)

FLOW RATE (L/H)	DISTANCE BETWEEN DRIPPERS (M)													
	0.15	0.20	0.25	0.30	0.35	0.40	0.50	0.60	0.65	0.70	0.75	0.80	0.90	1.00
0.4						000370	000390							
0.6				001190		001410	001450							
1.0		003095	003150	003225		003430	003470							
1.6				005210		005390	005530							
2.0						006440	006500							
3.0				007700										
3.8														
Carton coil length (m)	800	900	900	900	900	900	900	900	900	900	900	900	900	900

Missing catalog numbers available upon request.

DRIPPERLINES TECHNICAL DATA

MODEL	INSIDE DIAMETER (MM)	WALL THICKNESS (MM)	OUTSIDE DIAMETER (MM)	MAX. WORKING PRESSURE (BAR)	MAXIMUM FLUSHING PRESSURE (BAR)	KD
12150	11.80	0.38	12.56	3.0	3.5	1.35

DRIPPERLINES PACKAGE DATA (ON CARTON COILS)

MODEL	WALL THICKNESS (MM)	DISTANCE BETWEEN DRIPPERS (M)	COIL LENGTH (M)	AVERAGE* COIL WEIGHT (KG)	COILS PER PALLET (UNITS)	COILS IN A 40 FEET CONTAINER (UNITS)	TOTAL IN A 40 FEET CONTAINER (M)
12150	0.38	0.15 to 0.19	800	14.8	12	480	384000
		0.20 to 0.35	900	14.5			432000
		0.40 to 1.00	900	14.0			432000

*According to drippers spacing

DRIPNET PCT™ 12200

Catalog number **17240** - (any of below 6 digits)

FLOW RATE (L/H)	DISTANCE BETWEEN DRIPPERS (M)													
	0.15	0.20	0.25	0.30	0.35	0.40	0.50	0.60	0.65	0.70	0.75	0.80	0.90	1.00
0.4														
0.6				001230		001430								
1.0				003240		003430								
1.6				005230		005385								
2.0	007010													
3.0														
3.8	008010													
Carton coil length (m)	750	850	850	850	850	850	850	850	850	850	850	850	850	850

Missing catalog numbers available upon request.

DRIPPERLINES TECHNICAL DATA

MODEL	INSIDE DIAMETER (MM)	WALL THICKNESS (MM)	OUTSIDE DIAMETER (MM)	MAX. WORKING PRESSURE (BAR)*	MAXIMUM FLUSHING PRESSURE (BAR)	KD
12200	11.80	0.50	12.80	3.0	3.9	1.35

*Maximum working pressure is defined by the dripper and not by the dripperline wall thickness

DRIPPERLINES PACKAGE DATA (ON CARTON COILS)

MODEL	WALL THICKNESS (MM)	DISTANCE BETWEEN DRIPPERS (M)	COIL LENGTH (M)	AVERAGE* COIL WEIGHT (KG)	COILS PER PALLET (UNITS)	COILS IN A 40 FEET CONTAINER (UNITS)	TOTAL IN A 40 FEET CONTAINER (M)
12200	0.50	0.15 to 0.19	750	17.1	12	480	360000
		0.20 to 0.35	850	17.4			408000
		0.40 to 1.00	850	16.9			408000

*According to drippers spacing

DRIPNET PCT™ 12250

Catalog number **17260** - (any of below 6 digits)

FLOW RATE (L/H)	DISTANCE BETWEEN DRIPPERS (M)													
	0.15	0.20	0.25	0.30	0.35	0.40	0.50	0.60	0.65	0.70	0.75	0.80	0.90	1.00
0.4														
0.6		001030		001210		001450	001530	001630						
1.0		003030		003230		003450	003550	003630				003850		
1.6		005030		005320		005440	005510	005630		005750				006050
2.0	006200					006460		006770		006800				007050
3.0						008050	008150							008750
3.8	009810							010050				010450		
Carton coil length (m)	650	700	700	800	800	800	800	800	800	800	800	800	800	800

Missing catalog numbers available upon request.

DRIPPERLINES TECHNICAL DATA

MODEL	INSIDE DIAMETER (MM)	WALL THICKNESS (MM)	OUTSIDE DIAMETER (MM)	MAX. WORKING PRESSURE (BAR)*	MAXIMUM FLUSHING PRESSURE (BAR)	KD
12250	11.80	0.63	13.06	3.0	3.9	1.35

*Maximum working pressure is defined by the dripper and not by the dripperline wall thickness

DRIPPERLINES PACKAGE DATA (ON CARTON COILS)

MODEL	WALL THICKNESS (MM)	DISTANCE BETWEEN DRIPPERS (M)	COIL LENGTH (M)	AVERAGE* COIL WEIGHT (KG)	COILS PER PALLET (UNITS)	COILS IN A 40 FEET CONTAINER (UNITS)	TOTAL IN A 40 FEET CONTAINER (M)
12250	0.63	0.15 to 0.19	650	19.5	12	480	312000
		0.20 to 0.25	700	20.4			336000
		0.30 to 1.00	800	19.1			384000

*According to drippers spacing

DRIPNET PC™ 16125

Catalog number **17600** - (any of below 6 digits)

FLOW RATE (L/H)	DISTANCE BETWEEN DRIPPERS (M)													
	0.15	0.20	0.25	0.30	0.35	0.40	0.50	0.60	0.65	0.70	0.75	0.80	0.90	1.00
0.4														
0.6		002300		008228		008305	008410	008480						
1.0		009870		010055	010185	010260	010455	010705			010730			
1.6		011980		012085		012260	012510	012560						
2.0				013910	013936	014010	014150							
3.0														
3.8														
Carton coil length (m)	1000	1150	1150	1150	1150	1300	1300	1300	1300	1300	1300	1300	1300	1300

Missing catalog numbers available upon request.

DRIPPERLINES TECHNICAL DATA

MODEL	INSIDE DIAMETER (MM)	WALL THICKNESS (MM)	OUTSIDE DIAMETER (MM)	MAX. WORKING PRESSURE (BAR)	MAXIMUM FLUSHING PRESSURE (BAR)	KD
16125	16.20	0.31	16.82	1.8	2.1	0.40

DRIPPERLINES PACKAGE DATA (ON CARTON COILS)

MODEL	WALL THICKNESS (MM)	DISTANCE BETWEEN DRIPPERS (M)	COIL LENGTH (M)	AVERAGE* COIL WEIGHT (KG)	COILS PER PALLET (UNITS)	COILS IN A 40 FEET CONTAINER (UNITS)	TOTAL IN A 40 FEET CONTAINER (M)
16125	0.31	0.15 to 0.19	1000	20.3	12	480	480000
		0.20 to 0.35	1150	21.3			552000
		0.40 to 1.00	1300	22.7			624000

*According to drippers spacing

DRIPNET PC™ 16150

Catalog number **17620** - (any of below 6 digits)

FLOW RATE (L/H)	DISTANCE BETWEEN DRIPPERS (M)													
	0.15	0.20	0.25	0.30	0.35	0.40	0.50	0.60	0.65	0.70	0.75	0.80	0.90	1.00
0.4				007290		007300	007320							
0.6	007650	007795	007830	007895	007940	008010	008210							
1.0		009890		010125	010060	010220	010340	010435		010450	010705	010717	010727	010737
1.6		012710		012860		013110	013330	013530	013546	013551	013600	013622	013854	013858
2.0				013887	013896		013960	013980			014110	014116	014121	014126
3.0						015110	015310	016160			016171	016181	016186	016191
3.8								018160						
Carton coil length (m)	950	1100	1100	1100	1100	1200	1200	1200	1200	1200	1200	1200	1200	1200

Missing catalog numbers available upon request.

DRIPPERLINES TECHNICAL DATA

MODEL	INSIDE DIAMETER (MM)	WALL THICKNESS (MM)	OUTSIDE DIAMETER (MM)	MAX. WORKING PRESSURE (BAR)	MAXIMUM FLUSHING PRESSURE (BAR)	KD
16150	16.20	0.38	16.96	2.2	2.5	0.40

DRIPPERLINES PACKAGE DATA (ON CARTON COILS)

MODEL	WALL THICKNESS (MM)	DISTANCE BETWEEN DRIPPERS (M)	COIL LENGTH (M)	AVERAGE* COIL WEIGHT (KG)	COILS PER PALLET (UNITS)	COILS IN A 40 FEET CONTAINER (UNITS)	TOTAL IN A 40 FEET CONTAINER (M)
16150	0.38	0.15 to 0.19	950	23.3	12	480	456000
		0.20 to 0.35	1100	24.2			528000
		0.40 to 1.00	1200	25.6			576000

*According to drippers spacing

DRIPNET PCT™ 16200

Catalog number **17630** - (any of below 6 digits)

FLOW RATE (L/H)	DISTANCE BETWEEN DRIPPERS (M)													
	0.15	0.20	0.25	0.30	0.35	0.40	0.50	0.60	0.65	0.70	0.75	0.80	0.90	1.00
0.4		000150												
0.6	001600	001700		001900		001920	002100							
1.0		004090		004120	004200		004350							
1.6	005850	005670				005750	005860							
2.0				007050		007070	007090							
3.0														
3.8														
Carton coil length (m)	750	800	800	800	800	850	850	850	850	850	850	850	850	850

Missing catalog numbers available upon request.

DRIPPERLINES TECHNICAL DATA

MODEL	INSIDE DIAMETER (MM)	WALL THICKNESS (MM)	OUTSIDE DIAMETER (MM)	MAX. WORKING PRESSURE (BAR)	MAXIMUM FLUSHING PRESSURE (BAR)	KD
16200	15.50	0.50	16.50	2.5	3.3	0.55

DRIPPERLINES PACKAGE DATA (ON CARTON COILS)

MODEL	WALL THICKNESS (MM)	DISTANCE BETWEEN DRIPPERS (M)	COIL LENGTH (M)	AVERAGE* COIL WEIGHT (KG)	COILS PER PALLET (UNITS)	COILS IN A 40 FEET CONTAINER (UNITS)	TOTAL IN A 40 FEET CONTAINER (M)
16200	0.50	0.15 to 0.19	750	19.9	12	480	360000
		0.20 to 0.35	800	19.6			384000
		0.40 to 1.00	850	19.1			408000

*According to drippers spacing

DRIPNET PCT™ 16250

Catalog number **17640** - (any of below 6 digits)

FLOW RATE (L/H)	DISTANCE BETWEEN DRIPPERS (M)													
	0.15	0.20	0.25	0.30	0.35	0.40	0.50	0.60	0.65	0.70	0.75	0.80	0.90	1.00
0.4														
0.6			001300	001360		001430	001500	002000		002100		002200		002230
1.0		003850	004020	004240	004260	004460	004640	004820	004870	005050	005080	005090	005150	005250
1.6	006550	006750	006850	007100	007140	007252	007355	007450	007550	007900	008055	008150	008200	008300
2.0		008570	008610	008617	008630	008700	008740	008790	008840	008900	009000	009100		009230
3.0		009900	010270	010300	010320	010400	010500	010650	010670	010740	010850	010900		012100
3.8		013275	013285	013295		013300	013500	013600		013660	013700	013702		013900
Carton coil length (m)	750	800	800	800	800	800	800	800	800	800	800	800	800	800

Missing catalog numbers available upon request.

DRIPPERLINES TECHNICAL DATA

MODEL	INSIDE DIAMETER (MM)	WALL THICKNESS (MM)	OUTSIDE DIAMETER (MM)	MAX. WORKING PRESSURE (BAR)	MAXIMUM FLUSHING PRESSURE (BAR)	KD
16250	15.50	0.63	16.76	2.8	3.6	0.55

DRIPPERLINES PACKAGE DATA (ON CARTON COILS)

MODEL	WALL THICKNESS (MM)	DISTANCE BETWEEN DRIPPERS (M)	COIL LENGTH (M)	AVERAGE* COIL WEIGHT (KG)	COILS PER PALLET (UNITS)	COILS IN A 40 FEET CONTAINER (UNITS)	TOTAL IN A 40 FEET CONTAINER (M)
16250	0.63	0.15 to 0.19	750	26.5	12	480	360000
		0.20 to 0.35	800	26.9			384000
		0.40 to 1.00	800	26.1			384000

*According to drippers spacing

DRIPNET PC™ 22135

Catalog number **17740** - (any of below 6 digits)

FLOW RATE (L/H)	DISTANCE BETWEEN DRIPPERS (M)													
	0.15	0.20	0.25	0.30	0.35	0.40	0.50	0.60	0.65	0.70	0.75	0.80	0.90	1.00
0.6				002160		008210	008420	008470						
1.0				008600		008620	008650	008670						
1.6				010940		011010								
2.0											013020			
3.0														
3.8														
Carton coil length (m)	800	850	850	850	850	950	950	950	950	950	950	950	950	950

Missing catalog numbers available upon request.

DRIPPERLINES TECHNICAL DATA

MODEL	INSIDE DIAMETER (MM)	WALL THICKNESS (MM)	OUTSIDE DIAMETER (MM)	MAX. WORKING PRESSURE (BAR)	MAXIMUM FLUSHING PRESSURE (BAR)	KD
22135	22.20	0.34	22.88	1.5	1.7	0.18

DRIPPERLINES PACKAGE DATA (ON CARTON COILS)

MODEL	WALL THICKNESS (MM)	DISTANCE BETWEEN DRIPPERS (M)	COIL LENGTH (M)	AVERAGE* COIL WEIGHT (KG)	COILS PER PALLET (UNITS)	COILS IN A 40 FEET CONTAINER (UNITS)	TOTAL IN A 40 FEET CONTAINER (M)
22135	0.34	0.15 to 0.19	800	23.5	12	480	384000
		0.20 to 0.35	850	22.9			408000
		0.40 to 1.00	950	24.5			456000

*According to drippers spacing

DRIPNET PC™ 22150

Catalog number **17760** - (any of below 6 digits)

FLOW RATE (L/H)	DISTANCE BETWEEN DRIPPERS (M)													
	0.15	0.20	0.25	0.30	0.35	0.40	0.50	0.60	0.65	0.70	0.75	0.80	0.90	1.00
0.6				008290		001710								
1.0				010110		010130	010150							
1.6		011900				012010								
2.0							013500							
3.0							014500							
3.8														
Carton coil length (m)	700	800	800	800	800	850	850	850	850	850	850	850	850	850

Missing catalog numbers available upon request.

DRIPPERLINES TECHNICAL DATA

MODEL	INSIDE DIAMETER (MM)	WALL THICKNESS (MM)	OUTSIDE DIAMETER (MM)	MAX. WORKING PRESSURE (BAR)	MAXIMUM FLUSHING PRESSURE (BAR)	KD
22150	22.20	0.38	22.96	1.8	2.1	0.18

DRIPPERLINES PACKAGE DATA (ON CARTON COILS)

MODEL	WALL THICKNESS (MM)	DISTANCE BETWEEN DRIPPERS (M)	COIL LENGTH (M)	AVERAGE* COIL WEIGHT (KG)	COILS PER PALLET (UNITS)	COILS IN A 40 FEET CONTAINER (UNITS)	TOTAL IN A 40 FEET CONTAINER (M)
22150	0.38	0.15 to 0.19	700	22.6	12	480	336000
		0.20 to 0.35	800	23.8			384000
		0.40 to 1.00	850	24.4			408000

*According to drippers spacing

DRIPNET PC™ 22250

Catalog number **17780** - (any of below 6 digits)

FLOW RATE (L/H)	DISTANCE BETWEEN DRIPPERS (M)													
	0.15	0.20	0.25	0.30	0.35	0.40	0.50	0.60	0.65	0.70	0.75	0.80	0.90	1.00
0.6			001100	001240		001365	001600							
1.0				002600		002800	003000	003130						003750
1.6				004100		004300	004500					004850		
2.0														
3.0							006500							
3.8														
Carton coil length (m)	450	500	500	500	500	500	500	500	500	500	500	500	500	500

Missing catalog numbers available upon request.

DRIPPERLINES TECHNICAL DATA

MODEL	INSIDE DIAMETER (MM)	WALL THICKNESS (MM)	OUTSIDE DIAMETER (MM)	MAX. WORKING PRESSURE (BAR)	MAXIMUM FLUSHING PRESSURE (BAR)	KD
22250	22.20	0.63	23.46	2.5	2.9	0.18

DRIPPERLINES PACKAGE DATA (ON CARTON COILS)

MODEL	WALL THICKNESS (MM)	DISTANCE BETWEEN DRIPPERS (M)	COIL LENGTH (M)	AVERAGE* COIL WEIGHT (KG)	COILS PER PALLET (UNITS)	COILS IN A 40 FEET CONTAINER (UNITS)	TOTAL IN A 40 FEET CONTAINER (M)
22250	0.63	0.15 to 0.19	450	26.6	12	480	216000
		0.20 to 0.35	500	28.0			240000
		0.40 to 1.00	500	27.4			240000

*According to drippers spacing

DRIPNET PC™ 25135

Catalog number **17810** - (any of below 6 digits)

FLOW RATE (L/H)	DISTANCE BETWEEN DRIPPERS (M)													
	0.15	0.20	0.25	0.30	0.35	0.40	0.50	0.60	0.65	0.70	0.75	0.80	0.90	1.00
0.6						001800	002000							
1.0						003800	004000							
1.6														
2.0														
3.0														
3.8														
Carton coil length (m)	650	800	800	800	800	800	800	800	800	800	800	800	800	800

Missing catalog numbers available upon request.

DRIPPERLINES TECHNICAL DATA

MODEL	INSIDE DIAMETER (MM)	WALL THICKNESS (MM)	OUTSIDE DIAMETER (MM)	MAX. WORKING PRESSURE (BAR)	MAXIMUM FLUSHING PRESSURE (BAR)	KD
25135	25.00	0.34	25.68	1.2	1.4	0.04

DRIPPERLINES PACKAGE DATA (ON CARTON COILS)

MODEL	WALL THICKNESS (MM)	DISTANCE BETWEEN DRIPPERS (M)	COIL LENGTH (M)	AVERAGE* COIL WEIGHT (KG)	COILS PER PALLET (UNITS)	COILS IN A 40 FEET CONTAINER (UNITS)	TOTAL IN A 40 FEET CONTAINER (M)
25135	0.34	0.15 to 0.19	650	19.3	12	480	312000
		0.20 to 0.35	800	20.0			384000
		0.40 to 1.00	800	20.9			384000

*According to drippers spacing

DRIPNET PC™ 25150

Catalog number **17820** - (any of below 6 digits)

FLOW RATE (L/H)	DISTANCE BETWEEN DRIPPERS (M)													
	0.15	0.20	0.25	0.30	0.35	0.40	0.50	0.60	0.65	0.70	0.75	0.80	0.90	1.00
0.6						001550	001750							
1.0														
1.6														
2.0														
3.0														
3.8														
Carton coil length (m)	550	700	700	700	700	700	700	700	700	700	700	700	700	700

Missing catalog numbers available upon request.

DRIPPERLINES TECHNICAL DATA

MODEL	INSIDE DIAMETER (MM)	WALL THICKNESS (MM)	OUTSIDE DIAMETER (MM)	MAX. WORKING PRESSURE (BAR)	MAXIMUM FLUSHING PRESSURE (BAR)	KD
25150	25.00	0.38	25.76	1.4	1.6	0.04

DRIPPERLINES PACKAGE DATA (ON CARTON COILS)

MODEL	WALL THICKNESS (MM)	DISTANCE BETWEEN DRIPPERS (M)	COIL LENGTH (M)	AVERAGE* COIL WEIGHT (KG)	COILS PER PALLET (UNITS)	COILS IN A 40 FEET CONTAINER (UNITS)	TOTAL IN A 40 FEET CONTAINER (M)
25150	0.38	0.15 to 0.19	550	19.4	12	480	264000
		0.20 to 0.35	700	20.0			336000
		0.40 to 1.00	700	22.2			336000

*According to drippers spacing

DRIPNET PC™ 25250

Catalog number **17840** - (any of below 6 digits)

FLOW RATE (L/H)	DISTANCE BETWEEN DRIPPERS (M)													
	0.15	0.20	0.25	0.30	0.35	0.40	0.50	0.60	0.65	0.70	0.75	0.80	0.90	1.00
0.6						001600								
1.0						002800	003000							
1.6						004800	005000							
2.0														
3.0														
3.8														
Carton coil length (m)	450	500	500	500	500	500	500	500	500	500	500	500	500	500

Missing catalog numbers available upon request.

DRIPPERLINES TECHNICAL DATA

MODEL	INSIDE DIAMETER (MM)	WALL THICKNESS (MM)	OUTSIDE DIAMETER (MM)	MAX. WORKING PRESSURE (BAR)	MAXIMUM FLUSHING PRESSURE (BAR)	KD
25250	25.00	0.63	26.26	2.0	2.3	0.04

DRIPPERLINES PACKAGE DATA (ON CARTON COILS)

MODEL	WALL THICKNESS (MM)	DISTANCE BETWEEN DRIPPERS (M)	COIL LENGTH (M)	AVERAGE* COIL WEIGHT (KG)	COILS PER PALLET (UNITS)	COILS IN A 40 FEET CONTAINER (UNITS)	TOTAL IN A 40 FEET CONTAINER (M)
25250	0.63	0.15 to 0.19	450	24.4	12	480	216000
		0.20 to 0.35	500	26.2			240000
		0.40 to 1.00	500	25.4			240000

*According to drippers spacing



DRIPNET PC™ AS TWD & MWD

COMPACT INTEGRAL PRESSURE-COMPENSATING,
CONTINUOUSLY SELF-CLEANING, ANTI-SIPHON
MECHANISM DRIPPER



12125 - 12150 - 12200 - 12250 - 16125 - 16150 - 16200
16250 - 22135 - 22150 - 22250 - 25135 - 25150 - 25250

APPLICATIONS

Sub-surface multi seasonal row crops.

FEATURES AND BENEFITS

- Pressure compensated: Precise and equal amounts of water are delivered over a broad pressure range. 100% uniformity of water and nutrient distribution along the laterals.
- Anti-Siphon mechanism: Prevents contaminants from being drawn into the dripper, which is needed in sub surface applications.
- Continuously self flushing: Continuously flushing debris, throughout operation, not just at the beginning or end of a cycle, ensuring uninterrupted dripper operation.
- Self-flushing system with wide filtration area improves resistance to clogging this allows reduction in filtration requirements, and increase filtration efficiency.
- TurboNet™ labyrinth assures wide water passages, large deep and wide cross section improves clogging resistance.
- The water is drawn in to the dripper from the stream center, preventing the entrance of sediments in to the drippers.

SPECIFICATIONS

- Pressure-compensating range: 0.25/ 0.40/ 0.60-2.5/ 3.0/ 3.5 bar (according to flow rate model & dripperlines wall-thickness).
- Anti-Siphon mechanism.
- Recommended filtration: according to drippers flow rate.
Filtration method is to be selected based on the kind and concentration of the dirt particles existing in the water. Wherever sand exceeding 2 ppm exists in the water, a Hydrocyclone is to be installed before the main filter. When sand/ silt/ clay solids exceed 100 ppm, pre treatment will be applied according to Netafim™ expert team's instructions.
- TurboNet™ labyrinth with large water passage.
- A wide assortment of dripperlines wall thickness models (0.31, 0.34, 0.38, 0.50, 0.63 mm).
- Injected dripper, very low CV.
- Injected silicon diaphragm.
- High UV resistant. Resistant to standard nutrients used in agricultural.
- DripNet PC™ dripperlines meet ISO 9261 Standards with production certified by the Israel Standards Institute (SII).

DRIPPERS TECHNICAL DATA

FLOW RATE* (L/H)	WORKING PRESSURE RANGE (BAR)	WATER PASSAGES DIMENSIONS WIDTH-DEPTH-LENGTH (MM)	FILTRATION AREA (MM ²)	CONSTANT K	EXPONENT* X	RECOMMENDED FILTRATION (MICRON)/(MESH)
0.6	0.25 - 2.5	0.52 x 0.60 x 22	42	0.6	0	130/120
1.0	0.40 - 3.0	0.61 x 0.60 x 8	42	1.0	0	130/120
1.6	0.40 - 3.0	0.76 x 0.73 x 8	42	1.6	0	200/80
2.0	0.40 - 3.5	0.84 x 0.80 x 8	42	2.0	0	200/80
3.0	0.40 - 3.5	1.02 x 0.88 x 8	42	3.0	0	200/80
3.8	0.60 - 3.5	1.02 x 0.88 x 8	42	3.8	0	200/80

* Within working pressure range

DRIPNET PC™ AS 12125

Catalog number **17210** - (any of below 6 digits)

FLOW RATE (L/H)	DISTANCE BETWEEN DRIPPERS (M)													
	0.15	0.20	0.25	0.30	0.35	0.40	0.50	0.60	0.65	0.70	0.75	0.80	0.90	1.00
0.6		001311		001370		001470								
1.0				002470		002570								
1.6				003470		003570								
2.0														
3.0														
3.8														
Carton coil length (m)	900	1000	1000	1000	1000	1000	1000	1000	1000	1000	1000	1000	1000	1000

Missing catalog numbers available upon request.

DRIPPERLINES TECHNICAL DATA

MODEL	INSIDE DIAMETER (MM)	WALL THICKNESS (MM)	OUTSIDE DIAMETER (MM)	MAX. WORKING PRESSURE (BAR)	MAXIMUM FLUSHING PRESSURE (BAR)	KD
12125	11.80	0.31	12.42	2.5	2.9	1.35

DRIPPERLINES PACKAGE DATA (ON CARTON COILS)

MODEL	WALL THICKNESS (MM)	DISTANCE BETWEEN DRIPPERS (M)	COIL LENGTH (M)	AVERAGE* COIL WEIGHT (KG)	COILS PER PALLET (UNITS)	COILS IN A 40 FEET CONTAINER (UNITS)	TOTAL IN A 40 FEET CONTAINER (M)
12125	0.31	0.15 to 0.19	900	14.3	12	480	432000
		0.20 to 0.35	1000	13.6			480000
		0.40 to 1.00	1000	13.0			480000

*According to drippers spacing

DRIPNET PC™ AS 12150

Catalog number **17225** - (any of below 6 digits)

FLOW RATE (L/H)	DISTANCE BETWEEN DRIPPERS (M)													
	0.15	0.20	0.25	0.30	0.35	0.40	0.50	0.60	0.65	0.70	0.75	0.80	0.90	1.00
0.6			001300	001370		001470	000001							
1.0				002470		002570								
1.6				003470		003570								
2.0						004610								
3.0														
3.8														
Carton coil length (m)	600	700	700	700	700	700	700	700	700	700	700	700	700	700

Missing catalog numbers available upon request.

DRIPPERLINES TECHNICAL DATA

MODEL	INSIDE DIAMETER (MM)	WALL THICKNESS (MM)	OUTSIDE DIAMETER (MM)	MAX. WORKING PRESSURE (BAR)	MAXIMUM FLUSHING PRESSURE (BAR)	KD
12150	11.80	0.38	12.56	3.0	3.5	1.35

DRIPPERLINES PACKAGE DATA (ON CARTON COILS)

MODEL	WALL THICKNESS (MM)	DISTANCE BETWEEN DRIPPERS (M)	COIL LENGTH (M)	AVERAGE* COIL WEIGHT (KG)	COILS PER PALLET (UNITS)	COILS IN A 40 FEET CONTAINER (UNITS)	TOTAL IN A 40 FEET CONTAINER (M)
12150	0.38	0.15 to 0.19	600	11.1	12	480	288000
		0.20 to 0.35	700	11.3			336000
		0.40 to 1.00	700	10.9			336000

*According to drippers spacing

DRIPNET PCT™ AS 12200

Catalog number **17245** - (any of below 6 digits)

FLOW RATE (L/H)	DISTANCE BETWEEN DRIPPERS (M)													
	0.15	0.20	0.25	0.30	0.35	0.40	0.50	0.60	0.65	0.70	0.75	0.80	0.90	1.00
0.6				001370		001470								
1.0				002470		002570								
1.6				003470		003570								
2.0														
3.0														
3.8														
Carton coil length (m)	650	750	750	750	750	850	850	850	850	850	850	850	850	850

Missing catalog numbers available upon request.

DRIPPERLINES TECHNICAL DATA

MODEL	INSIDE DIAMETER (MM)	WALL THICKNESS (MM)	OUTSIDE DIAMETER (MM)	MAX. WORKING PRESSURE (BAR)*	MAXIMUM FLUSHING PRESSURE (BAR)	KD
12200	11.80	0.50	12.80	3.0	3.9	1.35

*Maximum working pressure is defined by the dripper and not by the dripperline wall thickness

DRIPPERLINES PACKAGE DATA (ON CARTON COILS)

MODEL	WALL THICKNESS (MM)	DISTANCE BETWEEN DRIPPERS (M)	COIL LENGTH (M)	AVERAGE* COIL WEIGHT (KG)	COILS PER PALLET (UNITS)	COILS IN A 40 FEET CONTAINER (UNITS)	TOTAL IN A 40 FEET CONTAINER (M)
12200	0.50	0.15 to 0.19	650	14.9	12	480	312000
		0.20 to 0.35	750	15.4			360000
		0.40 to 1.00	850	17.4			408000

*According to drippers spacing

DRIPNET PCT™ AS 12250

Catalog number **17270** - (any of below 6 digits)

FLOW RATE (L/H)	DISTANCE BETWEEN DRIPPERS (M)													
	0.15	0.20	0.25	0.30	0.35	0.40	0.50	0.60	0.65	0.70	0.75	0.80	0.90	1.00
0.6			001400	001520		001630								
1.0	002740		002820	002920		003030								
1.6				004100		004220	004350					005100		
2.0														
3.0														
3.8														
Carton coil length (m)	600	700	700	700	700	800	800	800	800	800	800	800	800	800

Missing catalog numbers available upon request.

DRIPPERLINES TECHNICAL DATA

MODEL	INSIDE DIAMETER (MM)	WALL THICKNESS (MM)	OUTSIDE DIAMETER (MM)	MAX. WORKING PRESSURE (BAR)*	MAXIMUM FLUSHING PRESSURE (BAR)	KD
12250	11.80	0.63	13.06	3.0	3.9	1.35

*Maximum working pressure is defined by the dripper and not by the dripperline wall thickness

DRIPPERLINES PACKAGE DATA (ON CARTON COILS)

MODEL	WALL THICKNESS (MM)	DISTANCE BETWEEN DRIPPERS (M)	COIL LENGTH (M)	AVERAGE* COIL WEIGHT (KG)	COILS PER PALLET (UNITS)	COILS IN A 40 FEET CONTAINER (UNITS)	TOTAL IN A 40 FEET CONTAINER (M)
12250	0.63	0.15 to 0.19	600	16.7	12	480	288000
		0.20 to 0.35	700	17.8			336000
		0.40 to 1.00	800	19.9			384000

*According to drippers spacing

DRIPNET PC™ AS 16125

Catalog number **17610** - (any of below 6 digits)

FLOW RATE (L/H)	DISTANCE BETWEEN DRIPPERS (M)													
	0.15	0.20	0.25	0.30	0.35	0.40	0.50	0.60	0.65	0.70	0.75	0.80	0.90	1.00
0.6		000001		000470		000510	000720	000820						
1.0		001579		001671		001815	001915	002020						
1.6				003530		003620	003720							
2.0														
3.0														
3.8														
Carton coil length (m)	1000	1150	1150	1150	1150	1300	1300	1300	1300	1300	1300	1300	1300	1300

Missing catalog numbers available upon request.

DRIPPERLINES TECHNICAL DATA

MODEL	INSIDE DIAMETER (MM)	WALL THICKNESS (MM)	OUTSIDE DIAMETER (MM)	MAX. WORKING PRESSURE (BAR)	MAXIMUM FLUSHING PRESSURE (BAR)	KD
16125	16.20	0.31	16.82	1.8	2.1	0.40

DRIPPERLINES PACKAGE DATA (ON CARTON COILS)

MODEL	WALL THICKNESS (MM)	DISTANCE BETWEEN DRIPPERS (M)	COIL LENGTH (M)	AVERAGE* COIL WEIGHT (KG)	COILS PER PALLET (UNITS)	COILS IN A 40 FEET CONTAINER (UNITS)	TOTAL IN A 40 FEET CONTAINER (M)
16125	0.31	0.15 to 0.19	1000	20.3	12	480	480000
		0.20 to 0.35	1150	21.3			552000
		0.40 to 1.00	1300	22.7			624000

*According to drippers spacing

DRIPNET PC™ AS 16150

Catalog number **17615** - (any of below 6 digits)

FLOW RATE (L/H)	DISTANCE BETWEEN DRIPPERS (M)													
	0.15	0.20	0.25	0.30	0.35	0.40	0.50	0.60	0.65	0.70	0.75	0.80	0.90	1.00
0.6		000470	000495	000580		000634	000672	000697			000699			
1.0	001370	001470	001482	001600	001580	001825	002015	002120	002210	002360	002370	000003		002430
1.6		004320		004380	004520	004645	004820	004920	005020		005120	005130		
2.0		007170		007360		007451	007625							
3.0						007460								
3.8														
Carton coil length (m)	900	1000	1000	1000	1000	1200	1200	1200	1200	1200	1200	1200	1200	1200

Missing catalog numbers available upon request.

DRIPPERLINES TECHNICAL DATA

MODEL	INSIDE DIAMETER (MM)	WALL THICKNESS (MM)	OUTSIDE DIAMETER (MM)	MAX. WORKING PRESSURE (BAR)	MAXIMUM FLUSHING PRESSURE (BAR)	KD
16150	16.20	0.38	16.96	2.2	2.5	0.40

DRIPPERLINES PACKAGE DATA (ON CARTON COILS)

MODEL	WALL THICKNESS (MM)	DISTANCE BETWEEN DRIPPERS (M)	COIL LENGTH (M)	AVERAGE* COIL WEIGHT (KG)	COILS PER PALLET (UNITS)	COILS IN A 40 FEET CONTAINER (UNITS)	TOTAL IN A 40 FEET CONTAINER (M)
16150	0.38	0.15 to 0.19	900	21.2	12	480	432000
		0.20 to 0.35	1000	21.1			480000
		0.40 to 1.00	1200	25.6			576000

*According to drippers spacing

DRIPNET PC™ AS 16200

Catalog number **17635** - (any of below 6 digits)

FLOW RATE (L/H)	DISTANCE BETWEEN DRIPPERS (M)													
	0.15	0.20	0.25	0.30	0.35	0.40	0.50	0.60	0.65	0.70	0.75	0.80	0.90	1.00
0.6	001050	001110		001250										
1.0				002400		002600								
1.6								004550						
2.0														
3.0														
3.8														
Carton coil length (m)	750	800	800	800	800	850	850	850	850	850	850	850	850	850

Missing catalog numbers available upon request.

DRIPPERLINES TECHNICAL DATA

MODEL	INSIDE DIAMETER (MM)	WALL THICKNESS (MM)	OUTSIDE DIAMETER (MM)	MAX. WORKING PRESSURE (BAR)	MAXIMUM FLUSHING PRESSURE (BAR)	KD
16200	15.50	0.50	16.50	2.5	3.3	0.55

DRIPPERLINES PACKAGE DATA (ON CARTON COILS)

MODEL	WALL THICKNESS (MM)	DISTANCE BETWEEN DRIPPERS (M)	COIL LENGTH (M)	AVERAGE* COIL WEIGHT (KG)	COILS PER PALLET (UNITS)	COILS IN A 40 FEET CONTAINER (UNITS)	TOTAL IN A 40 FEET CONTAINER (M)
16200	0.50	0.15 to 0.19	750	19.9	12	480	360000
		0.20 to 0.35	800	19.6			384000
		0.40 to 1.00	850	19.1			408000

*According to drippers spacing

DRIPNET PC™ AS 16250

Catalog number **17645** - (any of below 6 digits)

FLOW RATE (L/H)	DISTANCE BETWEEN DRIPPERS (M)													
	0.15	0.20	0.25	0.30	0.35	0.40	0.50	0.60	0.65	0.70	0.75	0.80	0.90	1.00
0.6				001300		001400	001500	001600	001605	001607	001620			
1.0	002490	002535	002540	002600	002650	002800	003100	003200	003250	003280	003300	003320		003350
1.6				004400	004500	004600	004800	005000	005100	005200	005300	005400	000005	
2.0	005990			006050		006060	006100	006250	006260	006352	006365	000004		000003
3.0				007000		007200	007400	007600	007620	007642	007700	007800		
3.8							009000							
Carton coil length (m)	700	800	800	800	800	800	800	800	800	800	800	800	800	800

Missing catalog numbers available upon request.

DRIPPERLINES TECHNICAL DATA

MODEL	INSIDE DIAMETER (MM)	WALL THICKNESS (MM)	OUTSIDE DIAMETER (MM)	MAX. WORKING PRESSURE (BAR)	MAXIMUM FLUSHING PRESSURE (BAR)	KD
16250	15.50	0.63	16.76	2.8	3.6	0.55

DRIPPERLINES PACKAGE DATA (ON CARTON COILS)

MODEL	WALL THICKNESS (MM)	DISTANCE BETWEEN DRIPPERS (M)	COIL LENGTH (M)	AVERAGE* COIL WEIGHT (KG)	COILS PER PALLET (UNITS)	COILS IN A 40 FEET CONTAINER (UNITS)	TOTAL IN A 40 FEET CONTAINER (M)
16250	0.63	0.15 to 0.19	700	26.5	12	480	336000
		0.20 to 0.35	800	26.9			384000
		0.40 to 1.00	800	26.1			384000

*According to drippers spacing

DRIPNET PC™ AS 22135

Catalog number **17745** - (any of below 6 digits)

FLOW RATE (L/H)	DISTANCE BETWEEN DRIPPERS (M)													
	0.15	0.20	0.25	0.30	0.35	0.40	0.50	0.60	0.65	0.70	0.75	0.80	0.90	1.00
0.6		001200		001310		001440								
1.0				002440		002550	002750	002850						
1.6				004540		004650	004950							
2.0							006300							
3.0														
3.8														
Carton coil length (m)	750	800	800	800	800	950	950	950	950	950	950	950	950	950

Missing catalog numbers available upon request.

DRIPPERLINES TECHNICAL DATA

MODEL	INSIDE DIAMETER (MM)	WALL THICKNESS (MM)	OUTSIDE DIAMETER (MM)	MAX. WORKING PRESSURE (BAR)	MAXIMUM FLUSHING PRESSURE (BAR)	KD
22135	22.20	0.34	22.88	1.5	1.7	0.18

DRIPPERLINES PACKAGE DATA (ON CARTON COILS)

MODEL	WALL THICKNESS (MM)	DISTANCE BETWEEN DRIPPERS (M)	COIL LENGTH (M)	AVERAGE* COIL WEIGHT (KG)	COILS PER PALLET (UNITS)	COILS IN A 40 FEET CONTAINER (UNITS)	TOTAL IN A 40 FEET CONTAINER (M)
22135	0.34	0.15 to 0.19	750	22.1	12	480	360000
		0.20 to 0.35	800	21.6			384000
		0.40 to 1.00	950	24.5			456000

*According to drippers spacing

DRIPNET PC™ AS 22150

Catalog number **17770** - (any of below 6 digits)

FLOW RATE (L/H)	DISTANCE BETWEEN DRIPPERS (M)													
	0.15	0.20	0.25	0.30	0.35	0.40	0.50	0.60	0.65	0.70	0.75	0.80	0.90	1.00
0.6		001470	001600			001850	002050	002070						
1.0		003740		003750	003755	003850	004020	004150						
1.6		004900		004950		005070	005170	005250						
2.0							006170							
3.0														
3.8														
Carton coil length (m)	650	750	750	750	750	850	850	850	850	850	850	850	850	850

Missing catalog numbers available upon request.

DRIPPERLINES TECHNICAL DATA

MODEL	INSIDE DIAMETER (MM)	WALL THICKNESS (MM)	OUTSIDE DIAMETER (MM)	MAX. WORKING PRESSURE (BAR)	MAXIMUM FLUSHING PRESSURE (BAR)	KD
22150	22.20	0.38	22.96	1.8	2.1	0.18

DRIPPERLINES PACKAGE DATA (ON CARTON COILS)

MODEL	WALL THICKNESS (MM)	DISTANCE BETWEEN DRIPPERS (M)	COIL LENGTH (M)	AVERAGE* COIL WEIGHT (KG)	COILS PER PALLET (UNITS)	COILS IN A 40 FEET CONTAINER (UNITS)	TOTAL IN A 40 FEET CONTAINER (M)
22150	0.38	0.15 to 0.19	650	21.1	12	480	312000
		0.20 to 0.35	750	22.4			360000
		0.40 to 1.00	850	24.4			408000

*According to drippers spacing

DRIPNET PC™ AS 22250

Catalog number **17790** - (any of below 6 digits)

FLOW RATE (L/H)	DISTANCE BETWEEN DRIPPERS (M)													
	0.15	0.20	0.25	0.30	0.35	0.40	0.50	0.60	0.65	0.70	0.75	0.80	0.90	1.00
0.6				001700		001800	002000							
1.0				003650		003800	004000	004040						
1.6		004850		004870		004950	005050							
2.0							006050							
3.0			007500											
3.8														
Carton coil length (m)	450	500	500	500	500	500	500	500	500	500	500	500	500	500

Missing catalog numbers available upon request.

DRIPPERLINES TECHNICAL DATA

MODEL	INSIDE DIAMETER (MM)	WALL THICKNESS (MM)	OUTSIDE DIAMETER (MM)	MAX. WORKING PRESSURE (BAR)	MAXIMUM FLUSHING PRESSURE (BAR)	KD
22250	22.20	0.63	23.46	2.5	2.9	0.18

DRIPPERLINES PACKAGE DATA (ON CARTON COILS)

MODEL	WALL THICKNESS (MM)	DISTANCE BETWEEN DRIPPERS (M)	COIL LENGTH (M)	AVERAGE* COIL WEIGHT (KG)	COILS PER PALLET (UNITS)	COILS IN A 40 FEET CONTAINER (UNITS)	TOTAL IN A 40 FEET CONTAINER (M)
22250	0.63	0.15 to 0.19	450	26.6	12	480	216000
		0.20 to 0.35	500	28.0			240000
		0.40 to 1.00	500	27.4			240000

*According to drippers spacing

DRIPNET PC™ AS 25135

Catalog number **17815** - (any of below 6 digits)

FLOW RATE (L/H)	DISTANCE BETWEEN DRIPPERS (M)													
	0.15	0.20	0.25	0.30	0.35	0.40	0.50	0.60	0.65	0.70	0.75	0.80	0.90	1.00
0.6				001500		001600								
1.0						002600								
1.6														
2.0														
3.0														
3.8														
Carton coil length (m)	550	700	700	700	700	700	700	700	700	700	700	700	700	700

Missing catalog numbers available upon request.

DRIPPERLINES TECHNICAL DATA

MODEL	INSIDE DIAMETER (MM)	WALL THICKNESS (MM)	OUTSIDE DIAMETER (MM)	MAX. WORKING PRESSURE (BAR)	MAXIMUM FLUSHING PRESSURE (BAR)	KD
25135	25.00	0.34	25.68	1.2	1.4	0.04

DRIPPERLINES PACKAGE DATA (ON CARTON COILS)

MODEL	WALL THICKNESS (MM)	DISTANCE BETWEEN DRIPPERS (M)	COIL LENGTH (M)	AVERAGE* COIL WEIGHT (KG)	COILS PER PALLET (UNITS)	COILS IN A 40 FEET CONTAINER (UNITS)	TOTAL IN A 40 FEET CONTAINER (M)
25135	0.34	0.15 to 0.19	550	16.7	12	480	264000
		0.20 to 0.35	700	19.6			336000
		0.40 to 1.00	700	19.2			336000

*According to drippers spacing

DRIPNET PC™ AS 25150

Catalog number **17819** - (any of below 6 digits)

FLOW RATE (L/H)	DISTANCE BETWEEN DRIPPERS (M)													
	0.15	0.20	0.25	0.30	0.35	0.40	0.50	0.60	0.65	0.70	0.75	0.80	0.90	1.00
0.6														
1.0							002000							
1.6														
2.0														
3.0														
3.8														
Carton coil length (m)	450	600	600	600	600	600	600	600	600	600	600	600	600	600

Missing catalog numbers available upon request.

DRIPPERLINES TECHNICAL DATA

MODEL	INSIDE DIAMETER (MM)	WALL THICKNESS (MM)	OUTSIDE DIAMETER (MM)	MAX. WORKING PRESSURE (BAR)	MAXIMUM FLUSHING PRESSURE (BAR)	KD
25150	25.00	0.38	25.76	1.4	1.6	0.04

DRIPPERLINES PACKAGE DATA (ON CARTON COILS)

MODEL	WALL THICKNESS (MM)	DISTANCE BETWEEN DRIPPERS (M)	COIL LENGTH (M)	AVERAGE* COIL WEIGHT (KG)	COILS PER PALLET (UNITS)	COILS IN A 40 FEET CONTAINER (UNITS)	TOTAL IN A 40 FEET CONTAINER (M)
25150	0.38	0.15 to 0.19	450	15.0	12	480	216000
		0.20 to 0.35	600	18.7			288000
		0.40 to 1.00	600	18.3			288000

*According to drippers spacing

DRIPNET PC™ AS 25250

Catalog number **17850** - (any of below 6 digits)

FLOW RATE (L/H)	DISTANCE BETWEEN DRIPPERS (M)													
	0.15	0.20	0.25	0.30	0.35	0.40	0.50	0.60	0.65	0.70	0.75	0.80	0.90	1.00
0.6				001600			001720	001800						
1.0				002500		002700	002850							
1.6							003850	003870						
2.0														
3.0														
3.8														
Carton coil length (m)	450	500	500	500	500	500	500	500	500	500	500	500	500	500

Missing catalog numbers available upon request.

DRIPPERLINES TECHNICAL DATA

MODEL	INSIDE DIAMETER (MM)	WALL THICKNESS (MM)	OUTSIDE DIAMETER (MM)	MAX. WORKING PRESSURE (BAR)	MAXIMUM FLUSHING PRESSURE (BAR)	KD
25250	25.00	0.63	26.26	2.0	2.3	0.04

DRIPPERLINES PACKAGE DATA (ON CARTON COILS)

MODEL	WALL THICKNESS (MM)	DISTANCE BETWEEN DRIPPERS (M)	COIL LENGTH (M)	AVERAGE* COIL WEIGHT (KG)	COILS PER PALLET (UNITS)	COILS IN A 40 FEET CONTAINER (UNITS)	TOTAL IN A 40 FEET CONTAINER (M)
25250	0.63	0.15 to 0.19	450	20.9	12	480	216000
		0.20 to 0.35	500	25.0			240000
		0.40 to 1.00	500	24.7			240000

*According to drippers spacing



DRIPNET PC™ HWD

COMPACT INTEGRAL PRESSURE-COMPENSATING,
CONTINUOUSLY SELF-CLEANING DRIPPER



12009 - 12010 - 16009 - 16010 - 16012 - 20010 - 20012 - 23009

APPLICATIONS

On-surface multi seasonal row crops.

FEATURES AND BENEFITS

- Pressure compensated: Precise and equal amounts of water are delivered over a broad pressure range. 100% uniformity of water and nutrient distribution along the laterals.
- Continuously self flushing: Continuously flushing debris, throughout operation, not just at the beginning or end of a cycle, ensuring uninterrupted dripper operation.
- Self-flushing system with wide filtration area improves resistance to clogging Which allows reduction in the filtration requirements and increasing the filtration efficiency.
- TurboNet™ labyrinth assures wide water passages, large deep and wide cross section improves clogging resistance.
- The water is drawn in to the dripper from the stream center, preventing the entrance of sediments in to the drippers.

SPECIFICATIONS

- Pressure-compensating range: 0.25/ 0.40/ 0.60-2.5/ 3.0/ 3.5 bar (according to flow rate model).
- Recommended filtration: according to drippers flow rate.
Filtration method is to be selected based on the kind and concentration of the dirt particles existing in the water. Wherever sand exceeding 2 ppm exists in the water, a Hydrocyclone is to be installed before the main filter. When sand/ silt/ clay solids exceed 100 ppm, pre treatment will be applied according to Netafim™ expert team's instructions.
- TurboNet™ labyrinth with large water passage.
- To be "welded" into thick-walled dripperlines (0.90, 1.00, 1.20 mm).
- Injected dripper, very low CV.
- Injected silicon diaphragm.
- High UV resistant. Resistant to standard nutrients used in agricultural.
- DripNet PC™ dripperlines meet ISO 9261 Standards with production certified by the Israel Standards Institute (SII).

DRIPPERS TECHNICAL DATA

FLOW RATE* (L/H)	WORKING PRESSURE RANGE (BAR)	WATER PASSAGES DIMENSIONS WIDTH-DEPTH-LENGTH (MM)	FILTRATION AREA (MM²)	CONSTANT K	EXPONENT* X	RECOMMENDED FILTRATION (MICRON)/(MESH)
0.4	0.25 - 2.5	0.46 x 0.52 x 26	29	0.4	0	130/120
0.6	0.25 - 2.5	0.52 x 0.60 x 22	39	0.6	0	130/120
1.0	0.40 - 3.0	0.61 x 0.60 x 8	39	1.0	0	130/120
1.6	0.40 - 3.0	0.76 x 0.73 x 8	39	1.6	0	200/80
2.0	0.40 - 3.5	0.84 x 0.80 x 8	39	2.0	0	200/80
3.0	0.40 - 3.5	1.02 x 0.88 x 8	39	3.0	0	200/80
3.8	0.60 - 3.5	1.02 x 0.88 x 8	39	3.8	0	200/80

* Within working pressure range

DRIPNET PC™ 12009

Catalog number **17171** - (any of below 6 digits)

FLOW RATE (L/H)	DISTANCE BETWEEN DRIPPERS (M)													
	0.15	0.20	0.25	0.30	0.33	0.40	0.50	0.60	0.65	0.70	0.75	0.80	0.90	1.00
0.4														
0.6														
1.0		000100												
1.6				000200										
2.0														
3.0														
3.8														
Bundled coil length (m)	500	500	500	500	500	500	500	500	500	500	500	500	500	500

Missing catalog numbers available upon request.

DRIPPERLINES TECHNICAL DATA

MODEL	INSIDE DIAMETER (MM)	WALL THICKNESS (MM)	OUTSIDE DIAMETER (MM)	MAX. WORKING PRESSURE (BAR)	MAXIMUM FLUSHING PRESSURE (BAR)	KD
12009	10.60	0.90	12.40	2.5/3.0/3.5*	3.9	2.85

*The maximum working pressure is defined by the dripper or by the dripperline wall thickness

DRIPPERLINES PACKAGE DATA (ON BUNDLED COILS)

MODEL	WALL THICKNESS (MM)	DISTANCE BETWEEN DRIPPERS (M)	COIL LENGTH (M)	AVERAGE* COIL WEIGHT (KG)	COILS IN A 40 FEET CONTAINER (UNITS)	TOTAL IN A 40 FEET CONTAINER (M)
12009	0.90	0.15 to 1.00	500	168.5	384	192000

*According to drippers spacing

DRIPNET PC™ 12010

Catalog number **17173** - (any of below 6 digits)

FLOW RATE (L/H)	DISTANCE BETWEEN DRIPPERS (M)													
	0.15	0.20	0.25	0.30	0.33	0.40	0.50	0.60	0.65	0.70	0.75	0.80	0.90	1.00
0.4														
0.6														
1.0		000100												
1.6				000200										
2.0														
3.0														
3.8														
Bundled coil length (m)	500	500	500	500	500	500	500	500	500	500	500	500	500	500

Missing catalog numbers available upon request.

DRIPPERLINES TECHNICAL DATA

MODEL	INSIDE DIAMETER (MM)	WALL THICKNESS (MM)	OUTSIDE DIAMETER (MM)	MAX. WORKING PRESSURE (BAR)	MAXIMUM FLUSHING PRESSURE (BAR)	KD
12010	10.60	1.00	12.60	2.5/3.0/3.5*	4.6	2.85

*The maximum working pressure is defined by the dripper or by the dripperline wall thickness

DRIPPERLINES PACKAGE DATA (ON BUNDLED COILS)

MODEL	WALL THICKNESS (MM)	DISTANCE BETWEEN DRIPPERS (M)	COIL LENGTH (M)	AVERAGE* COIL WEIGHT (KG)	COILS IN A 40 FEET CONTAINER (UNITS)	TOTAL IN A 40 FEET CONTAINER (M)
12010	1.00	0.15 to 1.00	500	18.3	384	192000

*According to drippers spacing

DRIPNET PCT™ 16009

Catalog number **17650** - (any of below 6 digits)

FLOW RATE (L/H)	DISTANCE BETWEEN DRIPPERS (M)													
	0.15	0.20	0.25	0.30	0.33	0.40	0.50	0.60	0.65	0.70	0.75	0.80	0.90	1.00
0.4		000100												
0.6		002325	002335	002340		002890	003210	003300			003400	003500		
1.0		004160	004250	004560	004580	004760	004920	005155		005350	005450	005650	005800	006010
1.6		006250	006470	006660		006860	007060	007230	007239	007250	007550	007760	007950	008130
2.0		008350	008360	008400	008405	008470	008510	008610	008650	008700	008800	008910		009100
3.0				010050		010260	010460	010650	010750	011050	011400	011550	011750	012000
3.8				013100		013300	013500	013600	013650	013700	013800	013900	013970	014100
Bundled coil length (m)	500	500	500	500	500	500	500	500	500	500	500	500	500	500

Missing catalog numbers available upon request.

DRIPPERLINES TECHNICAL DATA

MODEL	INSIDE DIAMETER (MM)	WALL THICKNESS (MM)	OUTSIDE DIAMETER (MM)	MAX. WORKING PRESSURE (BAR)	MAXIMUM FLUSHING PRESSURE (BAR)	KD
16009	14.20	0.90	16.00	2.5/3.0/3.5*	3.9	0.72

*The maximum working pressure is defined by the dripper or by the dripperline wall thickness

DRIPPERLINES PACKAGE DATA (ON BUNDLED COILS)

MODEL	WALL THICKNESS (MM)	DISTANCE BETWEEN DRIPPERS (M)	COIL LENGTH (M)	AVERAGE* COIL WEIGHT (KG)	COILS IN A 40 FEET CONTAINER (UNITS)	TOTAL IN A 40 FEET CONTAINER (M)
16009	0.90	0.15 to 1.00	500	18.5	330	165000

*According to drippers spacing

DRIPNET PCT™ 16010

Catalog number **17665** - (any of below 6 digits)

FLOW RATE (L/H)	DISTANCE BETWEEN DRIPPERS (M)													
	0.15	0.20	0.25	0.30	0.33	0.40	0.50	0.60	0.65	0.70	0.75	0.80	0.90	1.00
0.4							000100							
0.6	000250	000370	000390	000547	000600	000620	000700	000750	000780	000790	000800	000900	000925	000950
1.0	001060	001160	001450	001625		001820	001875	002060	002125	002160	002200	002600	002800	003050
1.6	005820	006025	006075	006270	006280	006470	006620	006860	006890	007000	007210	007460	007550	007830
2.0		008430	008460	008530	005833	008550	008600	009592	009587	008570	009594	009595	009596	009597
3.0		009620	009635	009685	009690	009790	009940	010120	010160	010250	010530	010720	010800	011120
3.8		012300	012350	012400		012560	012600	012700	012735	012750	012800	012830	012860	013000
Bundled coil length (m)	500	500	500	500	500	500	500	500		500	500	500	500	500

Missing catalog numbers available upon request.

DRIPPERLINES TECHNICAL DATA

MODEL	INSIDE DIAMETER (MM)	WALL THICKNESS (MM)	OUTSIDE DIAMETER (MM)	MAX. WORKING PRESSURE (BAR)	MAXIMUM FLUSHING PRESSURE (BAR)	KD
16010	14.20	1.00	16.20	2.5/3.0/3.5*	4.6	0.72

*The maximum working pressure is defined by the dripper or by the dripperline wall thickness

DRIPPERLINES PACKAGE DATA (ON BUNDLED COILS)

MODEL	WALL THICKNESS (MM)	DISTANCE BETWEEN DRIPPERS (M)	COIL LENGTH (M)	AVERAGE* COIL WEIGHT (KG)	COILS IN A 40 FEET CONTAINER (UNITS)	TOTAL IN A 40 FEET CONTAINER (M)
16010	1.00	0.15 to 1.00	500	20.4	330	165000

*According to drippers spacing

DRIPNET PC™ 16012

Catalog number **17668** - (any of below 6 digits)

FLOW RATE (L/H)	DISTANCE BETWEEN DRIPPERS (M)													
	0.15	0.20	0.25	0.30	0.33	0.40	0.50	0.60	0.65	0.70	0.75	0.80	0.90	1.00
0.4														
0.6						001400								
1.0		002400	002500	002600			002630							
1.6		003720			003755	003760	004000	004100						
2.0		005700		005710		005900	006000	006100			006300			006600
3.0								008100						008500
3.8		000001		008900		000002	009000	009100			009300		009590	009600
Bundled coil length (m)	400	400	400	400	400	400	400	400	400	400	400	400	400	400

Missing catalog numbers available upon request.

DRIPPERLINES TECHNICAL DATA

MODEL	INSIDE DIAMETER (MM)	WALL THICKNESS (MM)	OUTSIDE DIAMETER (MM)	MAX. WORKING PRESSURE (BAR)	MAXIMUM FLUSHING PRESSURE (BAR)	KD
16012	14.20	1.20	16.60	2.5/3.0/3.5*	5.2	0.72

* The maximum working pressure is defined by the dripper not by the dripperline wall thickness

DRIPPERLINES PACKAGE DATA (ON BUNDLED COILS)

MODEL	WALL THICKNESS (MM)	DISTANCE BETWEEN DRIPPERS (M)	COIL LENGTH (M)	AVERAGE* COIL WEIGHT (KG)	COILS IN A 40 FEET CONTAINER (UNITS)	TOTAL IN A 40 FEET CONTAINER (M)
16012	1.20	0.15 to 1.00	400	22.4	352	140800

*According to drippers spacing

DRIPNET PC™ 20010

Catalog number **17690** - (any of below 6 digits)

FLOW RATE (L/H)	DISTANCE BETWEEN DRIPPERS (M)													
	0.15	0.20	0.25	0.30	0.33	0.40	0.50	0.60	0.65	0.70	0.75	0.80	0.90	1.00
0.4				000100										
0.6		001000		001100	001150		001380							001800
1.0		001930	001950	002120	002210	002320	002500	002650			002830	002900	003030	003130
1.6		003650		003920	003925	004050	004320	004520	004580		004700	004920	004950	005000
2.0		005200	005220	005230	005280	005330	005400	005490	005494	005495	005497	005620	005650	005700
3.0		005780	005800	005900	005950	006100	006250	006620	006680		006800	007050	008050	009050
3.8		011850	011900	011970	012100	012200	012300	012400	012410	012760	012850	012970	013100	013450
Bundled coil length (m)	300	300	300	300	300	300	300	300	300	300	300	300	300	300

Missing catalog numbers available upon request.

DRIPPERLINES TECHNICAL DATA

MODEL	INSIDE DIAMETER (MM)	WALL THICKNESS (MM)	OUTSIDE DIAMETER (MM)	MAX. WORKING PRESSURE (BAR)	MAXIMUM FLUSHING PRESSURE (BAR)	KD
20010	17.50	1.00	19.50	2.5/3.0/3.5*	4.6	0.25

*The maximum working pressure is defined by the dripper or by the dripperline wall thickness

DRIPPERLINES PACKAGE DATA (ON BUNDLED COILS)

MODEL	WALL THICKNESS (MM)	DISTANCE BETWEEN DRIPPERS (M)	COIL LENGTH (M)	AVERAGE* COIL WEIGHT (KG)	COILS IN A 40 FEET CONTAINER (UNITS)	TOTAL IN A 40 FEET CONTAINER (M)
20010	1.00	0.15 to 1.00	300	16.8	330	99000

*According to drippers spacing

DRIPNET PCT™ 20012

Catalog number **17725** - (any of below 6 digits)

FLOW RATE (L/H)	DISTANCE BETWEEN DRIPPERS (M)													
	0.15	0.20	0.25	0.30	0.33	0.40	0.50	0.60	0.65	0.70	0.75	0.80	0.90	1.00
0.4														
0.6		001000	001120	001250										
1.0		001990	002050	002150		002220	002240	002260						
1.6		003690		003700		003900	004000	004060						000001
2.0				005300		005400	005500	005550				005570		005600
3.0							007490	007500			007600	007650		007900
3.8						000003	009000	009100			009300	009400		009600
Bundled coil length (m)	300	300	300	300	300	300	300	300	300	300	300	300	300	300

Missing catalog numbers available upon request.

DRIPPERLINES TECHNICAL DATA

MODEL	INSIDE DIAMETER (MM)	WALL THICKNESS (MM)	OUTSIDE DIAMETER (MM)	MAX. WORKING PRESSURE (BAR)	MAXIMUM FLUSHING PRESSURE (BAR)	KD
20012	17.50	1.20	19.90	2.5/3.0/3.5*	5.2	0.25

* The maximum working pressure is defined by the dripper not by the dripperline wall thickness

DRIPPERLINES PACKAGE DATA (ON BUNDLED COILS)

MODEL	WALL THICKNESS (MM)	DISTANCE BETWEEN DRIPPERS (M)	COIL LENGTH (M)	AVERAGE* COIL WEIGHT (KG)	COILS IN A 40 FEET CONTAINER (UNITS)	TOTAL IN A 40 FEET CONTAINER (M)
20012	1.20	0.15 to 1.00	300	20.3	330	99000

*According to drippers spacing

DRIPNET PCT™ 23009

Catalog number **17700** - (any of below 6 digits)

FLOW RATE (L/H)	DISTANCE BETWEEN DRIPPERS (M)													
	0.15	0.20	0.25	0.30	0.33	0.40	0.50	0.60	0.65	0.70	0.75	0.80	0.90	1.00
0.4														
0.6				001150		001250	001450	001550			001750			001950
1.0		002210		002900		003250	003450	003650			003850			004450
1.6				004950				005750		005795	006000			006600
2.0						007010	007030	007080						
3.0				007400		007500	007580	007700			007900			008500
3.8														
Carton coil length (m)	350	350	350	400	400	400	400	400	400	400	400	400	400	400

Missing catalog numbers available upon request.

DRIPPERLINES TECHNICAL DATA

MODEL	INSIDE DIAMETER (MM)	WALL THICKNESS (MM)	OUTSIDE DIAMETER (MM)	MAX. WORKING PRESSURE (BAR)	MAXIMUM FLUSHING PRESSURE (BAR)	KD
23009	20.80	0.90	22.60	2.5/3.0/3.5*	3.5	0.20

*The maximum working pressure is defined by the dripper or by the dripperline wall thickness

DRIPPERLINES PACKAGE DATA (ON CARTON COILS)

MODEL	WALL THICKNESS (MM)	DISTANCE BETWEEN DRIPPERS (M)	COIL LENGTH (M)	AVERAGE* COIL WEIGHT (KG)	COILS IN A 40 FEET CONTAINER (UNITS)	TOTAL IN A 40 FEET CONTAINER (M)
23009	0.90	0.15 to 0.25	350	22.5	480	168000
		0.30 to 1.00	400	25.0		192000

*According to drippers spacing





DRIPNET PC™ AS HWD

COMPACT INTEGRAL PRESSURE-COMPENSATING,
CONTINUOUSLY SELF-CLEANING, ANTI-SIPHON
MECHANISM DRIPPER



12009 - 12010 - 16009 - 16010 - 16012 - 20010 - 20012 - 23009

APPLICATIONS

Sub-surface multi seasonal row crops.

FEATURES AND BENEFITS

- Pressure compensated: Precise and equal amounts of water are delivered over a broad pressure range. 100% uniformity of water and nutrient distribution along the laterals.
- Anti-Siphon mechanism: Prevents contaminants from being drawn into the dripper, which is needed in sub surface applications.
- Continuously self flushing: Continuously flushing debris, throughout operation, not just at the beginning or end of a cycle, ensuring uninterrupted dripper operation. This allows reduction in the filtration requirements, and increases filtration efficiency.
- Self-flushing system with wide filtration area improves resistance to clogging.
- TurboNet™ labyrinth assures wide water passages, large deep and wide cross section improves clogging resistance.

SPECIFICATIONS

- Pressure-compensating range: 0.25/ 0.40/ 0.60-2.5/ 3.0/ 3.5 bar (according to flow rate mode).
- Anti-Siphon mechanism.
- Recommended filtration: according to drippers flow rate.
Filtration method is to be selected based on the kind and concentration of the dirt particles existing in the water. Wherever sand exceeding 2 ppm exists in the water, a Hydrocyclone is to be installed before the main filter. When sand/ silt/ clay solids exceed 100 ppm, pre treatment will be applied according to Netafim™ expert team's instructions.
- TurboNet™ labyrinth with large water passage.
- To be "welded" into thick-walled dripperlines (0.90, 1.00, 1.20 mm).
- Injected dripper, very low CV.
- Injected silicon diaphragm.
- High UV resistant. Resistant to standard nutrients used in agricultural.
- DripNet PC™ dripperlines meet ISO 9261 Standards with production certified by the Israel Standards Institute (SII).

DRIPPERS TECHNICAL DATA

FLOW RATE* (L/H)	WORKING PRESSURE RANGE (BAR)	WATER PASSAGES DIMENSIONS WIDTH-DEPTH-LENGTH (MM)	FILTRATION AREA (MM²)	CONSTANT K	EXPONENT* X	RECOMMENDED FILTRATION (MICRON)/(MESH)
0.6	0.25 - 2.5	0.52 x 0.60 x 22	42	0.6	0	130/120
1.0	0.40 - 3.0	0.61 x 0.60 x 8	42	1.0	0	130/120
1.6	0.40 - 3.0	0.76 x 0.73 x 8	42	1.6	0	200/80
2.0	0.40 - 3.5	0.84 x 0.80 x 8	42	2.0	0	200/80
3.0	0.40 - 3.5	1.02 x 0.88 x 8	42	3.0	0	200/80
3.8	0.60 - 3.5	1.02 x 0.88 x 8	42	3.8	0	200/80

* Within working pressure range

DRIPNET PC™ AS 12009

Catalog number **17172** - (any of below 6 digits)

FLOW RATE (L/H)	DISTANCE BETWEEN DRIPPERS (M)													
	0.15	0.20	0.25	0.30	0.33	0.40	0.50	0.60	0.65	0.70	0.75	0.80	0.90	1.00
0.6														
1.0		000100												
1.6				000200										
2.0														
3.0														
3.8														
Bundled coil length (m)	500	500	500	500	500	500	500	500	500	500	500	500	500	500

Missing catalog numbers available upon request.

DRIPPERLINES TECHNICAL DATA

MODEL	INSIDE DIAMETER (MM)	WALL THICKNESS (MM)	OUTSIDE DIAMETER (MM)	MAX. WORKING PRESSURE (BAR)	MAXIMUM FLUSHING PRESSURE (BAR)	KD
12009	10.60	0.90	12.40	2.5/3.0/3.5*	3.9	2.85

*The maximum working pressure is defined by the dripper or by the dripperline wall thickness

DRIPPERLINES PACKAGE DATA (ON BUNDLED COILS)

MODEL	WALL THICKNESS (MM)	DISTANCE BETWEEN DRIPPERS (M)	COIL LENGTH (M)	AVERAGE* COIL WEIGHT (KG)	COILS IN A 40 FEET CONTAINER (UNITS)	TOTAL IN A 40 FEET CONTAINER (M)
12009	0.90	0.15 to 1.00	500	16.5	384	192000

*According to drippers spacing

DRIPNET PC™ AS 12010

Catalog number **17174** - (any of below 6 digits)

FLOW RATE (L/H)	DISTANCE BETWEEN DRIPPERS (M)													
	0.15	0.20	0.25	0.30	0.33	0.40	0.50	0.60	0.65	0.70	0.75	0.80	0.90	1.00
0.6														
1.0		000100												
1.6				000200										
2.0														
3.0														
3.8														
Bundled coil length (m)	500	500	500	500	500	500	500	500	500	500	500	500	500	500

Missing catalog numbers available upon request.

DRIPPERLINES TECHNICAL DATA

MODEL	INSIDE DIAMETER (MM)	WALL THICKNESS (MM)	OUTSIDE DIAMETER (MM)	MAX. WORKING PRESSURE (BAR)	MAXIMUM FLUSHING PRESSURE (BAR)	KD
12010	10.60	1.00	12.60	2.5/3.0/3.5*	4.6	2.85

*The maximum working pressure is defined by the dripper or by the dripperline wall thickness

DRIPPERLINES PACKAGE DATA (ON BUNDLED COILS)

MODEL	WALL THICKNESS (MM)	DISTANCE BETWEEN DRIPPERS (M)	COIL LENGTH (M)	AVERAGE* COIL WEIGHT (KG)	COILS IN A 40 FEET CONTAINER (UNITS)	TOTAL IN A 40 FEET CONTAINER (M)
12010	1.00	0.15 to 1.00	500	18.3	384	192000

*According to drippers spacing

DRIPNET PC™ AS 16009

Catalog number **17655** - (any of below 6 digits)

FLOW RATE (L/H)	DISTANCE BETWEEN DRIPPERS (M)													
	0.15	0.20	0.25	0.30	0.33	0.40	0.50	0.60	0.65	0.70	0.75	0.80	0.90	1.00
0.6	000890	000900	001100	001200		001300	002000	002100	002130	002200	002300			
1.0	002750	002850		002950		003100	003400	003610	003650		003730			
1.6	002951	004250		004300		004400	004610	004750	004760	004800	004860	004900	002960	004920
2.0		005050	005065	005100	005110	005150	005200	005250		005400	005550	005553	005551	005595
3.0		005640		005700		005750	005800	005850	005860	006000	006070	006100	000001	006150
3.8						006700		006720			007100	007200		007250
Bundled coil length (m)	500	500	500	500	500	500	500	500	500	500	500	500	500	500

Missing catalog numbers available upon request.

DRIPPERLINES TECHNICAL DATA

MODEL	INSIDE DIAMETER (MM)	WALL THICKNESS (MM)	OUTSIDE DIAMETER (MM)	MAX. WORKING PRESSURE (BAR)	MAXIMUM FLUSHING PRESSURE (BAR)	KD
16009	14.20	0.90	16.00	2.5/3.0/3.5*	3.9	0.72

*The maximum working pressure is defined by the dripper or by the dripperline wall thickness

DRIPPERLINES PACKAGE DATA (ON BUNDLED COILS)

MODEL	WALL THICKNESS (MM)	DISTANCE BETWEEN DRIPPERS (M)	COIL LENGTH (M)	AVERAGE* COIL WEIGHT (KG)	COILS IN A 40 FEET CONTAINER (UNITS)	TOTAL IN A 40 FEET CONTAINER (M)
16009	0.90	0.15 to 1.00	500	18.5	330	165000

*According to drippers spacing

DRIPNET PC™ AS 16010

Catalog number **17705** - (any of below 6 digits)

FLOW RATE (L/H)	DISTANCE BETWEEN DRIPPERS (M)													
	0.15	0.20	0.25	0.30	0.33	0.40	0.50	0.60	0.65	0.70	0.75	0.80	0.90	1.00
0.6		001400	001500	001410		001700	001800				001850			
1.0	002600	002710	002730	002800		002910	003000	003100			003300	003330	003340	003500
1.6	004100	004210		004300	004330	004400	004500	004600			004700	004800	004850	005000
2.0		000002	005690	005700		005820	005900	006000			006200	006250	006390	006400
3.0		000004		006790		006800	006900	007000		007100	007120	007300		007500
3.8				008950	009000	009145	009150	009160	009170		009200	009300		009500
Bundled coil length (m)	500	500	500	500	500	500	500	500	500	500	500	500	500	500

Missing catalog numbers available upon request.

DRIPPERLINES TECHNICAL DATA

MODEL	INSIDE DIAMETER (MM)	WALL THICKNESS (MM)	OUTSIDE DIAMETER (MM)	MAX. WORKING PRESSURE (BAR)	MAXIMUM FLUSHING PRESSURE (BAR)	KD
16010	14.20	1.00	16.20	2.5/3.0/3.5*	4.6	0.72

*The maximum working pressure is defined by the dripper or by the dripperline wall thickness

DRIPPERLINES PACKAGE DATA (ON BUNDLED COILS)

MODEL	WALL THICKNESS (MM)	DISTANCE BETWEEN DRIPPERS (M)	COIL LENGTH (M)	AVERAGE* COIL WEIGHT (KG)	COILS IN A 40 FEET CONTAINER (UNITS)	TOTAL IN A 40 FEET CONTAINER (M)
16010	1.00	0.15 to 1.00	500	20.4	330	165000

*According to drippers spacing

DRIPNET PC™ AS 16012

Catalog number **17669** - (any of below 6 digits)

FLOW RATE (L/H)	DISTANCE BETWEEN DRIPPERS (M)													
	0.15	0.20	0.25	0.30	0.33	0.40	0.50	0.60	0.65	0.70	0.75	0.80	0.90	1.00
0.6	001000			001030		001040								
1.0		002570		002590		002690	002710							
1.6		004480		004500		004510	004520							
2.0							005400			005520				006000
3.0														
3.8								009100			009300			
Bundled coil length (m)	400	400	400	400	400	400	400	400	400	400	400	400	400	400

Missing catalog numbers available upon request.

DRIPPERLINES TECHNICAL DATA

MODEL	INSIDE DIAMETER (MM)	WALL THICKNESS (MM)	OUTSIDE DIAMETER (MM)	MAX. WORKING PRESSURE (BAR)	MAXIMUM FLUSHING PRESSURE (BAR)	KD
16012	14.20	1.20	16.60	2.5/3.0/3.5*	5.2	0.72

* The maximum working pressure is defined by the dripper not by the dripperline wall thickness

DRIPPERLINES PACKAGE DATA (ON BUNDLED COILS)

MODEL	WALL THICKNESS (MM)	DISTANCE BETWEEN DRIPPERS (M)	COIL LENGTH (M)	AVERAGE* COIL WEIGHT (KG)	COILS IN A 40 FEET CONTAINER (UNITS)	TOTAL IN A 40 FEET CONTAINER (M)
16012	1.20	0.15 to 1.00	400	21.0	352	140800

*According to drippers spacing

DRIPNET PC™ AS 20010

Catalog number **17750** - (any of below 6 digits)

FLOW RATE (L/H)	DISTANCE BETWEEN DRIPPERS (M)													
	0.15	0.20	0.25	0.30	0.33	0.40	0.50	0.60	0.65	0.70	0.75	0.80	0.90	1.00
0.6		000300		000340	000350	000490	000500	000530						
1.0		001060		001170		001200	001300	001400			001500			001700
1.6		002270		002290		002650	002900	002990			003100	003200		003400
2.0				003800		003900	004000	004010			004040	004050		004070
3.0				005150		005300	005400	005500				005550	000003	006000
3.8		007090	007100	007200	007230	007300	007500	007550				007600		
Bundled coil length (m)	300	300	300	300	300	300	300	300	300	300	300	300	300	300

Missing catalog numbers available upon request.

DRIPPERLINES TECHNICAL DATA

MODEL	INSIDE DIAMETER (MM)	WALL THICKNESS (MM)	OUTSIDE DIAMETER (MM)	MAX. WORKING PRESSURE (BAR)	MAXIMUM FLUSHING PRESSURE (BAR)	KD
20010	17.50	1.00	19.50	2.5/3.0/3.5*	4.6	0.25

*The maximum working pressure is defined by the dripper or by the dripperline wall thickness

DRIPPERLINES PACKAGE DATA (ON BUNDLED COILS)

MODEL	WALL THICKNESS (MM)	DISTANCE BETWEEN DRIPPERS (M)	COIL LENGTH (M)	AVERAGE* COIL WEIGHT (KG)	COILS IN A 40 FEET CONTAINER (UNITS)	TOTAL IN A 40 FEET CONTAINER (M)
20010	1.00	0.15 to 1.00	300	16.3	330	99000

*According to drippers spacing

DRIPNET PC™ AS 20012

Catalog number **17728** - (any of below 6 digits)

FLOW RATE (L/H)	DISTANCE BETWEEN DRIPPERS (M)													
	0.15	0.20	0.25	0.30	0.33	0.40	0.50	0.60	0.65	0.70	0.75	0.80	0.90	1.00
0.6				001900		002000	002100							
1.0		003130		003200		003350	003420							
1.6		004880		004900		005000	005100							000001
2.0			005600	005670		005680	005900	006000						
3.0												006980		007000
3.8							009000	009100			009300			009600
Bundled coil length (m)	300	300	300	300	300	300	300	300	300	300	300	300	300	300

Missing catalog numbers available upon request.

DRIPPERLINES TECHNICAL DATA

MODEL	INSIDE DIAMETER (MM)	WALL THICKNESS (MM)	OUTSIDE DIAMETER (MM)	MAX. WORKING PRESSURE (BAR)	MAXIMUM FLUSHING PRESSURE (BAR)	KD
20012	17.50	1.20	19.90	2.5/3.0/3.5*	5.2	0.25

* The maximum working pressure is defined by the dripper not by the dripperline wall thickness

DRIPPERLINES PACKAGE DATA (ON BUNDLED COILS)

MODEL	WALL THICKNESS (MM)	DISTANCE BETWEEN DRIPPERS (M)	COIL LENGTH (M)	AVERAGE* COIL WEIGHT (KG)	COILS IN A 40 FEET CONTAINER (UNITS)	TOTAL IN A 40 FEET CONTAINER (M)
20012	1.20	0.15 to 1.00	300	20.0	330	99000

*According to drippers spacing

DRIPNET PC™ AS 23009

Catalog number **17800** - (any of below 6 digits)

FLOW RATE (L/H)	DISTANCE BETWEEN DRIPPERS (M)													
	0.15	0.20	0.25	0.30	0.33	0.40	0.50	0.60	0.65	0.70	0.75	0.80	0.90	1.00
0.6				001200		001300	001400	001500			001700			001900
1.0		002250		002300		002400	002500	002565	002650		002700			003000
1.6	003020			003200		003250	003400	003700	003800	003880	003900			004300
2.0				004400		004500	004600	004650			004680			004686
3.0	004700			005000		005200	005400	005600			006000			
3.8														
Carton coil length (m)	350	350	350	400	400	400	400	400	400	400	400	400	400	400

Missing catalog numbers available upon request.

DRIPPERLINES TECHNICAL DATA

MODEL	INSIDE DIAMETER (MM)	WALL THICKNESS (MM)	OUTSIDE DIAMETER (MM)	MAX. WORKING PRESSURE (BAR)	MAXIMUM FLUSHING PRESSURE (BAR)	KD
23009	20.80	0.90	22.60	2.5/3.0/3.5*	3.5	0.20

*The maximum working pressure is defined by the dripper or by the dripperline wall thickness

DRIPPERLINES PACKAGE DATA (ON CARTON COILS)

MODEL	WALL THICKNESS (MM)	DISTANCE BETWEEN DRIPPERS (M)	COIL LENGTH (M)	AVERAGE* COIL WEIGHT (KG)	COILS IN A 40 FEET CONTAINER (UNITS)	TOTAL IN A 40 FEET CONTAINER (M)
23009	0.90	0.15 to 0.25	350	22.5	480	168000
		0.30 to 1.00	400	25.0		192000

*According to drippers spacing





ARIES™ HWD

INTEGRAL DRIPPER



12010 - 16009 - 16010 - 16012 - 20010 - 20012 - 23009

APPLICATIONS

- Deciduous plantation, and tree irrigation.
- On-surface multi seasonal row crops.

FEATURES AND BENEFITS

- Largest filter in each dripper. Wide filtration area to ensure optimal performance even under harsh water conditions.
- TurbuNext™ labyrinth assures wide water passages, large deep and wide cross section improves clogging resistance.
- The water is drawn in to the dripper from the stream center, preventing the entrance of sediments in to the drippers.
- Injection molded dripper construction , ensuring uniform drippers and very low CV.

SPECIFICATIONS

- Maximum system pressure: according to dripperlines wall thickness.
- Recommended filtration: according to drippers flow rates.
Filtration method is to be selected based on the kind and concentration of the dirt particles existing in the water.
Wherever sand exceeding 2 ppm exists in the water, a Hydrocyclone is to be installed before the main filter.
When sand/ silt/ clay solids exceed 100 ppm, pre treatment will be applied according to Netafim™ expert team's instructions.
- TurbuNext™ labyrinth with superior performance.
- To be "welded" into thick-walled dripperlines (0.90, 1.00, 1.20 mm).
- Injected dripper, very low CV.
- High UV resistant.
- Resistant to standard nutrients used in agricultural.
- Aries™ dripperlines meet ISO 9261 Standards with production certified by the Israel Standards Institute (SII).

DRIPPERS TECHNICAL DATA

12010, 16009, 16010, 20010, 23009 - 0.9 and 1.0 mm wall thickness dripperlines

FLOW RATE* (L/H)	MAXIMUM WORKING PRESSURE (BAR)**	WATER PASSAGES DIMENSIONS WIDTH-DEPTH-LENGTH (MM)			FILTRATION AREA (MM ²)	CONSTANT K	EXPONENT X	RECOMMENDED FILTRATION (MICRON)/(MESH)
		Width	Depth	Length				
0.55	3.0 up to 3.5	0.47	0.53	65	36	0.191	0.46	130/120
0.80		0.54	0.69	65	43	0.277	0.46	130/120
1.00		0.60	0.74	65	49	0.347	0.46	200/80
1.50		0.71	0.85	65	53	0.520	0.46	200/80
2.00		0.76	1.03	65	54	0.693	0.46	200/80
3.00		0.90	1.20	65	54	1.040	0.46	200/80
4.00		0.94	1.28	33	54	1.387	0.46	200/80
8.00		1.52	1.28	28	50	2.773	0.46	200/80

*Flow rate at 1.0 bar pressure **According to dripperlines wall thickness

16012, 20012 - 1.2 mm wall thickness dripperlines

FLOW RATE* (L/H)	MAXIMUM WORKING PRESSURE (BAR)**	WATER PASSAGES DIMENSIONS WIDTH-DEPTH-LENGTH (MM)			FILTRATION AREA (MM ²)	CONSTANT K	EXPONENT X	RECOMMENDED FILTRATION (MICRON)/(MESH)
		Width	Depth	Length				
0.55	4.00	0.47	0.53	65	36	0.191	0.46	130/120
0.85		0.54	0.69	65	43	0.295	0.46	130/120
1.05		0.60	0.74	65	49	0.364	0.46	200/80
1.60		0.71	0.85	65	53	0.554	0.46	200/80
2.10		0.76	1.03	65	54	0.728	0.46	200/80
3.15		0.90	1.20	65	54	1.092	0.46	200/80
4.20		0.94	1.28	33	54	1.455	0.46	200/80
8.40		1.52	1.28	28	50	2.912	0.46	200/80

*Flow rate at 1.0 bar pressure *Flow rate at 1.0 bar pressure

ARIES™ HWD 12010

Catalog number **12730** - (any of below 6 digits)

FLOW RATE (L/H)	DISTANCE BETWEEN DRIPPERS (M)													
	0.15	0.20	0.25	0.30	0.33	0.40	0.50	0.60	0.65	0.70	0.75	0.80	0.90	1.00
0.55				000900										
0.80														
1.00		001900		002000		002100	002200	002300			002320			
1.50		002950		002955		002960		000001						
2.00				003000		003350	003300	003400			003600			003800
3.00														
4.00				005900		005950	006000	006100			006200			006800
8.00														
Bundled coil length (m)	500	500	500	500	500	500	500	500	500	500	500	500	500	500

Missing catalog numbers available upon request.

DRIPPERLINES TECHNICAL DATA

MODEL	INSIDE DIAMETER (MM)	WALL THICKNESS (MM)	OUTSIDE DIAMETER (MM)	MAX. WORKING PRESSURE (BAR)	MAXIMUM FLUSHING PRESSURE (BAR)	KD
12010	10.30	1.00	12.30	4.0	5.2	0.70

DRIPPERLINES PACKAGE DATA (ON BUNDLED COILS)

MODEL	WALL THICKNESS (MM)	COIL LENGTH (M)	DISTANCE BETWEEN DRIPPERS (M)	AVERAGE* COIL WEIGHT (KG)	COILS IN A 40 FEET CONTAINER (UNITS)	TOTAL IN A 40 FEET CONTAINER (M)
12010	1.00	500	0.15 to 1.00	20.6	370	185000

*According to drippers spacing

ARIES™ HWD 16009

Catalog number **12800** - (any of below 6 digits)

FLOW RATE (L/H)	DISTANCE BETWEEN DRIPPERS (M)													
	0.15	0.20	0.25	0.30	0.33	0.40	0.50	0.60	0.65	0.70	0.75	0.80	0.90	1.00
0.55				000700										
0.80														
1.00		001020	001040	001050		001100	001150	001200		001220	001250	001260		
1.50		001480	001490	001500		001550	001600	001650			001700		001800	001850
2.00		002550	002600	002650	002660	002700	002750	002800			002850	002860	002870	002900
3.00		003050	003100	003150		003200	003250	003300			003350	003360	003385	003390
4.00			029930	030000	030020	030100	030200	030300	030350	030400	030500	030550	030570	030700
8.00						032060	032070							
Bundled coil length (m)	500	500	500	500	500	500	500	500	500	500	500	500	500	500

Missing catalog numbers available upon request.

DRIPPERLINES TECHNICAL DATA

MODEL	INSIDE DIAMETER (MM)	WALL THICKNESS (MM)	OUTSIDE DIAMETER (MM)	MAX. WORKING PRESSURE (BAR)	MAXIMUM FLUSHING PRESSURE (BAR)	KD
16009	14.20	0.90	16.00	3.0	3.9	0.40

DRIPPERLINES PACKAGE DATA (ON BUNDLED COILS)

MODEL	WALL THICKNESS (MM)	COIL LENGTH (M)	DISTANCE BETWEEN DRIPPERS (M)	AVERAGE* COIL WEIGHT (KG)	COILS IN A 40 FEET CONTAINER (UNITS)	TOTAL IN A 40 FEET CONTAINER (M)
16009	0.90	500	0.15 to 1.00	20.7	330	165000

*According to drippers spacing

ARIES™ HWD 16010

Catalog number **12820** - (any of below 6 digits)

FLOW RATE (L/H)	DISTANCE BETWEEN DRIPPERS (M)													
	0.15	0.20	0.25	0.30	0.33	0.40	0.50	0.60	0.65	0.70	0.75	0.80	0.90	1.00
0.55				000600										
0.80														
1.00		000800	000950	001000		001100	001150	001200			001250	001300	000002	001400
1.50		006990	006996	007000		007100	007200	007220			007240			007500
2.00	002290	002400	002430	002600	002658	002700	002730	002750		002756	002770	002800	002850	002900
3.00		000006	003980	004000		004100	004200	004300			004350	004400		004500
4.00		005500		005600	005610	005700	005800	005900		005960	006000	006100	006150	006200
8.00			000007	008000		000001		008050						
Bundled coil length (m)	500	500	500	500	500	500	500	500	500	500	500	500	500	500

Missing catalog numbers available upon request.

DRIPPERLINES TECHNICAL DATA

MODEL	INSIDE DIAMETER (MM)	WALL THICKNESS (MM)	OUTSIDE DIAMETER (MM)	MAX. WORKING PRESSURE (BAR)	MAXIMUM FLUSHING PRESSURE (BAR)	KD
16010	14.20	1.00	16.20	3.5	4.6	0.40

DRIPPERLINES PACKAGE DATA (ON BUNDLED COILS)

MODEL	WALL THICKNESS (MM)	COIL LENGTH (M)	DISTANCE BETWEEN DRIPPERS (M)	AVERAGE* COIL WEIGHT (KG)	COILS IN A 40 FEET CONTAINER (UNITS)	TOTAL IN A 40 FEET CONTAINER (M)
16010	1.00	500	0.15 to 1.00	23.0	330	165000

*According to drippers spacing

ARIES™ HWD 16012

Catalog number **12840** - (any of below 6 digits)

FLOW RATE (L/H)	DISTANCE BETWEEN DRIPPERS (M)													
	0.15	0.20	0.25	0.30	0.33	0.40	0.50	0.60	0.65	0.70	0.75	0.80	0.90	1.00
0.55				009000										
0.85														
1.05		000110		000120		000130								
1.60				001500		001530	001560							
2.10				002500		002600	002700				002750			
3.15								004500						
4.20		006000		006210		006200	006250							006500
8.40														
Bundled coil length (m)	400	400	400	400	400	400	400	400	400	400	400	400	400	400

Missing catalog numbers available upon request.

DRIPPERLINES TECHNICAL DATA

MODEL	INSIDE DIAMETER (MM)	WALL THICKNESS (MM)	OUTSIDE DIAMETER (MM)	MAX. WORKING PRESSURE (BAR)	MAXIMUM FLUSHING PRESSURE (BAR)	KD
16012	14.20	1.20	16.60	4.0	5.2	0.40

DRIPPERLINES PACKAGE DATA (ON BUNDLED COILS)

MODEL	WALL THICKNESS (MM)	DISTANCE BETWEEN DRIPPERS (M)	COIL LENGTH (M)	AVERAGE* COIL WEIGHT (KG)	COILS IN A 40 FEET CONTAINER (UNITS)	TOTAL IN A 40 FEET CONTAINER (M)
16012	1.20	0.20 to 1.00	400	22.3	352	140800

*According to drippers spacing

ARIES™ HWD 20010

Catalog number **12880** - (any of below 6 digits)

FLOW RATE (L/H)	DISTANCE BETWEEN DRIPPERS (M)													
	0.15	0.20	0.25	0.30	0.33	0.40	0.50	0.60	0.65	0.70	0.75	0.80	0.90	1.00
0.55				000600										
0.80	001000													
1.00		002000	002050	002100		002150	002200	002250			002300	002350		
1.50		002450		007430		007460	007480	007500						
2.00		003500	003550	003600	003590	003650	003700	003750		003770	003800	003900	004000	004050
3.00		004500	004550	004600		004650	004700	004750			004800	004850		004880
4.00		004900	004950	005000	005020	005050	005100	005150		005200	005250	005710	005750	005950
8.00			008900	008910			008960	008970			008980		009000	009020
Bundled coil length (m)	300	300	300	300	300	300	300	300	300	300	300	300	300	300

Missing catalog numbers available upon request.

DRIPPERLINES TECHNICAL DATA

MODEL	INSIDE DIAMETER (MM)	WALL THICKNESS (MM)	OUTSIDE DIAMETER (MM)	MAX. WORKING PRESSURE (BAR)	MAXIMUM FLUSHING PRESSURE (BAR)	KD
20010	17.50	1.00	19.50	3.5	4.6	0.10

DRIPPERLINES PACKAGE DATA (ON BUNDLED COILS)

MODEL	WALL THICKNESS (MM)	COIL LENGTH (M)	DISTANCE BETWEEN DRIPPERS (M)	AVERAGE* COIL WEIGHT (KG)	COILS IN A 40 FEET CONTAINER (UNITS)	TOTAL IN A 40 FEET CONTAINER (M)
20010	1.00	300	0.15 to 1.00	16.7	330	99000

*According to drippers spacing

ARIES™ HWD 20012

Catalog number **12890** - (any of below 6 digits)

FLOW RATE (L/H)	DISTANCE BETWEEN DRIPPERS (M)													
	0.15	0.20	0.25	0.30	0.33	0.40	0.50	0.60	0.65	0.70	0.75	0.80	0.90	1.00
0.55				000900										
0.85														
1.05		001400		001500		001600	001650							
1.60				002630		002640								002680
2.10		003550		003600		003700	003800	003900			004050	004070		004200
3.15						004500	004520	004550				004800		004900
4.20						005000	005100	006000		006020	006200	006220		006250
8.40														
Bundled coil length (m)	300	300	300	300	300	300	300	300	300	300	300	300	300	300

Missing catalog numbers available upon request.

DRIPPERLINES TECHNICAL DATA

MODEL	INSIDE DIAMETER (MM)	WALL THICKNESS (MM)	OUTSIDE DIAMETER (MM)	MAX. WORKING PRESSURE (BAR)	MAXIMUM FLUSHING PRESSURE (BAR)	KD
20012	1750	1.20	19.90	4.0	5.2	0.10

DRIPPERLINES PACKAGE DATA (ON BUNDLED COILS)

MODEL	WALL THICKNESS (MM)	COIL LENGTH (M)	DISTANCE BETWEEN DRIPPERS (M)	AVERAGE* COIL WEIGHT (KG)	COILS IN A 40 FEET CONTAINER (UNITS)	TOTAL IN A 40 FEET CONTAINER (M)
20012	1.20	300	0.15 to 1.00	20.2	330	99000

*According to drippers spacing





12200 - 12250 - 16200 - 16250 - 16007
16008 - 22200 - 22250 - 25200

ARIES™ MWD

INTEGRAL DRIPPER

APPLICATIONS

- On-surface multi seasonal row crops.
- Permanent sub-surface multi seasonal row crops.

FEATURES AND BENEFITS

- Large filter in each dripper. Wide filtration area to ensure optimal performance even under harsh water conditions.
- TurbuNext™ labyrinth assures wide water passages, large deep and wide cross section improves clogging resistance.
- The water is drawn in to the dripper from the stream center, preventing the entrance of sediments in to the drippers.
- Injection molded dripper construction , ensuring uniform drippers and very low CV.

SPECIFICATIONS

- Maximum system pressure: according to dripperlines wall thickness.
- Recommended filtration: according to drippers flow rates.
Filtration method is to be selected based on the kind and concentration of the dirt particles existing in the water. Wherever sand exceeding 2 ppm exists in the water, a Hydrocyclone is to be installed before the main filter. When sand/silt/clay solids exceed 100 ppm, pre treatment will be applied according to Netafim™ expert team's instructions.
- TurbuNext™ labyrinth with superior clogging resistance..
- To be "welded" into medium-walled dripperlines (0.50, 0.63, 0.70, 0.80 mm).
- Injected dripper, very low CV.
- High UV resistance.
- Resistant to standard nutrients used in agricultural.
- Aries™ dripperlines meet ISO 9261 Standards with production certified by the Israel Standards Institute (SII).

DRIPPERS TECHNICAL DATA

12200, 16200, 22200, 25200, 12250, 16250, 22250 - 0.50 and 0.63 mm wall thickness dripperlines

FLOW RATE* (L/H)	MAXIMUM WORKING PRESSURE (BAR)**	WATER PASSAGES DIMENSIONS WIDTH-DEPTH-LENGTH (MM)			FILTRATION AREA (MM²)	CONSTANT K	EXPONENT X	RECOMMENDED FILTRATION (MICRON)/(MESH)
		Width	Depth	Length				
0.50	1.6 up to 3.5	0.47	0.53	65	36	0.173	0.46	130/120
0.80		0.54	0.69	65	43	0.277	0.46	130/120
1.00		0.60	0.74	65	49	0.347	0.46	200/80
1.40		0.71	0.85	65	53	0.485	0.46	200/80
1.90		0.76	1.03	65	54	0.659	0.46	200/80
2.85		0.90	1.20	65	54	0.988	0.46	200/80
3.80		0.94	1.28	33	54	1.316	0.46	200/80
8.00		1.52	1.28	28	50	2.773	0.46	200/80

*Flow rate at 1.0 bar pressure **According to dripperlines diameter and wall thicknesses

DRIPPERS TECHNICAL DATA

16007 - 0.70 mm wall thickness dripperlines

FLOW RATE* (L/H)	MAXIMUM WORKING PRESSURE (BAR)**	WATER PASSAGES DIMENSIONS WIDTH-DEPTH-LENGTH (MM)			FILTRATION AREA (MM ²)	CONSTANT K	EXPONENT X	RECOMMENDED FILTRATION (MICRON)/(MESH)
0.55	2.9	0.47	0.53	65	36	0.191	0.46	130/120
0.80		0.54	0.69	65	43	0.277	0.46	130/120
1.00		0.60	0.74	65	49	0.347	0.46	200/80
1.40		0.71	0.85	65	53	0.485	0.46	200/80
1.90		0.76	1.03	65	54	0.659	0.46	200/80
2.85		0.90	1.20	65	54	0.988	0.46	200/80
3.80		0.94	1.28	33	54	1.316	0.46	200/80
8.00		1.52	1.28	28	50	2.773	0.46	200/80

*Flow rate at 1.0 bar pressure

DRIPPERS TECHNICAL DATA

16008 - 0.8 mm wall thickness dripperlines

FLOW RATE* (L/H)	MAXIMUM WORKING PRESSURE (BAR)**	WATER PASSAGES DIMENSIONS WIDTH-DEPTH-LENGTH (MM)			FILTRATION AREA (MM ²)	CONSTANT K	EXPONENT X	RECOMMENDED FILTRATION (MICRON)/(MESH)
0.55	3.0	0.47	0.53	65	36	0.191	0.46	130/120
0.80		0.54	0.69	65	43	0.277	0.46	130/120
1.00		0.60	0.74	65	49	0.347	0.46	200/80
1.50		0.71	0.85	65	53	0.520	0.46	200/80
2.00		0.76	1.03	65	54	0.693	0.46	200/80
3.00		0.90	1.20	65	54	1.040	0.46	200/80
4.00		0.94	1.28	33	54	1.387	0.46	200/80
8.00		1.52	1.28	28	50	2.773	0.46	200/80

*Flow rate at 1.0 bar pressure

ARIES™ MWD 12200

Catalog number 12750 - (any of below 6 digits)

FLOW RATE (L/H)	DISTANCE BETWEEN DRIPPERS (M)													
	0.15	0.20	0.25	0.30	0.35	0.40	0.50	0.60	0.65	0.70	0.75	0.80	0.90	1.00
0.50				000100										
0.80														
1.00				001000		001010								
1.40				002040		002045								
1.90						003000	003300							
2.85						004100	004300							
3.80														
8.00				007000										
Carton coil length (m)	800	800	800	900	900	900	900	900	900	900	900	900	900	900

Missing catalog numbers available upon request.

DRIPPERLINES TECHNICAL DATA

MODEL	INSIDE DIAMETER (MM)	WALL THICKNESS (MM)	OUTSIDE DIAMETER (MM)	MAX. WORKING PRESSURE (BAR)	MAXIMUM FLUSHING PRESSURE (BAR)	KD
12200	11.80	0.50	12.80	3.0	3.9	0.40

DRIPPERLINES PACKAGE DATA (ON CARTON COILS)

MODEL	WALL THICKNESS (MM)	DISTANCE BETWEEN DRIPPERS (M)	COIL LENGTH (M)	AVERAGE* COIL WEIGHT (KG)	COILS IN A 40 FEET CONTAINER (UNITS)	TOTAL IN A 40 FEET CONTAINER (M)
12200	0.50	0.15 to 0.25	800	176	480	384000
		0.30 to 1.00	900	18.8	480	432000

*According to drippers spacing

ARIES™ MWD 12250

Catalog number **12760** - (any of below 6 digits)

FLOW RATE (L/H)	DISTANCE BETWEEN DRIPPERS (M)													
	0.15	0.20	0.25	0.30	0.35	0.40	0.50	0.60	0.65	0.70	0.75	0.80	0.90	1.00
0.50				000100										
0.80														
1.00		001000	001005	001020		001040								
1.40														
1.90														
2.85														
3.80														
8.00				007000										
Carton coil length (m)	700	700	700	750	750	750	750	750	750	750	750	750	750	750

Missing catalog numbers available upon request.

DRIPPERLINES TECHNICAL DATA

MODEL	INSIDE DIAMETER (MM)	WALL THICKNESS (MM)	OUTSIDE DIAMETER (MM)	MAX. WORKING PRESSURE (BAR)	MAXIMUM FLUSHING PRESSURE (BAR)	KD
12250	11.80	0.63	13.06	3.5	4.6	0.40

DRIPPERLINES PACKAGE DATA (ON CARTON COILS)

MODEL	WALL THICKNESS (MM)	DISTANCE BETWEEN DRIPPERS (M)	COIL LENGTH (M)	AVERAGE* COIL WEIGHT (KG)	COILS IN A 40 FEET CONTAINER (UNITS)	TOTAL IN A 40 FEET CONTAINER (M)
12250	0.63	0.15 to 0.25	700	19.0	480	336000
		0.30 to 1.00	750	19.6	480	360000

*According to drippers spacing

ARIES™ MWD 16200

Catalog number **12930** - (any of below 6 digits)

FLOW RATE (L/H)	DISTANCE BETWEEN DRIPPERS (M)													
	0.15	0.20	0.25	0.30	0.35	0.40	0.50	0.60	0.65	0.70	0.75	0.80	0.90	1.00
0.50				009000										
0.80	008000													
1.00		000020		000050		000070								000140
1.40		000180		000200		000210	000220	000230		000240				
1.90		000710		000870		004550	002700	002720						
2.85		004110		004150		004250	004600							
3.80		006110		006150		006200	006260	006310						
8.00				010000										
Carton coil length (m)	850	850	850	900	900	900	900	900	900	900	900	900	900	900

Missing catalog numbers available upon request.

DRIPPERLINES TECHNICAL DATA

MODEL	INSIDE DIAMETER (MM)	WALL THICKNESS (MM)	OUTSIDE DIAMETER (MM)	MAX. WORKING PRESSURE (BAR)	MAXIMUM FLUSHING PRESSURE (BAR)	KD
16200	15.50	0.50	16.50	2.5	3.3	0.35

DRIPPERLINES PACKAGE DATA (ON CARTON COILS)

MODEL	WALL THICKNESS (MM)	DISTANCE BETWEEN DRIPPERS (M)	COIL LENGTH (M)	AVERAGE* COIL WEIGHT (KG)	COILS IN A 40 FEET CONTAINER (UNITS)	TOTAL IN A 40 FEET CONTAINER (M)
16200	0.50	0.15 to 0.25	850	23.1	480	408000
		0.30 to 1.00	900	23.7	480	432000

*According to drippers spacing

ARIES™ MWD 16250

Catalog number **12940** - (any of below 6 digits)

FLOW RATE (L/H)	DISTANCE BETWEEN DRIPPERS (M)													
	0.15	0.20	0.25	0.30	0.35	0.40	0.50	0.60	0.65	0.70	0.75	0.80	0.90	1.00
0.50				007000										
0.80	000100													
1.00	000900	001020		001052	001057	001080	001090							
1.40				001500		001510	001520	001530						
1.90		002420		002460	002480	002605	002630	002730						
2.85						005570	005590		005610		005630			
3.80														
8.00				009000										
Carton coil length (m)	750	750	750	800	800	800	800	800	800	800	800	800	800	800

Missing catalog numbers available upon request.

DRIPPERLINES TECHNICAL DATA

MODEL	INSIDE DIAMETER (MM)	WALL THICKNESS (MM)	OUTSIDE DIAMETER (MM)	MAX. WORKING PRESSURE (BAR)	MAXIMUM FLUSHING PRESSURE (BAR)	KD
16250	15.50	0.63	16.76	2.8	3.6	0.35

DRIPPERLINES PACKAGE DATA (ON CARTON COILS)

MODEL	WALL THICKNESS (MM)	DISTANCE BETWEEN DRIPPERS (M)	COIL LENGTH (M)	AVERAGE* COIL WEIGHT (KG)	COILS IN A 40 FEET CONTAINER (UNITS)	TOTAL IN A 40 FEET CONTAINER (M)
16250	0.63	0.15 to 0.25	750	25.4	480	360000
		0.30 to 1.00	800	26.3	480	384000

*According to drippers spacing

ARIES™ MWD 16008

Catalog number **12960** - (any of below 6 digits)

FLOW RATE (L/H)	DISTANCE BETWEEN DRIPPERS (M)													
	0.15	0.20	0.25	0.30	0.35	0.40	0.50	0.60	0.65	0.70	0.75	0.80	0.90	1.00
0.55				000700										
0.80														
1.00		001010		001060		001066	001071	001076			001100	001120		
1.50		001470		001500		001511	001521	001531			001541			001571
2.00		002355		002450		002600	002800	002811			002831			002871
3.00				004300			004350							
4.00				006300		006311	006321	006331			006341			006371
8.00														
Carton coil length (m)	450	500	500	500	500	500	500	500	500	500	500	500	500	500

Missing catalog numbers available upon request.

DRIPPERLINES TECHNICAL DATA

MODEL	INSIDE DIAMETER (MM)	WALL THICKNESS (MM)	OUTSIDE DIAMETER (MM)	MAX. WORKING PRESSURE (BAR)	MAXIMUM FLUSHING PRESSURE (BAR)	KD
16008	15.50	0.80	17.10	3.0	3.9	0.35

DRIPPERLINES PACKAGE DATA (ON CARTON COILS)

MODEL	WALL THICKNESS (MM)	DISTANCE BETWEEN DRIPPERS (M)	COIL LENGTH (M)	AVERAGE* COIL WEIGHT (KG)	COILS IN A 40 FEET CONTAINER (UNITS)	TOTAL IN A 40 FEET CONTAINER (M)
16008	0.80	0.15	450	19.4	480	216000
		0.20 to 1.00	500	21.0	480	240000

*According to drippers spacing

ARIES™ MWD 22250

Catalog number **12970** - (any of below 6 digits)

FLOW RATE (L/H)	DISTANCE BETWEEN DRIPPERS (M)													
	0.15	0.20	0.25	0.30	0.35	0.40	0.50	0.60	0.65	0.70	0.75	0.80	0.90	1.00
0.50				000600										
0.80														
1.00				001900		002000	002100							
1.40				003100		003200	003250							
1.90														
2.85														
3.80														
8.00				009000										
Carton coil length (m)	550	550	550	600	600	600	600	600	600	600	600	600	600	600

Missing catalog numbers available upon request.

DRIPPERLINES TECHNICAL DATA

MODEL	INSIDE DIAMETER (MM)	WALL THICKNESS (MM)	OUTSIDE DIAMETER (MM)	MAX. WORKING PRESSURE (BAR)	MAXIMUM FLUSHING PRESSURE (BAR)	KD
22250	22.20	0.63	23.56	2.5	3.3	0.06

DRIPPERLINES PACKAGE DATA (ON CARTON COILS)

MODEL	WALL THICKNESS (MM)	DISTANCE BETWEEN DRIPPERS (M)	COIL LENGTH (M)	AVERAGE* COIL WEIGHT (KG)	COILS IN A 40 FEET CONTAINER (UNITS)	TOTAL IN A 40 FEET CONTAINER (M)
22250	0.63	0.15 to 0.25	550	25.7	480	264000
		0.30 to 1.00	600	27.4	480	288000

*According to drippers spacing





ARIES™ TWD

INTEGRAL DRIPPER



16125 - 16150 - 22125 – 22135 -22150

APPLICATIONS

- On-surface multi seasonal row crops.
- Permanent sub-surface multi seasonal row crops.

FEATURES AND BENEFITS

- Large filter in each dripper. Wide filtration area to ensure optimal performance even under harsh water conditions.
- TurbuNext™ labyrinth assures wide water passages, large deep and wide cross section improves clogging that allow reducing the filtration requirements, for drippers having 1.0l/h flowrate and above hence increasing the filtration efficiency.
- The water is drawn into the dripper from the stream center, preventing the entrance of sediments in to the drippers.
- Injection molded dripper construction, ensuring uniform dripper flow and very low CV.

SPECIFICATIONS

- Maximum system pressure: according to dripperlines wall thickness.
- Recommended filtration: according to drippers flow rates.
Filtration method is to be selected based on the kind and concentration of the dirt particles existing in the water. Wherever sand exceeding 2 ppm exists in the water, a Hydrocyclone is to be installed before the main filter. When sand/ silt/ clay solids exceed 100 ppm, pre treatment will be applied according to Netafim™ expert team's instructions.
- TurbuNext™ labyrinth with superior clogging resistance..
- To be "welded" into medium-walled dripperlines (0.31, 0.34, 0.38 mm).
- Injected dripper, very low CV.
- High UV resistant.
- Resistant to standard nutrients used in agricultural.
- Aries™ dripperlines meet ISO 9261 Standards with production certified by the Israel Standards Institute (SII).

DRIPPERS TECHNICAL DATA

12125, 12150, 16125, 16150, 22135, 22150 - 0.31, 0.34 and 0.38 mm wall thickness dripperlines

FLOW RATE* (L/H)	MAXIMUM WORKING PRESSURE (BAR)**	WATER PASSAGES DIMENSIONS WIDTH-DEPTH-LENGTH (MM)	FILTRATION AREA (MM²)	CONSTANT K	EXPONENT X	RECOMMENDED FILTRATION (MICRON)/(MESH)
0.50	1.5 up to 3.0	0.47 x 0.53 x 65	36	0.173	0.46	130/120
0.80		0.54 x 0.69 x 65	43	0.277	0.46	130/120
0.95		0.60 x 0.74 x 65	49	0.329	0.46	200/80
1.35		0.71 x 0.85 x 65	53	0.468	0.46	200/80
1.85		0.76 x 1.03 x 65	54	0.641	0.46	200/80
2.80		0.90 x 1.20 x 65	54	0.971	0.46	200/80
3.80		0.94 x 1.28 x 33	54	1.318	0.46	200/80
8.00		1.52 x 1.28 x 28	50	2.773	0.46	200/80

*Flow rate at 1.0 bar pressure **According to dripperlines wall thicknesses / inside diameter

ARIES™ TWD 12150

Catalog number **12740** - (any of below 6 digits)

FLOW RATE (L/H)	DISTANCE BETWEEN DRIPPERS (M)													
	0.15	0.20	0.25	0.30	0.33	0.40	0.50	0.60	0.65	0.70	0.75	0.80	0.90	1.00
0.50				000900										
0.80														
0.95		002010		002046										
1.35														
1.85														
2.80														
3.80														
8.00				007000										
Carton coil length (m)	1000	1100	1100	1200	1200	1200	1200	1200	1200	1200	1200	1200	1200	1200

Missing catalog numbers available upon request.

DRIPPERLINES TECHNICAL DATA

MODEL	INSIDE DIAMETER (MM)	WALL THICKNESS (MM)	OUTSIDE DIAMETER (MM)	MAX. WORKING PRESSURE (BAR)	MAXIMUM FLUSHING PRESSURE (BAR)	KD
12150	11.80	0.38	12.56	3.0	3.9	0.40

DRIPPERLINES PACKAGE DATA (ON CARTON COILS)

MODEL	WALL THICKNESS (MM)	DISTANCE BETWEEN DRIPPERS (M)	COIL LENGTH (M)	AVERAGE* COIL WEIGHT (KG)	COILS IN A 40 FEET CONTAINER (UNITS)	TOTAL IN A 40 FEET CONTAINER (M)
12150	0.38	0.15	1000	19.1	480	480000
		0.20 to 0.25	1100	19.3		528000
		0.30 to 1.00	1200	19.8		576000

*According to drippers spacing

ARIES™ TWD 16125

Catalog number **12935** - (any of below 6 digits)

FLOW RATE (L/H)	DISTANCE BETWEEN DRIPPERS (M)													
	0.15	0.20	0.25	0.30	0.33	0.40	0.50	0.60	0.65	0.70	0.75	0.80	0.90	1.00
0.50				001000										
0.80														
0.95	002210	002230		002300	002302	002310	003220							
1.35	006970	006990		007010		007030								
1.85		003245	003240	003300		003330	003360			003380				
2.80		004240		004300		004340	004400							
3.80		005220	005240	005300		005320	005340	005360						
8.00				009000										
Carton coil length (m)	1000	1000	1000	1100	1100	1100	1100	1100	1100	1100	1100	1100	1100	1100

Missing catalog numbers available upon request.

DRIPPERLINES TECHNICAL DATA

MODEL	INSIDE DIAMETER (MM)	WALL THICKNESS (MM)	OUTSIDE DIAMETER (MM)	MAX. WORKING PRESSURE (BAR)	MAXIMUM FLUSHING PRESSURE (BAR)	KD
16125	16.20	0.31	16.82	1.8	2.3	0.30

DRIPPERLINES PACKAGE DATA (ON CARTON COILS)

MODEL	WALL THICKNESS (MM)	DISTANCE BETWEEN DRIPPERS (M)	COIL LENGTH (M)	AVERAGE* COIL WEIGHT (KG)	COILS IN A 40 FEET CONTAINER (UNITS)	TOTAL IN A 40 FEET CONTAINER (M)
16125	0.31	0.15 to 0.25	1000	18.7	640	640000
		0.30 to 1.00	1100	19.5	640	704000

*According to drippers spacing

ARIES™ TWD 16150

Catalog number **12937** - (any of below 6 digits)

FLOW RATE (L/H)	DISTANCE BETWEEN DRIPPERS (M)													
	0.15	0.20	0.25	0.30	0.33	0.40	0.50	0.60	0.65	0.70	0.75	0.80	0.90	1.00
0.50				000900										
0.80				001100										
0.95		002020		002050	002056	002080	002090							
1.35		003030		003050		003070	003090							
1.85		003478		003500		003520	003540				003560			
2.80		004480		004500		004520		004600						
3.80				006000		006020	006040	006120						
8.00				009000										
Carton coil length (m)	900	900	900	1000	1000	1000	1000	1000	1000	1000	1000	1000	1000	1000

Missing catalog numbers available upon request.

DRIPPERLINES TECHNICAL DATA

MODEL	INSIDE DIAMETER (MM)	WALL THICKNESS (MM)	OUTSIDE DIAMETER (MM)	MAX. WORKING PRESSURE (BAR)	MAXIMUM FLUSHING PRESSURE (BAR)	KD
16150	16.20	0.38	16.96	2.2	2.9	0.30

DRIPPERLINES PACKAGE DATA (ON CARTON COILS)

MODEL	WALL THICKNESS (MM)	DISTANCE BETWEEN DRIPPERS (M)	COIL LENGTH (M)	AVERAGE* COIL WEIGHT (KG)	COILS IN A 40 FEET CONTAINER (UNITS)	TOTAL IN A 40 FEET CONTAINER (M)
16150	0.38	0.15 to 0.25	900	20.1	640	576000
		0.30 to 1.00	1000	21.4	640	640000

*According to drippers spacing

ARIES™ TWD 22125

Catalog number **12965** - (any of below 6 digits)

FLOW RATE (L/H)	DISTANCE BETWEEN DRIPPERS (M)													
	0.15	0.20	0.25	0.30	0.33	0.40	0.50	0.60	0.65	0.70	0.75	0.80	0.90	1.00
0.50				001000										
0.80														
0.95				002050		002100	002150							
1.35				002600		002640	002660							
1.85				003050		003100	003150							
2.80														
3.80										004000				
8.00														
Carton coil length (m)	900	900	900	1000	1000	1000	1000	1000	1000	1000	1000	1000	1000	1000

Missing catalog numbers available upon request.

DRIPPERLINES TECHNICAL DATA

MODEL	INSIDE DIAMETER (MM)	WALL THICKNESS (MM)	OUTSIDE DIAMETER (MM)	MAX. WORKING PRESSURE (BAR)	MAXIMUM FLUSHING PRESSURE (BAR)	KD
22125	22.20	0.31	22.82	1.5	2.0	0.06

DRIPPERLINES PACKAGE DATA (ON CARTON COILS)

MODEL	WALL THICKNESS (MM)	DISTANCE BETWEEN DRIPPERS (M)	COIL LENGTH (M)	AVERAGE* COIL WEIGHT (KG)	COILS IN A 40 FEET CONTAINER (UNITS)	TOTAL IN A 40 FEET CONTAINER (M)
22125	0.31	0.15 to 0.25	900	21.9	640	576000
		0.30 to 1.00	1000	23.4	640	640000

*According to drippers spacing





TYPHOON PLUS™

INTEGRAL DRIPPER

12080 - 12100 - 12125 - 12150 - 16080 - 16100 - 16125 - 16150
 16180 - 22080 - 22100 - 22125 - 22135 - 22150 - 22180 - 25080
 25100 - 25125 - 25135 - 25150

APPLICATIONS

- Row crops and vegetables, multi seasonal irrigation.
- On or Semi permanent sub surface installations.

BENEFITS AND FEATURES

High & uniform yield year after year

- Innovative labyrinth - TurbuNext™ - with wide water passages, large deep and wide cross section, allows usage of harsh water while using regular filtration technologies.
- Wide filtration area that ensures optimal performance even under harsh water conditions.
 The unique innovative labyrinth - TurbuNext™, with the wide filtration area allows reducing filtration requirements resulting in higher flushing efficiency, and waste of water and energy.
- Unique filter design, the water is drawn in to the dripper near the stream center, that prevents the entrance of sediments into the drippers.
- Typhoon Plus's exponent X is 0.45 meaning low variation between drippers along the lateral resulting in more uniform yield

Reliability & confidence

- The Typhoon Plus™ is manufactured according to the highest levels of quality control and assurance.
 Complying with International Standard ISO 9261.
- Injection molded dripper construction, ensuring uniform drippers and very low CV.

SPECIFICATIONS

- 5 different flow rates.
- Maximum system pressure: according to dripperlines diameters and wall thickness.
- Recommended filtration: according to dripper flow rate.
 Filtration method to be selected based on the kind and concentration of the contaminants existing in the water.
 Wherever sand exceeding 2 ppm exists in the water, a Hydrocyclon should be installed before the main filter.
 When sand / silt / clay exceed 100 ppm, pre-treatment should be applied according to Netafim™ expert team's instructions.
- Wide range of diameters and wall thicknesses.
 Diameter: from 12.0 to 25.0 mm.
 Wall thickness: from 0.20 to 0.45 mm (8 to 18 mil).
- Injected dripper, very low CV.
- High UV resistant.
- Resistant to standard nutrients used in agricultural.

DRIPPERS TECHNICAL DATA

FLOW RATE* (L/H)	MAXIMUM WORKING PRESSURE** (BAR)	WATER PASSAGES DIMENSIONS WIDTH-DEPTH-LENGTH (MM)	FILTRATION AREA (MM²)	CONSTANT K	EXPONENT X	RECOMMENDED FILTRATION (MICRON)/(MESH)
0.50	0.6 up to 3.0	0.45 x 0.45 x 34	21	0.177	0.45	130/120
0.70		0.52 x 0.51 x 34	22	0.247	0.45	130/120
1.00		0.60 x 0.59 x 34	24	0.355	0.45	200/80
1.60		0.66 x 0.63 x 18	24	0.567	0.45	200/80
2.20		0.77 x 0.72 x 18	24	0.780	0.45	200/80

*Flow rate at 1.0 bar pressure ** According to dripperlines diameter and wall thickness

TYPHOON PLUS™ 12125 (WITH HOLE OUTLET)

Catalog number **15686** - (any of below 6 digits)

FLOW RATE (L/H)	DISTANCE BETWEEN DRIPPERS (M)													
	0.15	0.20	0.25	0.30	0.35	0.40	0.50	0.60	0.65	0.70	0.75	0.80	0.90	1.00
0.50				000002		000004	000001							
0.70		000090												
1.00				000101										
1.60				000130										
2.20														
Carton coils length (m)	1200	1200	1200	1300	1300	1300	1300	1300	1300	1300	1300	1300	1300	1300

Missing catalog numbers available upon request.

DRIPPERLINES TECHNICAL DATA

MODEL	INSIDE DIAMETER (MM)	WALL THICKNESS (MM)	OUTSIDE DIAMETER (MM)	MAX. WORKING PRESSURE (BAR)	MAXIMUM FLUSHING PRESSURE (BAR)	KD
12125	11.80	0.31	12.42	2.5	2.9	0.20

DRIPPERLINES PACKAGE DATA (ON CARTON COILS)

MODEL	WALL THICKNESS (MM)	DISTANCE BETWEEN DRIPPERS (M)	COIL LENGTH (M)	AVERAGE* COIL WEIGHT (KG)	COILS PER PALLET (UNITS)	COILS IN A 40 FEET CONTAINER (UNITS)	TOTAL IN A 40 FEET CONTAINER (M)
12125	0.31	0.15 to 0.25	1200	15.6	16	640	768000
		0.30 to 1.00	1300	16.3			832000

*According to drippers spacing

TYPHOON PLUS™ 12150 (WITH HOLE OUTLET)

Catalog number **15688** - (any of below 6 digits)

FLOW RATE (L/H)	DISTANCE BETWEEN DRIPPERS (M)													
	0.15	0.20	0.25	0.30	0.35	0.40	0.50	0.60	0.65	0.70	0.75	0.80	0.90	1.00
0.50														
0.70														
1.00		000100		000130										
1.60														
2.20														
Carton coils length (m)	1100	1100	1100	1100	1100	1100	1100	1100	1100	1100	1100	1100	1100	1100

Missing catalog numbers available upon request.

DRIPPERLINES TECHNICAL DATA

MODEL	INSIDE DIAMETER (MM)	WALL THICKNESS (MM)	OUTSIDE DIAMETER (MM)	MAX. WORKING PRESSURE (BAR)	MAXIMUM FLUSHING PRESSURE (BAR)	KD
12150	11.80	0.38	12.56	3.0	3.5	0.20

DRIPPERLINES PACKAGE DATA (ON CARTON COILS)

MODEL	WALL THICKNESS (MM)	DISTANCE BETWEEN DRIPPERS (M)	COIL LENGTH (M)	AVERAGE* COIL WEIGHT (KG)	COILS PER PALLET (UNITS)	COILS IN A 40 FEET CONTAINER (UNITS)	TOTAL IN A 40 FEET CONTAINER (M)
12150	0.38	0.15 to 0.25	1100	17.2	16	640	704000
		0.30 to 1.00	1100	16.8			704000

*According to drippers spacing

TYPHOON PLUS™ 16080 (WITH FLAP OUTLET)

Catalog number **15690** - (any of below 6 digits)

FLOW RATE (L/H)	DISTANCE BETWEEN DRIPPERS (M)													
	0.15	0.20	0.25	0.30	0.35	0.40	0.50	0.60	0.65	0.70	0.75	0.80	0.90	1.00
0.50														
0.70		000072												
1.00		000090		000160										
1.60		000490	000520			000560								
2.20														
Carton coils length (m)	2400	2400	2400	2500	2500	2500	2500	2500	2500	2500	2500	2500	2500	2500

Missing catalog numbers available upon request.

TYPHOON PLUS™ 16080 (WITH HOLE OUTLET)

Catalog number **15690** - (any of below 6 digits)

FLOW RATE (L/H)	DISTANCE BETWEEN DRIPPERS (M)													
	0.15	0.20	0.25	0.30	0.35	0.40	0.50	0.60	0.65	0.70	0.75	0.80	0.90	1.00
0.50														
0.70		000070		000001										
1.00		000091	000100	000130	000260	000140								
1.60		000460		000530		000550								
2.20														
Carton coils length (m)	2400	2400	2400	2500	2500	2500	2500	2500	2500	2500	2500	2500	2500	2500

Missing catalog numbers available upon request.

DRIPPERLINES TECHNICAL DATA

MODEL	INSIDE DIAMETER (MM)	WALL THICKNESS (MM)	OUTSIDE DIAMETER (MM)	MAX. WORKING PRESSURE (BAR)	MAXIMUM FLUSHING PRESSURE (BAR)	KD
16080	16.20	0.20	16.60	1.2	1.4	0.10

DRIPPERLINES PACKAGE DATA (ON CARTON COILS)

MODEL	WALL THICKNESS (MM)	DISTANCE BETWEEN DRIPPERS (M)	COIL LENGTH (M)	AVERAGE* COIL WEIGHT (KG)	COILS PER PALLET (UNITS)	COILS IN A 40 FEET CONTAINER (UNITS)	TOTAL IN A 40 FEET CONTAINER (M)
16080	0.20	0.15 to 0.25	2400	26.9	16	640	1536000
		0.30 to 1.00	2500	27.1			1600000

*According to drippers spacing

TYPHOON PLUS™ 16100 (WITH FLAP OUTLET)

Catalog number **15695** - (any of below 6 digits)

FLOW RATE (L/H)	DISTANCE BETWEEN DRIPPERS (M)													
	0.15	0.20	0.25	0.30	0.35	0.40	0.50	0.60	0.65	0.70	0.75	0.80	0.90	1.00
0.50														
0.70						000090								
1.00		000100	000130	000160	000220	000250								
1.60		000410		000470	000500	000560								
2.20														
Carton coils length (m)	1900	1900	1900	2000	2000	2000	2000	2000	2000	2000	2000	2000	2000	2000

Missing catalog numbers available upon request.

TYPHOON PLUS™ 16100 (WITH HOLE OUTLET)

Catalog number **15695** - (any of below 6 digits)

FLOW RATE (L/H)	DISTANCE BETWEEN DRIPPERS (M)													
	0.15	0.20	0.25	0.30	0.35	0.40	0.50	0.60	0.65	0.70	0.75	0.80	0.90	1.00
0.50														
0.70														
1.00		000102		000162	000190	000252	000280							
1.60				000440		000530	000620	000650						
2.20														
Carton coils length (m)	1900	1900	1900	2000	2000	2000	2000	2000	2000	2000	2000	2000	2000	2000

Missing catalog numbers available upon request.

DRIPPERLINES TECHNICAL DATA

MODEL	INSIDE DIAMETER (MM)	WALL THICKNESS (MM)	OUTSIDE DIAMETER (MM)	MAX. WORKING PRESSURE (BAR)	MAXIMUM FLUSHING PRESSURE (BAR)	KD
16100	16.20	0.25	16.70	1.4	1.6	0.10

DRIPPERLINES PACKAGE DATA (ON CARTON COILS)

MODEL	WALL THICKNESS (MM)	DISTANCE BETWEEN DRIPPERS (M)	COIL LENGTH (M)	AVERAGE* COIL WEIGHT (KG)	COILS PER PALLET (UNITS)	COILS IN A 40 FEET CONTAINER (UNITS)	TOTAL IN A 40 FEET CONTAINER (M)
16100	0.25	0.15 to 0.25	1900	26.2	16	640	1216000
		0.30 to 1.00	2000	26.9			1280000

*According to drippers spacing

TYPHOON PLUS™ 16125 (WITH FLAP OUTLET)

Catalog number **15700** - (any of below 6 digits)

FLOW RATE (L/H)	DISTANCE BETWEEN DRIPPERS (M)													
	0.15	0.20	0.25	0.30	0.35	0.40	0.50	0.60	0.65	0.70	0.75	0.80	0.90	1.00
0.50														
0.70		000001		000100										
1.00		000230		000290		000350	000440							
1.60	000540			000630		000720		000780						
2.20														
Carton coils length (m)	1350	1350	1350	1600	1600	1600	1600	1600	1600	1600	1600	1600	1600	1600

Missing catalog numbers available upon request.

TYPHOON PLUS™ 16125 (WITH HOLE OUTLET)

Catalog number **15700** - (any of below 6 digits)

FLOW RATE (L/H)	DISTANCE BETWEEN DRIPPERS (M)													
	0.15	0.20	0.25	0.30	0.35	0.40	0.50	0.60	0.65	0.70	0.75	0.80	0.90	1.00
0.50		000010												
0.70	000002			000003		000110								
1.00		000200		000260	000320	000380	000410							
1.60			000600	000660	000665	000690	000750	000782						
2.20														
Carton coils length (m)	1350	1350	1350	1600	1600	1600	1600	1600	1600	1600	1600	1600	1600	1600

Missing catalog numbers available upon request.

DRIPPERLINES TECHNICAL DATA

MODEL	INSIDE DIAMETER (MM)	WALL THICKNESS (MM)	OUTSIDE DIAMETER (MM)	MAX. WORKING PRESSURE (BAR)	MAXIMUM FLUSHING PRESSURE (BAR)	KD
16125	16.20	0.31	16.82	1.8	2.1	0.10

DRIPPERLINES PACKAGE DATA (ON CARTON COILS)

MODEL	WALL THICKNESS (MM)	DISTANCE BETWEEN DRIPPERS (M)	COIL LENGTH (M)	AVERAGE* COIL WEIGHT (KG)	COILS PER PALLET (UNITS)	COILS IN A 40 FEET CONTAINER (UNITS)	TOTAL IN A 40 FEET CONTAINER (M)
16125	0.31	0.15 to 0.25	1350	26.2	16	640	864000
		0.30 to 1.00	1600	26.5			1024000

*According to drippers spacing

TYPHOON PLUS™ 16150 (WITH FLAP OUTLET)

Catalog number **15705** - (any of below 6 digits)

FLOW RATE (L/H)	DISTANCE BETWEEN DRIPPERS (M)													
	0.15	0.20	0.25	0.30	0.35	0.40	0.50	0.60	0.65	0.70	0.75	0.80	0.90	1.00
0.50														
0.70		000100		000130										
1.00				000290			000410							
1.60		000510		000540			000840	000940						
2.20														
Carton coils length (m)	1200	1200	1200	1300	1300	1300	1300	1300	1300	1300	1300	1300	1300	1300

Missing catalog numbers available upon request.

TYPHOON PLUS™ 16150 (WITH HOLE OUTLET)

Catalog number **15705** - (any of below 6 digits)

FLOW RATE (L/H)	DISTANCE BETWEEN DRIPPERS (M)													
	0.15	0.20	0.25	0.30	0.35	0.40	0.50	0.60	0.65	0.70	0.75	0.80	0.90	1.00
0.50														
0.70														
1.00		000230		000260	000320	000350	000380							
1.60				000640		000740								
2.20		000001												
Carton coils length (m)	1200	1200	1200	1300	1300	1300	1300	1300	1300	1300	1300	1300	1300	1300

Missing catalog numbers available upon request.

DRIPPERLINES TECHNICAL DATA

MODEL	INSIDE DIAMETER (MM)	WALL THICKNESS (MM)	OUTSIDE DIAMETER (MM)	MAX. WORKING PRESSURE (BAR)	MAXIMUM FLUSHING PRESSURE (BAR)	KD
16150	16.20	0.38	16.96	2.2	2.5	0.10

DRIPPERLINES PACKAGE DATA (ON CARTON COILS)

MODEL	WALL THICKNESS (MM)	DISTANCE BETWEEN DRIPPERS (M)	COIL LENGTH (M)	AVERAGE* COIL WEIGHT (KG)	COILS PER PALLET (UNITS)	COILS IN A 40 FEET CONTAINER (UNITS)	TOTAL IN A 40 FEET CONTAINER (M)
16150	0.38	0.15 to 0.25	1200	26.5	16	640	768000
		0.30 to 1.00	1300	26.0			832000

*According to drippers spacing

TYPHOON PLUS™ 16180 (WITH FLAP OUTLET)

Catalog number **15581** - (any of below 6 digits)

FLOW RATE (L/H)	DISTANCE BETWEEN DRIPPERS (M)													
	0.15	0.20	0.25	0.30	0.35	0.40	0.50	0.60	0.65	0.70	0.75	0.80	0.90	1.00
0.50														
0.70														
1.00														
1.60														
2.20														
Carton coils length (m)	1100	1100	1100	1200	1200	1200	1200	1200	1200	1200	1200	1200	1200	1200

Missing catalog numbers available upon request.

TYPHOON PLUS™ 16180 (WITH HOLE OUTLET)

Catalog number **15581** - (any of below 6 digits)

FLOW RATE (L/H)	DISTANCE BETWEEN DRIPPERS (M)													
	0.15	0.20	0.25	0.30	0.35	0.40	0.50	0.60	0.65	0.70	0.75	0.80	0.90	1.00
0.50														
0.70														
1.00														
1.60				000001										
2.20														
Carton coils length (m)	1100	1100	1100	1200	1200	1200	1200	1200	1200	1200	1200	1200	1200	1200

Missing catalog numbers available upon request.

DRIPPERLINES TECHNICAL DATA

MODEL	INSIDE DIAMETER (MM)	WALL THICKNESS (MM)	OUTSIDE DIAMETER (MM)	MAX. WORKING PRESSURE (BAR)	MAXIMUM FLUSHING PRESSURE (BAR)	KD
16180	16.20	0.45	17.10	2.5	0.10	0.10

DRIPPERLINES PACKAGE DATA (ON CARTON COILS)

MODEL	WALL THICKNESS (MM)	DISTANCE BETWEEN DRIPPERS (M)	COIL LENGTH (M)	AVERAGE* COIL WEIGHT (KG)	COILS PER PALLET (UNITS)	COILS IN A 40 FEET CONTAINER (UNITS)	TOTAL IN A 40 FEET CONTAINER (M)
16180	0.45	0.15 to 0.25	1100	26.6	16	640	704000
		0.30 to 1.00	1200	28.6			768000

*According to drippers spacing

TYPHOON PLUS™ 22080 (WITH FLAP OUTLET)

Catalog number **15710** - (any of below 6 digits)

FLOW RATE (L/H)	DISTANCE BETWEEN DRIPPERS (M)													
	0.15	0.20	0.25	0.30	0.35	0.40	0.50	0.60	0.65	0.70	0.75	0.80	0.90	1.00
0.50		001100		001115										
0.70			001150	001250		001350	001450							
1.00		001600		001750		001850	001950							002100
1.60				002200		002300	002350							
2.20				002400										
Carton coils length (m)	1500	1500	1500	1700	1700	1700	1700	1700	1700	1700	1700	1700	1700	1700

Missing catalog numbers available upon request.

TYPHOON PLUS™ 22080 (WITH HOLE OUTLET)

Catalog number **15710** - (any of below 6 digits)

FLOW RATE (L/H)	DISTANCE BETWEEN DRIPPERS (M)													
	0.15	0.20	0.25	0.30	0.35	0.40	0.50	0.60	0.65	0.70	0.75	0.80	0.90	1.00
0.50				001110										
0.70				001200		001300	001400	001500						
1.00		001560	001650	001700		001800	001900	002000						002050
1.60				002150		002250								
2.20							002450							
Carton coils length (m)	1500	1500	1500	1700	1700	1700	1700	1700	1700	1700	1700	1700	1700	1700

Missing catalog numbers available upon request.

DRIPPERLINES TECHNICAL DATA

MODEL	INSIDE DIAMETER (MM)	WALL THICKNESS (MM)	OUTSIDE DIAMETER (MM)	MAX. WORKING PRESSURE (BAR)	MAXIMUM FLUSHING PRESSURE (BAR)	KD
22080	22.20	0.20	22.60	1.0	1.2	0.02

DRIPPERLINES PACKAGE DATA (ON CARTON COILS)

MODEL	WALL THICKNESS (MM)	DISTANCE BETWEEN DRIPPERS (M)	COIL LENGTH (M)	AVERAGE* COIL WEIGHT (KG)	COILS PER PALLET (UNITS)	COILS IN A 40 FEET CONTAINER (UNITS)	TOTAL IN A 40 FEET CONTAINER (M)
22080	0.20	0.15 to 0.25	1500	26.9	16	640	960000
		0.30 to 1.00	1700	27.6			1088000

*According to drippers spacing

TYPHOON PLUS™ 22100 (WITH FLAP OUTLET)

Catalog number **15715** - (any of below 6 digits)

FLOW RATE (L/H)	DISTANCE BETWEEN DRIPPERS (M)													
	0.15	0.20	0.25	0.30	0.35	0.40	0.50	0.60	0.65	0.70	0.75	0.80	0.90	1.00
0.50														
0.70				001250		001350	001450	001550						
1.00		001600	001650	001750		001900	002000							
1.60				002200		002350	002500	002550						
2.20														
Carton coils length (m)	1200	1200	1200	1500	1500	1500	1500	1500	1500	1500	1500	1500	1500	1500

Missing catalog numbers available upon request.

TYPHOON PLUS™ 22100 (WITH HOLE OUTLET)

Catalog number **15715** - (any of below 6 digits)

FLOW RATE (L/H)	DISTANCE BETWEEN DRIPPERS (M)													
	0.15	0.20	0.25	0.30	0.35	0.40	0.50	0.60	0.65	0.70	0.75	0.80	0.90	1.00
0.50														
0.70				001200		001300	001400	001500						
1.00		001610		001700	001800	001850	001950	002050						
1.60		002100		002150		002300	002450							
2.20				002650										
Carton coils length (m)	1200	1200	1200	1500	1500	1500	1500	1500	1500	1500	1500	1500	1500	1500

Missing catalog numbers available upon request.

DRIPPERLINES TECHNICAL DATA

MODEL	INSIDE DIAMETER (MM)	WALL THICKNESS (MM)	OUTSIDE DIAMETER (MM)	MAX. WORKING PRESSURE (BAR)	MAXIMUM FLUSHING PRESSURE (BAR)	KD
22100	22.20	0.25	22.70	1.1	1.3	0.02

DRIPPERLINES PACKAGE DATA (ON CARTON COILS)

MODEL	WALL THICKNESS (MM)	DISTANCE BETWEEN DRIPPERS (M)	COIL LENGTH (M)	AVERAGE* COIL WEIGHT (KG)	COILS PER PALLET (UNITS)	COILS IN A 40 FEET CONTAINER (UNITS)	TOTAL IN A 40 FEET CONTAINER (M)
22100	0.25	0.15 to 0.25	1200	25.8	16	640	768000
		0.30 to 1.00	1500	27.1			960000

*According to drippers spacing

TYPHOON PLUS™ 22135 (WITH FLAP OUTLET)

Catalog number **15725** - (any of below 6 digits)

FLOW RATE (L/H)	DISTANCE BETWEEN DRIPPERS (M)													
	0.15	0.20	0.25	0.30	0.35	0.40	0.50	0.60	0.65	0.70	0.75	0.80	0.90	1.00
0.50														
0.70				001250	001300	001400	001500	001550						
1.00		001650		001750	001800	001900	002050	002150	002200		002250			
1.60		002350	002450	002550		002650	002750	002850	002950	003000	003050			003200
2.20				003300		003400	003500	003600						
Carton coils length (m)	1100	1100	1100	1100	1100	1100	1100	1100	1100	1100	1100	1100	1100	1100

Missing catalog numbers available upon request.

TYPHOON PLUS™ 22135 (WITH HOLE OUTLET)

Catalog number **15725** - (any of below 6 digits)

FLOW RATE (L/H)	DISTANCE BETWEEN DRIPPERS (M)													
	0.15	0.20	0.25	0.30	0.35	0.40	0.50	0.60	0.65	0.70	0.75	0.80	0.90	1.00
0.50														
0.70			001150	001200		001350	001450							
1.00		001600		001700		001850	002000	002100						
1.60		002300	002400	002500		002600	002700	002800				003100		003150
2.20				003250		003350	003450	003550						
Carton coils length (m)	1100	1100	1100	1100	1100	1100	1100	1100	1100	1100	1100	1100	1100	1100

Missing catalog numbers available upon request.

DRIPPERLINES TECHNICAL DATA

MODEL	INSIDE DIAMETER (MM)	WALL THICKNESS (MM)	OUTSIDE DIAMETER (MM)	MAX. WORKING PRESSURE (BAR)	MAXIMUM FLUSHING PRESSURE (BAR)	KD
22135	22.20	0.34	22.88	1.5	1.7	0.02

DRIPPERLINES PACKAGE DATA (ON CARTON COILS)

MODEL	WALL THICKNESS (MM)	DISTANCE BETWEEN DRIPPERS (M)	COIL LENGTH (M)	AVERAGE* COIL WEIGHT (KG)	COILS PER PALLET (UNITS)	COILS IN A 40 FEET CONTAINER (UNITS)	TOTAL IN A 40 FEET CONTAINER (M)
22135	0.34	0.15 to 0.25	1100	27.2	16	640	704000
		0.30 to 1.00	1100	26.8			704000

*According to drippers spacing

TYPHOON PLUS™ 22150 (WITH FLAP OUTLET)

Catalog number **15730** - (any of below 6 digits)

FLOW RATE (L/H)	DISTANCE BETWEEN DRIPPERS (M)													
	0.15	0.20	0.25	0.30	0.35	0.40	0.50	0.60	0.65	0.70	0.75	0.80	0.90	1.00
0.50														
0.70				001250	001300	001400	001500	001550						
1.00		001600		001700	001800	001900	002000	002050	002100					
1.60	002150	002200	002250	002300	002350	002450	002500	002600	002650		002700			
2.20				002850		002900	002950	003000		003050				
Carton coils length (m)	1000	1000	1000	1000	1000	1000	1000	1000	1000	1000	1000	1000	1000	1000

Missing catalog numbers available upon request.

TYPHOON PLUS™ 22150 (WITH HOLE OUTLET)

Catalog number **15730** - (any of below 6 digits)

FLOW RATE (L/H)	DISTANCE BETWEEN DRIPPERS (M)													
	0.15	0.20	0.25	0.30	0.35	0.40	0.50	0.60	0.65	0.70	0.75	0.80	0.90	1.00
0.50														
0.70		001100		001200		001350	001450							
1.00				001650	001750	001850	001950							
1.60				002800		002400								
2.20														
Carton coils length (m)	1000	1000	1000	1000	1000	1000	1000	1000	1000	1000	1000	1000	1000	1000

Missing catalog numbers available upon request.

DRIPPERLINES TECHNICAL DATA

MODEL	INSIDE DIAMETER (MM)	WALL THICKNESS (MM)	OUTSIDE DIAMETER (MM)	MAX. WORKING PRESSURE (BAR)	MAXIMUM FLUSHING PRESSURE (BAR)	KD
22150	22.20	0.38	22.96	1.8	2.1	0.02

DRIPPERLINES PACKAGE DATA (ON CARTON COILS)

MODEL	WALL THICKNESS (MM)	DISTANCE BETWEEN DRIPPERS (M)	COIL LENGTH (M)	AVERAGE* COIL WEIGHT (KG)	COILS PER PALLET (UNITS)	COILS IN A 40 FEET CONTAINER (UNITS)	TOTAL IN A 40 FEET CONTAINER (M)
22150	0.38	0.15 to 0.25	1000	27.6	16	640	640000
		0.30 to 1.00	1000	27.2			640000

*According to drippers spacing

TYPHOON PLUS™ 22180 (WITH FLAP OUTLET)

Catalog number **15731** - (any of below 6 digits)

FLOW RATE (L/H)	DISTANCE BETWEEN DRIPPERS (M)													
	0.15	0.20	0.25	0.30	0.35	0.40	0.50	0.60	0.65	0.70	0.75	0.80	0.90	1.00
0.50														
0.70														
1.00														
1.60														
2.20														
Carton coils length (m)	800	800	800	900	900	900	900	900	900	900	900	900	900	900

Missing catalog numbers available upon request.

TYPHOON PLUS™ 22180 (WITH HOLE OUTLET)

Catalog number **15731** - (any of below 6 digits)

FLOW RATE (L/H)	DISTANCE BETWEEN DRIPPERS (M)													
	0.15	0.20	0.25	0.30	0.35	0.40	0.50	0.60	0.65	0.70	0.75	0.80	0.90	1.00
0.50														
0.70														
1.00														
1.60				000001										
2.20														
Carton coils length (m)	800	800	800	900	900	900	900	900	900	900	900	900	900	900

Missing catalog numbers available upon request.

DRIPPERLINES TECHNICAL DATA

MODEL	INSIDE DIAMETER (MM)	WALL THICKNESS (MM)	OUTSIDE DIAMETER (MM)	MAX. WORKING PRESSURE (BAR)	MAXIMUM FLUSHING PRESSURE (BAR)	KD
22180	22.20	0.45	23.10	2.1	2.4	0.02

DRIPPERLINES PACKAGE DATA (ON CARTON COILS)

MODEL	WALL THICKNESS (MM)	DISTANCE BETWEEN DRIPPERS (M)	COIL LENGTH (M)	AVERAGE* COIL WEIGHT (KG)	COILS PER PALLET (UNITS)	COILS IN A 40 FEET CONTAINER (UNITS)	TOTAL IN A 40 FEET CONTAINER (M)
22180	0.45	0.15 to 0.25	800	26.0	16	640	512000
		0.30 to 1.00	900	28.8			576000

*According to drippers spacing

TYPHOON PLUS™ 25135 (WITH FLAP OUTLET)

Catalog number **15740** - (any of below 6 digits)

FLOW RATE (L/H)	DISTANCE BETWEEN DRIPPERS (M)													
	0.15	0.20	0.25	0.30	0.35	0.40	0.50	0.60	0.65	0.70	0.75	0.80	0.90	1.00
0.50														
0.70				001200										
1.00						001250	001300							
1.60						001450	001500							
2.20														
Carton coils length (m)	900	900	900	1000	1000	1000	1000	1000	1000	1000	1000	1000	1000	1000

Missing catalog numbers available upon request.

TYPHOON PLUS™ 25135 (WITH HOLE OUTLET)

Catalog number **15740** - (any of below 6 digits)

FLOW RATE (L/H)	DISTANCE BETWEEN DRIPPERS (M)													
	0.15	0.20	0.25	0.30	0.35	0.40	0.50	0.60	0.65	0.70	0.75	0.80	0.90	1.00
0.50														
0.70														
1.00														
1.60				001350		001400								
2.20														
Carton coils length (m)	900	900	900	1000	1000	1000	1000	1000	1000	1000	1000	1000	1000	1000

Missing catalog numbers available upon request.

DRIPPERLINES TECHNICAL DATA

MODEL	INSIDE DIAMETER (MM)	WALL THICKNESS (MM)	OUTSIDE DIAMETER (MM)	MAX. WORKING PRESSURE (BAR)	MAXIMUM FLUSHING PRESSURE (BAR)	KD
25135	25.00	0.34	25.68	1.2	1.4	0.01

DRIPPERLINES PACKAGE DATA (ON CARTON COILS)

MODEL	WALL THICKNESS (MM)	DISTANCE BETWEEN DRIPPERS (M)	COIL LENGTH (M)	AVERAGE* COIL WEIGHT (KG)	COILS PER PALLET (UNITS)	COILS IN A 40 FEET CONTAINER (UNITS)	TOTAL IN A 40 FEET CONTAINER (M)
25135	0.34	0.15 to 0.25	900	25.0	16	640	576000
		0.30 to 1.00	1000	27.3			640000

*According to drippers spacing

TYPHOON PLUS™ 25150 (WITH FLAP OUTLET)

Catalog number **15745** - (any of below 6 digits)

FLOW RATE (L/H)	DISTANCE BETWEEN DRIPPERS (M)													
	0.15	0.20	0.25	0.30	0.35	0.40	0.50	0.60	0.65	0.70	0.75	0.80	0.90	1.00
0.50						000500								
0.70				001200										
1.00				001250		001300	001350	001400						
1.60							001450	001500						
2.20														
Carton coils length (m)	900	900	900	900	900	900	900	900	900	900	900	900	900	900

Missing catalog numbers available upon request.

TYPHOON PLUS™ 25150 (WITH HOLE OUTLET)

Catalog number **15745** - (any of below 6 digits)

FLOW RATE (L/H)	DISTANCE BETWEEN DRIPPERS (M)													
	0.15	0.20	0.25	0.30	0.35	0.40	0.50	0.60	0.65	0.70	0.75	0.80	0.90	1.00
0.50														
0.70														
1.00														
1.60														
2.20														
Carton coils length (m)	900	900	900	900	900	900	900	900	900	900	900	900	900	900

Missing catalog numbers available upon request.

DRIPPERLINES TECHNICAL DATA

MODEL	INSIDE DIAMETER (MM)	WALL THICKNESS (MM)	OUTSIDE DIAMETER (MM)	MAX. WORKING PRESSURE (BAR)	MAXIMUM FLUSHING PRESSURE (BAR)	KD
25150	25.00	0.38	25.76	1.4	1.6	0.01

DRIPPERLINES PACKAGE DATA (ON CARTON COILS)

MODEL	WALL THICKNESS (MM)	DISTANCE BETWEEN DRIPPERS (M)	COIL LENGTH (M)	AVERAGE* COIL WEIGHT (KG)	COILS PER PALLET (UNITS)	COILS IN A 40 FEET CONTAINER (UNITS)	TOTAL IN A 40 FEET CONTAINER (M)
25150	0.38	0.15 to 0.25	900	27.7	16	640	576000
		0.30 to 1.00	900	27.4			576000

*According to drippers spacing



STREAMLINE PLUS™

INTEGRAL DRIPPER

12060 - 12080 - 16055 - 16060 - 16080 - 22060 - 22070 - 22080

APPLICATIONS

Single season crops irrigation.

FEATURES AND BENEFITS

- Improved raw materials that achieve higher operating pressure and tensile strength for easier layout, and retrieval from the fields.
- Wide filtration area to ensure optimal performance.
- TurboNet™ labyrinth assures wide water passages, large deep and wide cross section improves clogging resistance.
- The water is drawn in to the dripper from the stream center, preventing the entrance of sediments in to the drippers. Injection molded dripper construction, ensuring uniform drippers and very low CV.
- Two orange stripes on the Streamline Plus™, which are clear and visible; show the dripper upward location in order to properly lay the laterals.

SPECIFICATIONS

- Recommended filtration: 130 micron / 120 mesh.
Filtration method is to be selected based on the kind and concentration of the dirt particles existing in the water. Wherever sand exceeding 2 ppm exists in the water, a Hydrocyclone is to be installed before the main filter. When sand/ silt/ clay solids exceed 100 ppm, pre treatment will be applied according to Netafim™ expert team's instructions.
- TurboNet™ labyrinth with large water passage.
- To be "welded" into a thin-walled dripperlines (0.14, 0.15, 0.18, 0.20 mm).
- Injected dripper, very low CV.
- UV resistant. Resistant to standard nutrients used in agricultural.
- Streamline Plus™ dripperlines meet ISO 9261 Standards with production certified by the Israel Standards Institute (SII).

DRIPPERS TECHNICAL DATA

0.14, 0.15, 0.18 mm wall thickness dripperlines

FLOW RATE* (L/H)	MAX. WORKING PRESSURE** (BAR)	WATER PASSAGES DIMENSIONS WIDTH-DEPTH-LENGTH (MM)	FILTRATION AREA (MM²)	CONSTANT K	EXPONENT X	RECOMMENDED FILTRATION (MICRON)/(MESH)
0.80	0.8/0.9/1.0/1.6	0.59 x 0.33 x 25	12	0.265	0.48	130/120
1.10		0.51 x 0.44 x 13	14	0.392	0.45	130/120
1.60		0.65 x 0.55 x 13	15	0.568	0.45	130/120
2.20		0.72 x 0.65 x 13	15	0.780	0.45	130/120
2.80		0.84 x 0.73 x 13	15	0.993	0.45	200/80

* Flow rate at 1.0 bar pressure **According to dripperlines wall thicknesses and inside diameters

0.20 mm wall thickness dripperlines

0.72	0.7/1.0/1.2/1.9	0.59 x 0.33 x 25	12	0.238	0.48	130/120
1.05		0.51 x 0.44 x 13	14	0.373	0.45	130/120
1.60		0.65 x 0.55 x 13	15	0.568	0.45	130/120
2.20		0.72 x 0.65 x 13	15	0.780	0.45	130/120
2.80		0.84 x 0.73 x 13	15	0.993	0.45	200/80

* Flow rate at 1.0 bar **According to dripperlines inside diameter

STREAMLINE PLUS™ 16055 (WITH FLAP OUTLET)

Catalog number **16220** - (any of below 6 digits)

FLOW RATE (L/H)	DISTANCE BETWEEN DRIPPERS (M)													
	0.15	0.20	0.25	0.30	0.35	0.40	0.50	0.60	0.65	0.70	0.75	0.80	0.90	1.00
0.80		001020		001070		001090								
1.10		003020		003065		003090								
1.60		005020		005045										
2.20														
2.80														
Carton coils length (m)	3200	3200	3200	3500	3500	3500	3500	3500	3500	3500	3500	3500	3500	3500

Missing catalog numbers available upon request.

STREAMLINE PLUS™ 16055 (WITH HOLE OUTLET)

Catalog number **16220** - (any of below 6 digits)

FLOW RATE (L/H)	DISTANCE BETWEEN DRIPPERS (M)													
	0.15	0.20	0.25	0.30	0.35	0.40	0.50	0.60	0.65	0.70	0.75	0.80	0.90	1.00
0.80	000001	001010		001060		001080								
1.10		003010		003060		003080								
1.60		005010		005040		005060								
2.20		006010		006030		006050								
2.80														
Carton coils length (m)	3200	3200	3200	3500	3500	3500	3500	3500	3500	3500	3500	3500	3500	3500

Missing catalog numbers available upon request.

DRIPPERLINES TECHNICAL DATA

MODEL	INSIDE DIAMETER (MM)	WALL THICKNESS (MM)	OUTSIDE DIAMETER (MM)	MAX. WORKING PRESSURE (BAR)	MAXIMUM FLUSHING PRESSURE (BAR)	KD
16055	16.20	0.14	16.48	0.9	1.0	0.10

DRIPPERLINES PACKAGE DATA (ON CARTON COILS)

MODEL	WALL THICKNESS (MM)	DISTANCE BETWEEN DRIPPERS (M)	COIL LENGTH (M)	AVERAGE* COIL WEIGHT (KG)	COILS PER PALLET (UNITS)	COILS IN A 40 FEET CONTAINER (UNITS)	TOTAL IN A 40 FEET CONTAINER (M)
16055	0.14	0.15 to 0.25	3200	24.5	16	640	2048000
		0.30 to 1.00	3500	25.6			2240000

*According to drippers spacing

STREAMLINE PLUS™ 16060 (WITH FLAP OUTLET)

Catalog number **16225** - (any of below 6 digits)

FLOW RATE (L/H)	DISTANCE BETWEEN DRIPPERS (M)													
	0.15	0.20	0.25	0.30	0.35	0.40	0.50	0.60	0.65	0.70	0.75	0.80	0.90	1.00
0.80		004990	000105	005010		005030	005040							
1.10	005190	005210		005230		005250	005260							
1.60	005954	005995		006000		006020								
2.20		007480		007500										
2.80														
Carton coils length (m)	2600	2600	2600	3000	3000	3000	3000	3000	3000	3000	3000	3000	3000	3000

Missing catalog numbers available upon request.

STREAMLINE PLUS™ 16060 (WITH HOLE OUTLET)

Catalog number **16225** - (any of below 6 digits)

FLOW RATE (L/H)	DISTANCE BETWEEN DRIPPERS (M)													
	0.15	0.20	0.25	0.30	0.35	0.40	0.50	0.60	0.65	0.70	0.75	0.80	0.90	1.00
0.80	000080	000101	000103	000111		000120		000175						
1.10	000490	000501	000506	000511		000520	000530							
1.60	000970	000990	000996	001010		001030		001060						
2.20		001990	001997	002010		002030								
2.80				000003										
Carton coils length (m)	2600	2600	2600	3000	3000	3000	3000	3000	3000	3000	3000	3000	3000	3000

Missing catalog numbers available upon request.

DRIPPERLINES TECHNICAL DATA

MODEL	INSIDE DIAMETER (MM)	WALL THICKNESS (MM)	OUTSIDE DIAMETER (MM)	MAX. WORKING PRESSURE (BAR)	MAXIMUM FLUSHING PRESSURE (BAR)	KD
16060	16.20	0.15	16.50	1.0	1.2	0.10

DRIPPERLINES PACKAGE DATA (ON CARTON COILS)

MODEL	WALL THICKNESS (MM)	DISTANCE BETWEEN DRIPPERS (M)	COIL LENGTH (M)	AVERAGE* COIL WEIGHT (KG)	COILS PER PALLET (UNITS)	COILS IN A 40 FEET CONTAINER (UNITS)	TOTAL IN A 40 FEET CONTAINER (M)
16060	0.15	0.15 to 0.25	2600	21.5	16	640	1664000
		0.30 to 1.00	3000	24.0			1920000

*According to drippers spacing

STREAMLINE PLUS™ 16080 (WITH FLAP OUTLET)

Catalog number **16230** - (any of below 6 digits)

FLOW RATE (L/H)	DISTANCE BETWEEN DRIPPERS (M)													
	0.15	0.20	0.25	0.30	0.35	0.40	0.50	0.60	0.65	0.70	0.75	0.80	0.90	1.00
0.72	003980	003995		004010		004040	004060							
1.05	004990	005010	005020	005060		005090	005110	005130						
1.60		005995		006000		006020								
2.20				007000		000008								
2.80														
Carton coils length (m)	2200	2200	2200	2500	2500	2500	2500	2500	2500	2500	2500	2500	2500	2500

Missing catalog numbers available upon request.

STREAMLINE PLUS™ 16080 (WITH HOLE OUTLET)

Catalog number **16230** - (any of below 6 digits)

FLOW RATE (L/H)	DISTANCE BETWEEN DRIPPERS (M)													
	0.15	0.20	0.25	0.30	0.35	0.40	0.50	0.60	0.65	0.70	0.75	0.80	0.90	1.00
0.72	000010	000002	000020	000004		000006		005140						
1.05	000098	000110	000115	000130		000150	000170					000190		000250
1.60	000990	001010	001030	001060	000007	001090	001110							
2.20	002470	002490	002496	002510		002530								
2.80				000012										
Carton coils length (m)	2200	2200	2200	2500	2500	2500	2500	2500	2500	2500	2500	2500	2500	2500

Missing catalog numbers available upon request.

DRIPPERLINES TECHNICAL DATA

MODEL	INSIDE DIAMETER (MM)	WALL THICKNESS (MM)	OUTSIDE DIAMETER (MM)	MAX. WORKING PRESSURE (BAR)	MAXIMUM FLUSHING PRESSURE (BAR)	KD
16080	16.20	0.20	16.60	1.2	1.4	0.10

DRIPPERLINES PACKAGE DATA (ON CARTON COILS)

MODEL	WALL THICKNESS (MM)	DISTANCE BETWEEN DRIPPERS (M)	COIL LENGTH (M)	AVERAGE* COIL WEIGHT (KG)	COILS PER PALLET (UNITS)	COILS IN A 40 FEET CONTAINER (UNITS)	TOTAL IN A 40 FEET CONTAINER (M)
16080	0.20	0.15 to 0.25	2200	23.7	16	640	1408000
		0.30 to 1.00	2500	26.3			1600000

*According to drippers spacing

STREAMLINE PLUS™ 22060 (WITH FLAP OUTLET)

Catalog number **16260** - (any of below 6 digits)

FLOW RATE (L/H)	DISTANCE BETWEEN DRIPPERS (M)													
	0.15	0.20	0.25	0.30	0.35	0.40	0.50	0.60	0.65	0.70	0.75	0.80	0.90	1.00
0.80		001030		001012										
1.10		002005		002015										
1.60														
2.20														
2.80														
Carton coils length (m)	2200	2200	2200	2400	2400	2400	2400	2400	2400	2400	2400	2400	2400	2400

Missing catalog numbers available upon request.

STREAMLINE PLUS™ 22060 (WITH HOLE OUTLET)

Catalog number **16260** - (any of below 6 digits)

FLOW RATE (L/H)	DISTANCE BETWEEN DRIPPERS (M)													
	0.15	0.20	0.25	0.30	0.35	0.40	0.50	0.60	0.65	0.70	0.75	0.80	0.90	1.00
0.80		001000		001010	001015	001020								
1.10		002000		002010		002020								
1.60			003035	003050		003060								
2.20				004000										
2.80														
Carton coils length (m)	2200	2200	2200	2400	2400	2400	2400	2400	2400	2400	2400	2400	2400	2400

Missing catalog numbers available upon request.

DRIPPERLINES TECHNICAL DATA

MODEL	INSIDE DIAMETER (MM)	WALL THICKNESS (MM)	OUTSIDE DIAMETER (MM)	MAX. WORKING PRESSURE (BAR)	MAXIMUM FLUSHING PRESSURE (BAR)	KD
22060	22.20	0.15	22.50	0.8	0.9	0.01

DRIPPERLINES PACKAGE DATA (ON CARTON COILS)

MODEL	WALL THICKNESS (MM)	DISTANCE BETWEEN DRIPPERS (M)	COIL LENGTH (M)	AVERAGE* COIL WEIGHT (KG)	COILS PER PALLET (UNITS)	COILS IN A 40 FEET CONTAINER (UNITS)	TOTAL IN A 40 FEET CONTAINER (M)
22060	0.15	0.15 to 0.25	2200	23.5	16	640	1408000
		0.30 to 1.00	2400	26.0			1536000

*According to drippers spacing

STREAMLINE PLUS™ 22080 (WITH FLAP OUTLET)

Catalog number **16270** - (any of below 6 digits)

FLOW RATE (L/H)	DISTANCE BETWEEN DRIPPERS (M)													
	0.15	0.20	0.25	0.30	0.35	0.40	0.50	0.60	0.65	0.70	0.75	0.80	0.90	1.00
0.72		004990	003860	005010		005020	005040							
1.05		005190	003950	005210		005230	005250							
1.60		006980		007000		007020								
2.20														
2.80														
Carton coils length (m)	1600	1600	1600	1800	1800	1800	1800	1800	1800	1800	1800	1800	1800	1800

Missing catalog numbers available upon request.

STREAMLINE PLUS™ 22080 (WITH HOLE OUTLET)

Catalog number **16270** - (any of below 6 digits)

FLOW RATE (L/H)	DISTANCE BETWEEN DRIPPERS (M)													
	0.15	0.20	0.25	0.30	0.35	0.40	0.50	0.60	0.65	0.70	0.75	0.80	0.90	1.00
0.72		000990		001010	001018	001030	001050	001070						
1.05		001990		002010		002030	002050							002150
1.60		002990		003010		003030	003045							
2.20		003990	003995	004010		004030								
2.80														
Carton coils length (m)	1600	1600	1600	1800	1800	1800	1800	1800	1800	1800	1800	1800	1800	1800

Missing catalog numbers available upon request.

DRIPPERLINES TECHNICAL DATA

MODEL	INSIDE DIAMETER (MM)	WALL THICKNESS (MM)	OUTSIDE DIAMETER (MM)	MAX. WORKING PRESSURE (BAR)	MAXIMUM FLUSHING PRESSURE (BAR)	KD
22080	22.20	0.20	22.60	1.0	1.2	0.01

DRIPPERLINES PACKAGE DATA (ON CARTON COILS)

MODEL	WALL THICKNESS (MM)	DISTANCE BETWEEN DRIPPERS (M)	COIL LENGTH (M)	AVERAGE* COIL WEIGHT (KG)	COILS PER PALLET (UNITS)	COILS IN A 40 FEET CONTAINER (UNITS)	TOTAL IN A 40 FEET CONTAINER (M)
22080	0.20	0.15 to 0.25	1600	23.6	16	640	1024000
		0.30 to 1.00	1800	25.6			1152000

*According to drippers spacing



MICRODRIP

INTEGRAL DRIPPER



APPLICATIONS

- Row crops irrigation (very short irrigation lines).
- Family Drip Systems.
- Nurseries & Kitchen gardens.

FEATURES AND BENEFITS

- TurboNet™ labyrinth assures wide water passages, large deep and wide cross section improves clogging resistance.
- Wide filtration area with improved resistance to clogging.
- Specifically suitable with short dripperline lengths are required.
- Injection molded dripper construction, ensuring uniform drippers and very low CV.

SPECIFICATIONS

- Recommended filtration: 130 micron / 120 mesh.
Filtration method is to be selected based on the kind and concentration of the dirt particles existing in the water. Wherever sand exceeding 2 ppm exists in the water, a Hydrocyclone is to be installed before the main filter. When sand/silt/ clay solids exceed 100 ppm, pre treatment will be applied according to Netafim™ expert team's instructions.
- TurboNet™ labyrinth with large water passage.
- To be "welded" into a medium-walled dripperline (0.80 mm).
- Injected dripper, very low CV.
- High UV resistant. Resistant to standard nutrients used in agricultural.
- Microdrip dripperlines meet ISO 9261 Standards with production certified by the Israel Standards Institute (SII).

DRIPPERS TECHNICAL DATA

FLOW RATE* (L/H)	MAXIMUM WORKING PRESSURE (BAR)	WATER PASSAGES DIMENSIONS WIDTH-DEPTH-LENGTH (MM)	FILTRATION AREA (MM ²)	CONSTANT K	EXPONENT X	RECOMMENDED FILTRATION (MICRON)/(MESH)
2.0	4.0	0.63 x 0.73 x 22	22	0.647	0.49	130/120

*Flow rate at 1.0 bar pressure

DRIPPERLINES TECHNICAL DATA

MODEL	INSIDE DIAMETER (MM)	WALL THICKNESS (MM)	OUTSIDE DIAMETER (MM)	MAX. WORKING PRESSURE (BAR)	KD
Microdrip	6.30	0.80	7.90	4.0	2.00

MICRODRIP

Catalog number **18500** - (any of below 6 digits)

FLOW RATE (L/H)	DISTANCE BETWEEN DRIPPERS (METER)	COIL LENGTH (METER)				
		200	250	300	400	600
2.00	0.2			002897		
2.00	0.3	002948	002950	003000	003001	003003
2.00	0.4					

Missing catalog numbers available upon request.

Blank dripperline, without drippers inside, 300 meter coil: 18500-000970

DRIPPERLINES PACKAGE DATA (ON BUNDLED COILS)

WALL THICKNESS (MM)	COIL LENGTH (M)	DISTANCE BETWEEN DRIPPERS (M)	AVERAGE COIL WEIGHT (KG)	COILS IN A 40 FEET CONTAINER (UNITS)	TOTAL IN A 40 FEET CONTAINER (M)
0.80	200	0.20 to 0.40	3.5	1440	288000
0.80	250	0.20 to 0.40	4.3	1440	360000
0.80	300	0.20 to 0.40	5.2	1440	432000
0.80	400	0.20 to 0.40	6.9	640	256000
0.80	600	0.20 to 0.40	10.4	640	384000



PC DRIPPER

ON-LINE PRESSURE-COMPENSATING,
CONTINUOUSLY SELF-CLEANING DRIPPER



APPLICATIONS

- Greenhouses, nurseries, citrus.
- Orchards, deciduous and tree irrigation.

FEATURES AND BENEFITS

- Pressure compensated: Precise and equal amounts of water are delivered over a broad pressure range. 100% uniformity of water and nutrient distribution along the laterals.
- PC-LCNL & PC-HCNL with Anti-drain (LCNL & HCNL): Eliminates drainage and refill effect, and improves efficiency in pulse irrigation.
- Continuously self flushing: continuously flushing debris, throughout operation, not just at the beginning or end of a cycle, ensuring uninterrupted dripper operation.
- TurboNet™ labyrinth assures wide water passages, large deep and wide cross section improves clogging resistance.
- Dripper can be positioned exactly where required.
- Number of drippers can be increased so as to increase water quantity supply aimed at meeting tree growth rate requirement.
- Allows the installation of "spider assembly," splitting the drip supply into a number of drip outlets.

SPECIFICATIONS

- Recommended filtration: 130 micron / 120 mesh.
Filtration method is to be selected based on the kind and concentration of the dirt particles existing in the water. Wherever sand exceeding 2 ppm exists in the water, a Hydrocyclone is to be installed before the main filter. When sand/silt/clay solids exceed 100 ppm, pre treatment will be applied according to Netafim™ expert team's instructions.
- TurboNet™ labyrinth with large water passage.
- To be "inserted" into thick-walled pipes (0.90, 1.00, 1.20 mm)
- Injected dripper, very low CV.
- High UV resistant. Resistant to standard nutrients used in agricultural.
- PC on-line drippers meet ISO 9261 Standards with production certified by the Israel Standards Institute (SII).

DRIPPERS TECHNICAL DATA

PC drippers

FLOW RATE* (L/H)	WORKING PRESSURE RANGE (BAR)	WATER PASSAGES DIMENSIONS WIDTH-DEPTH-LENGTH (MM)	FILTRATION AREA (MM ²)	CONSTANT K	EXPONENT* X	BASE CODE COLOR	CAP COLOR CODE
2.0	0.5 – 4.0	1.17 x 1.07 x 61	2.0	2.0	0	Red	Black
4.0	0.5 – 4.0	1.32 x 1.44 x 60	2.0	4.0	0	Black	Black
8.5	0.5 – 4.0	1.60 x 1.60 x 17	2.0	8.5	0	Green	Black

*Within working pressure range

PC-LCNL drippers

FLOW RATE* (L/H)	WORKING PRESSURE RANGE (BAR)	WATER PASSAGES DIMENSIONS WIDTH-DEPTH-LENGTH (MM)	FILTRATION AREA (MM ²)	CONSTANT K	EXPONENT* X	SHUT OFF PRESSURE (BAR)	BASE CODE COLOR	CAP COLOR CODE
2.0	1.0 – 4.0	1.17 x 1.07 x 61	2.0	2.0	0	0.15	Red	Brown
4.0	1.0 – 4.0	1.32 x 1.44 x 60	2.0	4.0	0	0.15	Black	Brown
8.5	1.0 – 4.0	1.60 x 1.60 x 17	2.0	8.5	0	0.15	Green	Brown

* Within working pressure range

PC-HCNL drippers

FLOW RATE* (L/H)	WORKING PRESSURE RANGE (BAR)	WATER PASSAGES DIMENSIONS WIDTH-DEPTH-LENGTH (MM)	FILTRATION AREA (MM ²)	CONSTANT K	EXPONENT* X	SHUT OFF PRESSURE (BAR)	BASE CODE COLOR	CAP COLOR CODE
3.0	1.4 – 4.0	1.17 x 1.07 x 61	2.0	3.0	0	0.30	Black	Black
6.0	1.4 – 4.0	1.32 x 1.44 x 60	2.0	6.0	0	0.30	Black	Black
12.0	1.4 – 4.0	1.60 x 1.60 x 17	2.0	12.0	0	0.30	Black	Black

* Within working pressure range



PC DRIPPER FLAT MODEL



PC DRIPPER NIPPLE MODEL

PC DRIPPER FLAT MODEL

Catalog number **21000** - (any of below 6 digits)

FLOW RATE (L/H)	1 UNIT	25 UNITS/BAG	50 UNITS/BAG	100 UNITS/BAG	250 UNITS/BAG	500 UNITS/BAG	1000 UNITS/BAG	2500 UNITS/CARTON
2.0	001000		001020	001030	001033	001035	001040	001051
4.0	001100		001120	001130	001133	001135	001140	001151
8.5	001200		001220	001230	001233	001235	001240	001246

Missing catalog numbers available upon request

PC DRIPPER NIPPLE MODEL

Catalog number **21020** - (any of below 6 digits)

FLOW RATE (L/H)	1 UNIT	25 UNITS/BAG	50 UNITS/BAG	100 UNITS/BAG	250 UNITS/BAG	500 UNITS/BAG	1000 UNITS/BAG	2500 UNITS/CARTON
2.0	001000		001020	001030	001033	001035	001040	001051
4.0	001100	001110	001120	001130	001133	001135	001141	001149
8.5	001200	001210	001220	001230	001235	001232	001240	001251

Missing catalog numbers available upon request

PC DRIPPER NIPPLE MODEL

Catalog number **21000** - (any of below 6 digits)

FLOW RATE (L/H)	1 UNIT	25 UNITS/BAG	50 UNITS/BAG	100 UNITS/BAG	250 UNITS/BAG	500 UNITS/BAG	1000 UNITS/BAG	2300 UNITS/CARTON
25.0	001400	001410	001420	001430	001440			
25.0 + cap ass.	001300		001320	001330	001340	001350	001390	001360

Missing catalog numbers available upon request

PC - LCNL DRIPPER FLAT MODEL

Catalog number **21000** - (any of below 6 digits)

FLOW RATE (L/H)	1 UNIT	25 UNITS/BAG	50 UNITS/BAG	100 UNITS/BAG	250 UNITS/BAG	500 UNITS/BAG	1000 UNITS/CARTON	2500 UNITS/CARTON
2.0	001500	001510	001520	001530	001540			
4.0	001600	001610	001620	001630	001640			
8.5	001700	001710	001720	001730	001740	001750		

Missing catalog numbers available upon request

PC - LCNL DRIPPER NIPPLE MODEL

Catalog number **21020** - (any of below 6 digits)

FLOW RATE (L/H)	1 UNIT	25 UNITS/BAG	50 UNITS/BAG	100 UNITS/BAG	250 UNITS/BAG	500 UNITS/BAG	1000 UNITS/CARTON	2500 UNITS/CARTON
2.0	001300	001315	001320	001330	001333	001335	001341	001061
4.0	001400	001410	001420	001430	001433	001435	001441	001156
8.5	001500	001510	001520	001530	001533	001535	001545	001201

PC - HCNL DRIPPER NIPPLE MODEL

Catalog number **21060** - (any of below 6 digits)

FLOW RATE (L/H)	1 UNIT	25 UNITS/BAG	50 UNITS/BAG	100 UNITS/BAG	250 UNITS/BAG	500 UNITS/BAG	1000 UNITS/CARTON	2500 UNITS/CARTON
3.0	001000		001020	001022	001030		001040	
6.0	001200		001210	001220			001240	
12.0	001300		001320	001330	001335		001340	

Missing catalog numbers available upon request

PACKAGE DATA

	QUANTITY P/BOX UNITS	BOX DIMENSIONS (CM X CM X CM)	BOX WEIGHT (KG)
PC & PC-LCNL drippers , flat model	2500	57 x 28 x 27	18
PC , PC-LCNL & PC-HCNL drippers , nipple model	2500	57 x 28 x 27	19





PCJ DRIPPER

COMPACT ON-LINE PRESSURE-COMPENSATING,
CONTINUOUSLY SELF-CLEANING DRIPPER



APPLICATIONS

- Greenhouses, nurseries, citrus.
- Orchards, deciduous and tree irrigation.

FEATURES AND BENEFITS

- Pressure compensated: Precise and equal amounts of water are delivered over a broad pressure range. 100% uniformity of water and nutrient distribution along the laterals.
- PCJ-LCNL & PCJ-HCNL with Anti-drain (LCNL & HCNL): Eliminates drainage and refill effect, and improves efficiency in pulse irrigation.
- Continuously self flushing: Continuously flushing debris, throughout operation, not just at the beginning or end of a cycle, ensuring uninterrupted dripper operation.
- TurboNet™ labyrinth assures wide water passages, large deep and wide cross section improves clogging resistance.
- Dripper can be positioned exactly where required.
- Number of drippers can be increased so as to increase water quantity supply aimed at meeting tree growth rate requirement.
- Allows the installation of "spider assembly," splitting the drip supply into a number of drip outlets.

SPECIFICATIONS

- Recommended filtration: 130 micron / 120 mesh.
Filtration method is to be selected based on the kind and concentration of the dirt particles existing in the water. Wherever sand exceeding 2 ppm exists in the water, a Hydrocyclone is to be installed before the main filter. When sand/silt/clay solids exceed 100 ppm, pre treatment will be applied according to Netafim™ expert team's instructions.
- TurboNet™ labyrinth with large water passage.
- To be "inserted" into thick-walled pipes (0.90, 1.00, 1.20 mm)
- Injected dripper, very low CV.
- 3 different outlets: nipple, barb to 3 mm ID and barb to 4 mm ID micro-tube.
- High UV resistant. Resistant to standard nutrients used in agricultural.
- PCJ on-line drippers meet ISO 9261 Standards with production certified by the Israel Standards Institute (SII).

DRIPPERS TECHNICAL DATA

PCJ drippers

FLOW RATE* (L/H)	WORKING PRESSURE RANGE (BAR)	WATER PASSAGES DIMENSIONS WIDTH-DEPTH-LENGTH (MM)	FILTRATION AREA (MM²)	CONSTANT K	EXPONENT* X	BASE CODE COLOR	CAP COLOR CODE
0.5	0.5 – 4.0	0.54 x 0.60 x 35	1.8	0.5	0	Mustard	Black
1.2	0.5 – 4.0	0.67 x 0.77 x 35	2.0	1.2	0	Brown	Black
2.0	0.5 – 4.0	0.98 x 0.79 x 35	2.0	2.0	0	Red	Black
3.0	0.5 – 4.0	1.03 x 1.07 x 35	2.0	3.0	0	Blue	Black
4.0	0.5 – 4.0	1.32 x 0.92 x 35	2.0	4.0	0	Gray	Black
8.0	0.5 – 4.0	1.60 x 1.08 x 35	2.0	8.0	0	Green	Black
12.0	0.5 – 4.0	1.60 x 1.08 x 17	2.0	12.0	0	Fuchsia	Black
15.0	0.5 – 4.0	1.60 x 1.08 x 17	2.0	15.0	0	Black	Black

*Within working pressure range

PCJ-LCNL drippers

FLOW RATE* (L/H)	WORKING PRESSURE RANGE (BAR)	WATER PASSAGES DIMENSIONS WIDTH-DEPTH-LENGTH (MM)	FILTRATION AREA (MM²)	CONSTANT K	EXPONENT* X	SHUT OFF PRESSURE (BAR)	BASE CODE COLOR**	CAP COLOR CODE
0.5	0.7 – 4.0	0.54 x 0.60 x 35	1.8	0.5	0	0.12	Mustard	Black
1.2	0.7 – 4.0	0.67 x 0.77 x 35	2.0	1.2	0	0.12	Brown	Black
2.0	0.7 – 4.0	0.98 x 0.79 x 35	2.0	2.0	0	0.12	Red	Black
3.0	0.7 – 4.0	1.03 x 1.07 x 35	2.0	3.0	0	0.12	Blue	Black
4.0	0.7 – 4.0	1.32 x 0.92 x 35	2.0	4.0	0	0.12	Gray	Black
8.0	0.7 – 4.0	1.60 x 1.08 x 35	2.0	8.0	0	0.12	Green	Black
12.0	0.7 – 4.0	1.60 x 1.08 x 17	2.0	12.0	0	0.12	Fuchsia	Black
15.0	0.7 – 4.0	1.60 x 1.08 x 17	2.0	15.0	0	0.12	Black	Black

*Within working pressure range **PCJ-LCNL is distinguished by the rings around the barb water inlet connector

PCJ-HCNL drippers

FLOW RATE* (L/H)	WORKING PRESSURE RANGE (BAR)	WATER PASSAGES DIMENSIONS WIDTH-DEPTH-LENGTH (MM)	FILTRATION AREA (MM²)	CONSTANT K	EXPONENT* X	SHUT OFF PRESSURE (BAR)	BASE CODE COLOR	CAP COLOR CODE
0.5	1.5 – 4.0	0.54 x 0.60 x 35	1.8	0.5	0	0.18	Light yellow	Black
1.2	1.5 – 4.0	0.67 x 0.77 x 35	2.0	1.2	0	0.18	Light brown	Black
2.0	1.5 – 4.0	0.98 x 0.79 x 35	2.0	2.0	0	0.18	Pink	Black
3.0	1.5 – 4.0	1.03 x 1.07 x 35	2.0	3.0	0	0.18	Light blue	Black
4.0	1.5 – 4.0	1.32 x 0.92 x 35	2.0	4.0	0	0.18	Light gray	Black

*Within working pressure range



PCJ DRIPPER NIPPLE MODEL



PCJ DRIPPER 4 MM BARB MODEL



PCJ DRIPPER 3 MM BARB MODEL

PCJ DRIPPER 3 MM BARB OUTLET

Catalog number **21500** - (any of below 6 digits)

FLOW RATE (L/H)	1 UNIT	10 UNITS/BAG	25 UNITS/BAG	50 UNITS/BAG	100 UNITS/BAG	250 UNITS/BAG	500 UNITS/BAG	1000 UNITS/BAG	13000 UNITS/BOX
0.5	000700	000710			000730			000740	
1.2	000800	000805		000815				000840	
2.0	001000	001005	001010	001020	001030	001035		001040	001041
3.0	001150	001152		001155				001159	
4.0	001200	001205	001210	001220	001230	001233	001235	001240	
8.0	001400	001405	001410	001420	001430	001440		001450	
12.0	001470	001475			001480			001495	
15.0	003010							003030	

Missing catalog numbers available upon request

PCJ DRIPPER - WITH AI (ANTI-INSECTS) ASSEMBLY CAP

Catalog number **21500** - (any of below 6 digits)

FLOW RATE (L/H)	1 UNIT
2.0	004300
3.0	004310
4.0	004320
8.0	004330



PCJ DRIPPER WITH AI ASSEMBLY CAP

PCJ DRIPPER 4 MM BARB OUTLET

Catalog number **21500** - (any of below 6 digits)

FLOW RATE (L/H)	1 UNIT	10 UNITS/BAG	25 UNITS/BAG	50 UNITS/BAG	100 UNITS/BAG	250 UNITS/BAG	500 UNITS/BAG	1000 UNITS/BAG	12000 UNITS/BOX
0.5	001580					001585			
1.2	001600								
2.0	001700								
3.0	001900								
4.0	002100								
8.0	002300								
12.0	002400					002440			
15.0	003020					003040			

Missing catalog numbers available upon request

PCJ DRIPPER NIPPLE OUTLET

Catalog number **21500** - (any of below 6 digits)

FLOW RATE (L/H)	1 UNIT	10 UNITS/BAG	25 UNITS/BAG	50 UNITS/BAG	100 UNITS/BAG	250 UNITS/BAG	500 UNITS/BAG	1000 UNITS/BAG	12000 UNITS/BOX
0.5	001042	001045		001046					
1.2	001050	001057		001060				001090	
2.0	001100	001110	001112	001115	001130	001140		001145	
3.0	001160							001190	
4.0	001300	001310	001315	001320	001330			001340	
8.0	001500	001510		001520	001530	001535		001540	
12.0	001560	001561		001562	001565			001575	
15.0	003400							003450	

Missing catalog numbers available upon request

PCJ-LCNL DRIPPER 3 MM BARB OUTLET

Catalog number **21520** - (any of below 6 digits)

FLOW RATE (L/H)	1 UNIT	10 UNITS/BAG	25 UNITS/BAG	50 UNITS/BAG	100 UNITS/ BAG	250 UNITS/ BAG	500 UNITS/ BAG	1000 UNITS/BAG	13000 UNITS/BOX
0.5	000810				000820			000840	
1.2	000900			000910	000920	000930		000940	000950
2.0	001000		001015	001020	001030	001040		001050	001051
3.0	001200			001210	001220	001230		001240	001250
4.0	001400		001410	001420	001430	001440	001445	001450	001460
8.0	001600		001610	001620	001630	001640		001650	001660
12.0	001670		001680	001685	001687	001690		001695	001698

Missing catalog numbers available upon request

PCJ-LCNL DRIPPER 4 MM BARB OUTLET

Catalog number **21520** - (any of below 6 digits)

FLOW RATE (L/H)	1 UNIT	10 UNITS/BAG	25 UNITS/BAG	50 UNITS/BAG	100 UNITS/ BAG	250 UNITS/ BAG	500 UNITS/ BAG	1000 UNITS/BAG	12000 UNITS/BOX
0.5	002850								
1.2	002900								
2.0	003000		003020		003030	003040		003060	003070
3.0	003200								
4.0	003400		003420		003430	003440		003460	
8.0	003600		003620	003625	003630	003640		003660	
12.0	003700								

Missing catalog numbers available upon request

PCJ-LCNL DRIPPER NIPPLE OUTLET

Catalog number **21520** - (any of below 6 digits)

FLOW RATE (L/H)	1 UNIT	10 UNITS/BAG	25 UNITS/BAG	50 UNITS/BAG	100 UNITS/ BAG	250 UNITS/ BAG	500 UNITS/ BAG	1000 UNITS/BAG	12000 UNITS/BOX
0.5	001052								
1.2	001060							001090	
2.0	001100			001120	001130	001140		001150	001155
3.0	001300			001310	001320			001340	
4.0	001500		001510	001520	001530	001540		001550	001560
8.0	001700		001710	001720	001730	001740		001750	001760
12.0	001770			001775		001780		001795	

Missing catalog numbers available upon request

PCJ-HCNL DRIPPER 3 MM BARB OUTLET

Catalog number **21520** - (any of below 6 digits)

FLOW RATE (L/H)	1 UNIT	10 UNITS/BAG	25 UNITS/BAG	50 UNITS/BAG	100 UNITS/BAG	250 UNITS/BAG	500 UNITS/BAG	1000 UNITS/BAG	13000 UNITS/BOX
0.5	003870							003890	
1.2	004100		004120			004130		004150	
2.0	004400			004410				004440	004450
3.0	004700			004710				004740	
4.0	005000			005010				005040	

Missing catalog numbers available upon request

PCJ-HCNL DRIPPER 4 MM BARB OUTLET

Catalog number **21520** - (any of below 6 digits)

FLOW RATE (L/H)	1 UNIT	10 UNITS/BAG	25 UNITS/BAG	50 UNITS/BAG	100 UNITS/BAG	250 UNITS/BAG	500 UNITS/BAG	1000 UNITS/BAG	12000 UNITS/BOX
0.5	003900								
1.2	004220								
2.0	004500								
3.0	004800								
4.0	005100								

Missing catalog numbers available upon request

PCJ-HCNL DRIPPER NIPPLE OUTLET

Catalog number **21520** - (any of below 6 digits)

FLOW RATE (L/H)	1 UNIT	10 UNITS/BAG	25 UNITS/BAG	50 UNITS/BAG	100 UNITS/BAG	250 UNITS/BAG	500 UNITS/BAG	1000 UNITS/BAG	12000 UNITS/BOX
0.5	003850								
1.2	004000							004040	
2.0	004300							004350	
3.0	004600							004640	
4.0	004900							004950	

Missing catalog numbers available upon request

PACKAGE DATA

	QUANTITY P/BOX UNITS	BOX DIMENSIONS (CM X CM X CM)	AVERAGE BOX WEIGHT (KG)
PCJ drippers (all the models)	According to drippers model	57 x 28 x 27	14.0





PCJ - HF ON-LINE BUBBLERS

ON-LINE COMPACT PRESSURE COMPENSATED BUBBLER



APPLICATIONS

Landscape, trees and fruit trees with large treetops.

FEATURES AND BENEFITS

- Wide water passages, improves clogging resistance.
- PC system, patented pressure differential system maintains uniform flow rate at different inlet working pressure (in the recommended working pressure range), ensuring exact distribution of the water and nutrients.
- Continuous self-flushing system, improves resistance to clogging.
- Anti drain (CNL) system, optional model, eliminates drainage and refill effect, improves efficiency in pulse irrigation.
- Number of emitters can be increased so as to increase water quantity supply aimed at meeting tree growth rate requirement.
- Allows the installation of "spider assembly," splitting the water supply to a number of outlets and/or PC spray stake units.

SPECIFICATIONS

- Working pressure: 1.0 to 4.0 bar (1.3 to 4.0 bar in the 40 l/h).
- Large water passages.
- Recommended filtration: 130 micron / 120 mesh.
Filtration method is to be selected based on the kind and concentration of the dirt particles existing in the water. Wherever sand exceeding 2 ppm exists in the water, a Hydrocyclone is to be installed before the main filter. When sand/silt/clay solids exceed 100 ppm, pre treatment will be applied according to Netafim™ expert team's instructions.
- 5 different flow rates.
- 3 different outlets: nipple, barb to 3 mm ID and barb to 4 mm ID. micro-tube.
- To be "inserted" into thick-walled pipes (0.90, 1.00, 1.20 mm).
- Injected emitter, very low CV.
- Injected silicon diaphragm.

BUBBLER TECHNICAL DATA

PCJ-HF bubblers

FLOW RATE* (L/H)	WORKING PRESSURE RANGE (BAR)	FILTRATION AREA (MM ²)	CONSTANT K	EXPONENT* X	BASIS CODE COLOR	CAP COLOR CODE
20	1.0 – 4.0	2.0	20	0	Orange	Black
25	1.0 – 4.0	2.0	25	0	Orange	Light brown
30	1.0 – 4.0	2.0	30	0	Orange	Brown
35	1.0 – 4.0	2.0	35	0	Orange	Light blue
40	1.3 – 4.0	2.0	40	0	Orange	Blue

*Within working pressure range

PCJ-HF-CNL bubblers

FLOW RATE* (L/H)	WORKING PRESSURE RANGE (BAR)	FILTRATION AREA (MM ²)	CONSTANT K	EXPONENT* X	SHUT OFF PRESSURE (BAR)	BASIS CODE COLOR**	CAP COLOR CODE
20	1.0 – 4.0	2.0	20	0	0.12	Orange	Black
25	1.0 – 4.0	2.0	25	0	0.12	Orange	Light brown
30	1.0 – 4.0	2.0	30	0	0.12	Orange	Brown
35	1.0 – 4.0	2.0	35	0	0.12	Orange	Light blue
40	1.3 – 4.0	2.0	40	0	0.12	Orange	Blue

*Within working pressure range **CNL bubblers is distinguished by the rings around the inlet barb connector

PCJ-HF BUBBLER - NIPPLE OUTLET

Catalog number **21620** - (any of below 6 digits)

FLOW RATE (L/H)	1 UNIT	100 UNITS/BAG
20.0	001250	
25.0	001550	001560
30.0	001750	001770
35.0	001950	001960
40.0	002150	002170

Missing catalog numbers available upon request

PCJ-HF BUBBLER - 3MM BARB OUTLET

Catalog number **21620** - (any of below 6 digits)

FLOW RATE (L/H)	1 UNIT	100 UNITS/BAG
20.0	001200	001220
25.0	001500	
30.0	001700	001710
35.0	001900	
40.0	002100	

Missing catalog numbers available upon request

PCJ-HF BUBBLER - 4MM BARB OUTLET

Catalog number **21620** - (any of below 6 digits)

FLOW RATE (L/H)	1 UNIT	100 UNITS/BAG
20.0	001350	
25.0	001650	
30.0	001850	
35.0	002050	
40.0	002250	

Missing catalog numbers available upon request

PCJ-HF BUBBLER NIPPLE OUTLET + ASSEMBLY CAP

Catalog number **21620** - (any of below 6 digits)

FLOW RATE (L/H)	1 UNIT	50 UNITS/BAG	100 UNITS/BAG	500 UNITS/BAG	1000 UNITS/BAG
20.0	001300	001310	001315	001320	001340
25.0	001600		001610	001620	001640
30.0	001800		001810	001820	001840
35.0	002000		002010	002020	002040
40.0	002200		002210	002220	

Missing catalog numbers available upon request

PCJ-HF-BUBBLER WITH ASSEMBLY CAP

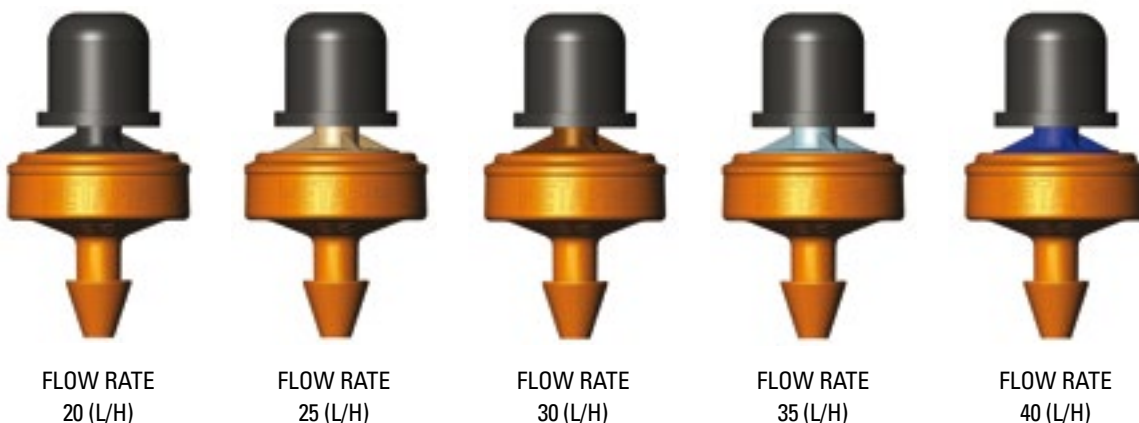

PCJ-HF-CNL BUBBLER - NIPPLE OUTLET

Catalog number **21630** - (any of below 6 digits)

FLOW RATE (L/H)	1 UNIT	100 UNITS/BAG
20.0	002150	001260
25.0	001550	
30.0	001750	001760
35.0	001950	
40.0	002150	002160

Missing catalog numbers available upon request

PCJ-HF-CNL BUBBLER - 3MM BARB OUTLET

Catalog number **21630** - (any of below 6 digits)

FLOW RATE (L/H)	1 UNIT	100 UNITS/BAG
20.0	001200	001220
25.0	001500	001510
30.0	001700	001710
35.0	001900	001920
40.0	002100	002130

PCJ-HF-CNL BUBBLER - 4MM BARB OUTLET

Catalog number **21630** - (any of below 6 digits)

FLOW RATE (L/H)	1 UNIT	100 UNITS/BAG
20.0	001350	
25.0	001650	
30.0	001850	
35.0	002050	
40.0	002250	

Missing catalog numbers available upon request

PCJ-HF- CNL BUBBLER NIPPLE OUTLET + ASSEMBLY CAP

Catalog number **21630** - (any of below 6 digits)

FLOW RATE (L/H)	1 UNIT	50 UNITS/BAG	100 UNITS/BAG	500 UNITS/BAG	1000 UNITS/BAG
20.0	001270	001280		001300	
25.0	001570	001580		001600	
30.0	001860	001870		001880	
35.0	002060			002080	
40.0	002300	002310		002320	

Missing catalog numbers available upon request

PACKAGE DATA

	QUANTITY P/BOX UNITS	BOX DIMENSIONS (CM X CM X CM)	AVERAGE BOX WEIGHT (KG)
PCJ-HF bubblers	According to bubblers model	57 x 28 x 27	14.0





BUTTON & POT DRIPPER

ON-LINE DRIPPER



APPLICATIONS

- Greenhouses, nurseries, garden pots.

FEATURES AND BENEFITS

- TurboNet™ labyrinth assures wide water passages, large deep and wide cross section improves clogging resistance.
- Dripper can be positioned exactly where required.
- Number of drippers can be increased to increase the water quantities applied aimed at meeting tree's growth rate requirements.
- Allows the installation of "spider assembly," splitting the drip supply to a number of drip outlets.

SPECIFICATIONS

- Maximal working pressure: 2.0 bar.
- TurboNet™ labyrinth with large water passages.
- Recommended filtration: 130 micron / 120 mesh.
Filtration method is to be selected based on the kind and concentration of the dirt particles existing in the water. Wherever sand exceeding 2 ppm exists in the water, a Hydrocyclone is to be installed before the main filter. When sand/ silt/ clay solids exceed 100 ppm, pre treatment will be applied according to Netafim™ expert team's instructions.
- 4 different flow rates.
- The Button model to be inserted into a thick-walled pipe (0.90, 1.00, 1.20 mm).
- The Pot model to be threaded into a 3*5 mm micro-tube.
- Injected dripper, very low CV.

DRIPPERS TECHNICAL DATA

Button drippers

FLOW RATE* (L/H)	MAXIMUM WORKING PRESSURE (BAR)	WATER PASSAGES DIMENSIONS WIDTH-DEPTH-LENGTH (MM)	CONSTANT K	EXPONENT X	BASIS CODE COLOR	CAP COLOR CODE
2.00	2.0	0.98 x 0.89 x 50	0.662	0.48	Red	Black
3.00	2.0	1.05 x 0.95 x 50	0.993	0.48	Blue	Black
4.00	2.0	1.27 x 1.20 x 50	1.325	0.48	Black	Black
8.00	2.0	1.65 x 1.40 x 50	2.649	0.48	Green	Black

*Flow rate at 1.0 bar pressure

Pot drippers

FLOW RATE* (L/H)	MAXIMUM WORKING PRESSURE (BAR)	WATER PASSAGES DIMENSIONS WIDTH-DEPTH-LENGTH (MM)	CONSTANT K	EXPONENT X	BASIS CODE COLOR	CAP COLOR CODE
2.00	2.0	0.98 x 0.89 x 50	0.662	0.48	Red	Black
4.00	2.0	1.27 x 1.20 x 50	1.325	0.48	Black	Black
8.00	2.0	1.65 x 1.40 x 50	2.649	0.48	Green	Black

*Flow rate at 1.0 bar pressure

BUTTON DRIPPER FLAT OUTLET

Catalog number **20000** - (any of below 6 digits)

FLOW RATE (L/H)	1 UNIT	10 UNITS/BAG	25 UNITS/BAG	50 UNITS/BAG	100 UNITS/BAG	250 UNITS/BAG	1000 UNITS/BAG	10000 UNITS/BOX
2.00	001100	001110	001115	001120	001140	001143	001145	001048
3.00	001150						001195	
4.00	001200	001210	001215	001220	001230	001235	001240	001250
8.00	001300	001310	001315	001320	001330	001333	001335	001350

Missing catalog numbers available upon request

PACKAGE DATA

	QUANTITY P/BOX UNITS	BOX DIMENSIONS (CM X CM X CM)	BOX WEIGHT (KG)
Flat outlet	10000	57 x 28 x 27	12.7

BUTTON DRIPPER BARB OUTLET

Catalog number **20020** - (any of below 6 digits)

FLOW RATE (L/H)	1 UNIT	10 UNITS/BAG	25 UNITS/BAG	50 UNITS/BAG	100 UNITS/BAG	250 UNITS/BAG	1000 UNITS/BAG	9500 UNITS/BOX
2.00	001500	001510	001515	001520	001530	001535	001540	001545
3.00	001550			001570			001595	
4.00	001600	001610	001615	001620	001630	001635	001640	001650
8.00	001700	001710	001715	001720	001730	001735	001740	001750

Missing catalog numbers available upon request

PACKAGE DATA

	QUANTITY P/BOX UNITS	BOX DIMENSIONS (CM X CM X CM)	BOX WEIGHT (KG)
Barb outlet	9500	57 x 28 x 27	12.4

BUTTON DRIPPER NIPPLE OUTLET

Catalog number **20020** - (any of below 6 digits)

FLOW RATE (L/H)	1 UNIT	10 UNITS/BAG	25 UNITS/BAG	50 UNITS/BAG	100 UNITS/BAG	250 UNITS/BAG	1000 UNITS/BAG	9500 UNITS/BOX
2.00	001100			001110	001130		001140	
3.00	001150							
4.00	001200			001220	001230		001240	
8.00	001300			001320	001330		001340	

Missing catalog numbers available upon request

PACKAGE DATA

	QUANTITY P/BOX UNITS	BOX DIMENSIONS (CM X CM X CM)	BOX WEIGHT (KG)
Nipple outlet	8500	57 x 28 x 27	11.2

POT DRIPPER FLAT OUTLET

Catalog number **20500** - (any of below 6 digits)

FLOW RATE (L/H)	1 UNIT	10 UNITS/BAG	20 UNITS/BAG	50 UNITS/BAG	100 UNITS/BAG	250 UNITS/BAG	1000 UNITS/BAG
2.00	001100	001110	001115	001120	001130		001140
4.00	001200	001210		001220	001230		001240
8.00	001300	001310		001320	001330		001340

Missing catalog numbers available upon request

PACKAGE DATA

	QUANTITY P/BOX UNITS	BOX DIMENSIONS (CM X CM X CM)	BOX WEIGHT (KG)
Flat outlet	10000	57 x 28 x 27	12.8

POT DRIPPER NIPPLE OUTLET

Catalog number **20520** - (any of below 6 digits)

FLOW RATE (L/H)	1 UNIT	10 UNITS/BAG	20 UNITS/BAG	50 UNITS/BAG	100 UNITS/BAG	250 UNITS/BAG	1000 UNITS/BAG
2.00	001100	001110		001120	001130	001140	
4.00	001200	001210		001220	001230	001240	
8.00	001300	001310		001320	001330		001340

Missing catalog numbers available upon request

PACKAGE DATA

	QUANTITY P/BOX UNITS	BOX DIMENSIONS (CM X CM X CM)	BOX WEIGHT (KG)
Nipple outlet	8500	57 x 28 x 27	11.3

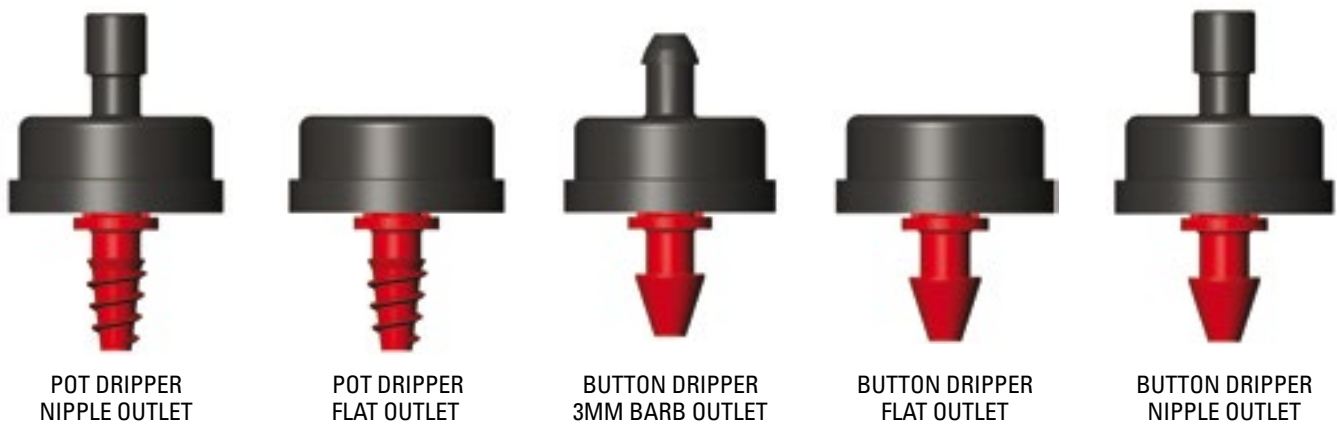





ARROW DRIPPER

APPLICATIONS

- Greenhouses, nurseries, garden pot irrigation.

FEATURES AND BENEFITS

- Allows placement of drippers exactly where necessary.
- Allows maximum flexibility in greenhouse and nurseries (with soft PE micro- tubes).
- Allows installation of other Netafim™ drippers to add compensated and anti-drain functionality.
- Accessory to all on-line drippers for better and more accurate installation.
- Adaptable to all on-line drippers via barb, manifold or adapter.

SPECIFICATIONS

- Maximal working pressure: 2.0 bar.
- “Turbulent” labyrinth wide water passages for highest reliability and efficiency.
- Recommended filtration: 130 micron / 120 mesh.
Filtration method is to be selected based on the kind and concentration of the dirt particles existing in the water. Wherever sand exceeding 2 ppm exists in the water, a Hydrocyclone is to be installed before the main filter. When sand/silt/clay solids exceed 100 ppm, pre treatment will be applied according to Netafim™ expert team’s instructions.
- 5 different models to meet growers’ requirements.
- To be “inserted” into a 3*5 mm micro-tube.
- Injected dripper, very low CV.

DRIPPERS TECHNICAL DATA

FLOW RATE* (L/H)	MAXIMUM WORKING PRESSURE (BAR)	WATER PASSAGES DIMENSIONS WIDTH-DEPTH-LENGTH (MM)	FILTRATION AREA (MM²)	CONSTANT K	EXPONENT X
1.6	1.2	0.83 x 0.60 x 20	9.4	0.529	0.48
2.3	1.2	0.83 x 0.86 x 20	12.6	0.761	0.48

*Flow rate at 1.0 bar pressure **Arrow dripper at 1.6 l/h nominal flow rate, only available in the angle model.

ARROW DRIPPER MODEL

Catalog number **22000** - (any of below 6 digits)

MODEL	1 UNIT	20 UNITS/BAG	50 UNITS/BAG	100 UNITS/BAG	200 UNITS/BAG	1000 UNITS/BOX
Black 2.3 l/h angle	001300	001315	001317	001320	001325	001340
Gray 2.3 l/h angle	001420		001440	001450		
Gray 1.6 l/h angle	001250					
Black 2.3 l/h angle short	000900		000930	000920		000940
Gray 2.3 l/h angle short	001500			001550		
Black 2.3 l/h straight	001000		001020	001030		001040
Black 2.3 l/h straight + splitter	001100			001120		001140
Gray 2.3 l/h straight + splitter	001160		001170	001180		
Black 2.3 l/h straight + plug	001200	001210	001220	001230	001235	001240

Missing catalog numbers available upon request

PACKAGE DATA

MODEL	QUANTITY P/BOX UNITS	BOX DIMENSIONS (CM X CM X CM)	BOX WEIGHT (KG)
Black 2.3 l/h angle	1250	57 x 28 x 27	4.0
Gray 2.3 l/h angle	1250	57 x 28 x 27	4.0
Gray 1.6 l/h angle	1250	57 x 28 x 27	4.0
Black 2.3 l/h angle short	3000	57 x 28 x 27	5.7
Gray 2.3 l/h angle short	3000	57 x 28 x 27	5.7
Black 2.3 l/h straight	4000	57 x 28 x 27	9.8
Black 2.3 l/h straight + splitter	4000	57 x 28 x 27	10.4
Gray 2.3 l/h straight + splitter	4000	57 x 28 x 27	10.4
Black 2.3 l/h straight + plug	8500	57 x 28 x 27	5.3

END LINE PRODUCT



STRAIGHT W/SPLITTER
ARROW DRIPPER



STRAIGHT ARROW
DRIPPER



STRAIGHT W/PLUG
ARROW DRIPPER



ANGLED SHORT
ARROW DRIPPER



ANGLED LONG
ARROW DRIPPER



CAPINET™



APPLICATIONS

- Greenhouses, nurseries and garden pots.

FEATURES AND BENEFITS

- Dripper can be positioned exactly where required.
- Turbulent flow for highest reliability, efficiency and uniformity.
- Great flexibility by using 2.5*3.6 mm microtube to the exact location required.
- Special design stake enables stabilization of the CapiNet™ end on pots, beds and open fields.
Can hold the CapiNet™ straight up or at 45 degrees angle.
- No need for connectors , to connect to the distribution line.

SPECIFICATIONS

- Maximum working pressure: 2.0 bar.
- “Turbulent” labyrinth with large water passages.
- Recommended filtration: 130 micron / 120 mesh.
Filtration method is to be selected based on the kind and concentration of the dirt particles existing in the water. Wherever sand exceeding 2 ppm exists in the water, a Hydrocyclone is to be installed before the main filter. When sand/ silt/ clay solids exceed 100 ppm, pre treatment will be applied according to Netafim™ expert team’s instructions.
- To be “inserted” in heavy duty wall pipes (1.00, 1.20 mm).
- Injected dripper, very low CV.

DRIPPERS TECHNICAL DATA

FLOW RATE* (L/H)	MAXIMUM WORKING PRESSURE (BAR)	WATER PASSAGES DIMENSIONS WIDTH-DEPTH-LENGTH (MM)	CONSTANT K	EXPONENT X
1.95	2.0	0.76 x 0.70 x 21	0.630	0.49
2.75	2.0	0.76 x 0.70 x 11	0.890	0.49

*Flow rate at 1.0 bar pressure

CAPINET™

Catalog number **18700** - (any of below 6 digits)**

MODEL	20 CM LENGTH	40 CM LENGTH	60 CM LENGTH	80 CM LENGTH	100 CM LENGTH
1.95 l/h black	001600	001800	002000	002200	002500
1.95 l/h gray		003300	003500	003600	
2.75 l/h black		013000	013200	013400	

Missing catalog numbers available upon request

**Catalog number define a box with 3000 units

PACKAGE DATA

QUANTITY P/BOX UNITS	BOX DIMENSIONS (CM X CM X CM)	BOX WEIGHT (KG)
3000	57 x 28 x 27	5.5



SPIDERS

PRE-ASSEMBLED COMPONENTS

APPLICATIONS

- Greenhouses and nurseries irrigation.
- Ornamental plants.

BENEFITS

- All-in-one stand assembly reduce labor time and cost.
- Innovative assembly technologies improve assembly efficiency and reduce costs.
- Reliability, the products are installed under strict supervision of experts.
- All Spiders components were designed and produced under the same quality standards identifying all the Netafim™ products.
- Environmentally friendly, the Spiders tubes are made of softened PE not emitting the chemical agents normally used for softening similar tubes made of other raw materials.

SPECIFICATIONS

- Recommended working pressure must match the pressures specified for all Spiders components.
- Wherever there is more than one irrigation point it is recommended to use the Spiders with Arrow drippers as an end product in order unify the flow of each of the points.
- Wherever the Spiders serves a single irrigation point, the Netafim™ spike can be used.
- It is highly recommended not to design flows below 0.5 l/h per each irrigation point, namely, if a 2 l/h “mother” dripper is used, no more than 4 irrigation points should be designed. If 1.2 l/h “mother” dripper is used, no more than 2 irrigation points should be designed. This applies to all other flow models.
- The other side of the sheet details descriptions and assembly method of the Spiders different models.

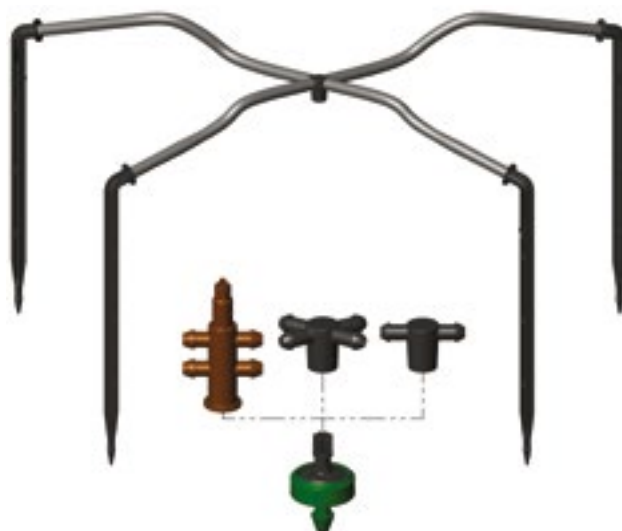

PRODUCT ASSEMBLY (SPIDERS)

Components available for your choice of assemblage

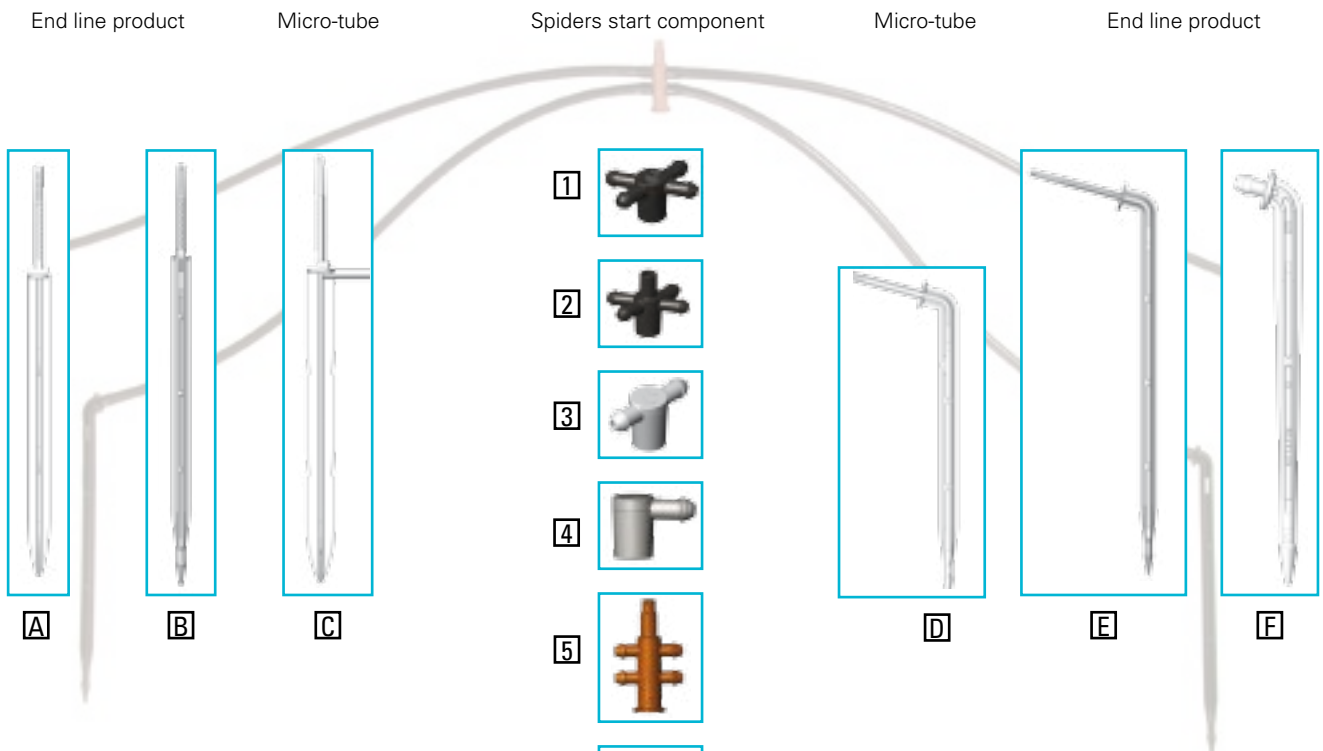

START PRODUCT

- 1 Flat manifold x 4 outlets
- 2 Flat manifold x 4 outlets w/nipple
- 3 Flat manifold x 2 outlets
- 4 Flat manifold elbow, one outlet
- 5 Upright manifold x 4 outlets
- 6 Upright manifold x 8 outlets
- 7 "T" 5 mm connector
- 8 Adapter to integral dripper
- 9 PCJ or any other on-line dripper
- 10 W/o start product

END LINE PRODUCT

- A Straight arrow dripper
- B Straight w/splitter arrow dripper
- C Straight w/plug arrow dripper
- D Angled short arrow dripper
- E Angled long arrow dripper
- F Spike

MICRO-TUBE

SSPE micro-tube 3*5 mm, 80 cm lenght, black
 SSPE micro-tube 3*5 mm, 40 cm lenght, gray
 SSPE micro-tube 3*5 mm , 60 cm lenght, gray
 SSPE micro-tube 3*5 mm, 80 cm lenght, gray
 SPE micro-tube 3*5 mm, 40 cm lenght, black
 SPE micro-tube 3*5 mm, 60 cm lenght, black
 SPE micro-tube 3*5 mm, 80 cm lenght, black

*please, add any required lenght by writing

SPE = Soft Polyethylene
 SSPE = Super Soft Polyethylene

The draws are non-uniformly scaled. They are for illustration purposes only.

EXAMPLES OF POPULAR ASSEMBLIES

FLAT MANIFOLD X 4 OUTLETS

CATALOG NUMBER	"SPIDER" START COMPONENT	MICRO TUBE MATERIAL	MICRO TUBE SIZE (MM X MM)	MICRO TUBE LENGTH (M)	END LINE COMPONENT
40200-001900	Flat manifold x 4 outlets	SPE	3.2*5	0.60	4 x straight arrow dripper w/splitter 2.3 l/h
40200-001950	Flat manifold x 4 outlets	SPE	3.2*5	0.70	4 x straight arrow dripper w/splitter 2.3 l/h
40200-002000	Flat manifold x 4 outlets	SPE	3.2*5	0.80	4 x straight arrow dripper w/splitter 2.3 l/h
40200-005980	Flat manifold x 4 outlets	SPE	3.2*5	0.25	4 x angled long arrow dripper 2.3 l/h
40200-005982	Flat manifold x 4 outlets	SPE	3.2*5	0.35	4 x angled long arrow dripper 2.3 l/h
40200-005989	Flat manifold x 4 outlets	SPE	3.2*5	0.30	4 x angled long arrow dripper 2.3 l/h
40200-005990	Flat manifold x 4 outlets	SPE	3.2*5	0.40	4 x angled long arrow dripper 2.3 l/h
40200-005995	Flat manifold x 4 outlets	SPE	3.2*5	0.50	4 x angled long arrow dripper 2.3 l/h
40200-006000	Flat manifold x 4 outlets	SPE	3.2*5	0.60	4 x angled long arrow dripper 2.3 l/h
40200-006040	Flat manifold x 4 outlets	SPE	3.2*5	0.60	4 x angled long arrow dripper 1.6 l/h(gray)
40200-006200	Flat manifold x 4 outlets	SPE	3.2*5	0.70	4 x angled long arrow dripper 2.3 l/h
40200-006300	Flat manifold x 4 outlets	SPE	3.2*5	0.75	4 x angled long arrow dripper 2.3 l/h
40200-006400	Flat manifold x 4 outlets	SPE	3.2*5	0.8	4 x angled long arrow dripper 2.3 l/h
40200-006445	Flat manifold x 4 outlets	SPE	3.2*5	1.00	4 x angled long arrow dripper 2.3 l/h
40200-006500	Flat manifold x 4 outlets	SPE	3.2*5	1.20	4 x angled long arrow dripper 2.3 l/h
40200-008850	Flat manifold x 4 outlets	SPE	3.2*5	0.20	4 x angled short arrow dripper 2.3 l/h
40200-008870	Flat manifold x 4 outlets	SPE	3.2*5	0.25	4 x angled short arrow dripper 2.3 l/h
40200-008900	Flat manifold x 4 outlets	SPE	3.2*5	0.30	4 x angled short arrow dripper 2.3 l/h
40200-009000	Flat manifold x 4 outlets	SPE	3.2*5	0.40	4 x angled short arrow dripper 2.3 l/h
40200-009020	Flat manifold x 4 outlets	SPE	3.2*5	0.60	4 x angled short arrow dripper 2.3 l/h
40200-009030	Flat manifold x 4 outlets	SPE	3.2*5	0.70	4 x angled short arrow dripper 2.3 l/h
40200-012150	Flat manifold x 4 outlets	SSPE (gray)	3.2*5	0.46	4 x Angled short arrow dripper 2.3 l/h
40200-012200	Flat manifold x 4 outlets	SSPE (gray)	3.2*5	0.76	4 x Angled long arrow dripper 2.3 l/h
40200-042520	Flat manifold x 4 outlets (gray)	SPE (gray)	3.2*5	0.60	4 x angled long arrow dripper 1.6 l/h(gray)
40200-042540	Flat manifold x 4 outlets (gray)	SPE (gray)	3.2*5	0.80	4 x angled long arrow dripper 1.6 l/h(gray)
40200-043100	Flat manifold x 4 outlets (gray)	SPE (gray)	3.2*5	0.60	4 x angled long arrow dripper 2.3 l/h(gray)
40200-043110	Flat manifold x 4 outlets (gray)	SPE (gray)	3.2*5	0.80	4 x angled long arrow dripper 2.3 l/h(gray)
40200-043300	Flat manifold x 4 outlets (gray)	SPE (gray)	3.2*5	0.40	4 x angled short arrow dripper 2.3 l/h(gray)



FLAT MANIFOLD X 2 OUTLETS

CATALOG NUMBER	"SPIDER" START COMPONENT	MICRO TUBE MATERIAL	MICRO TUBE SIZE (MM X MM)	MICRO TUBE LENGTH (M)	END LINE COMPONENT
40200-006560	Flat manifold x 2 outlets	SPE	3.2*5	0.30	2 x angled long arrow dripper 2.3 l/h
40200-006570	Flat manifold x 2 outlets	SPE	3.2*5	0.40	2 x angled long arrow dripper 2.3 l/h
40200-006580	Flat manifold x 2 outlets	SPE	3.2*5	0.50	2 x angled long arrow dripper 2.3 l/h
40200-006600	Flat manifold x 2 outlets	SPE	3.2*5	0.60	2 x angled long arrow dripper 2.3 l/h
40200-006602	Flat manifold x 2 outlets	SPE	3.2*5	0.60	2 x angled long arrow dripper 1.6 l/h (gray)
40200-006800	Flat manifold x 2 outlets	SPE	3.2*5	0.70	2 x angled long arrow dripper 2.3 l/h
40200-007000	Flat manifold x 2 outlets	SPE	3.2*5	0.8	2 x angled long arrow dripper 2.3 l/h
40200-007030	Flat manifold x 2 outlets	SPE	3.2*5	1.00	2 x angled long arrow dripper 2.3 l/h
40200-008470	Flat manifold x 2 outlets	SPE	3.2*5	0.50	2 x angled short arrow dripper 2.3 l/h
40200-008490	Flat manifold x 2 outlets	SPE	3.2*5	0.90	2 x angled short arrow dripper 2.3 l/h
40200-042420	Flat manifold x 2 outlets (gray)	SSPE (gray)	3.2*5	0.60	2 x angled long arrow dripper 1.6 l/h (gray)
40200-043000	Flat manifold x 2 outlets (gray)	SPE (gray)	3.2*5	0.60	2 x angled long arrow dripper 2.3 l/h (gray)
40200-043020	Flat manifold x 2 outlets (gray)	SPE (gray)	3.2*5	0.80	2 x angled long arrow dripper 2.3 l/h (gray)



UPRIGHT MANIFOLD X 4 OUTLETS

CATALOG NUMBER	"SPIDER" START COMPONENT	MICRO TUBE MATERIAL	MICRO TUBE SIZE (MM X MM)	MICRO TUBE LENGTH (M)	END LINE COMPONENT
40200-001900	Upright manifold x 4 outlets	SPE	3.2*5	0.60	4 x straight arrow dripper w/splitter 2.3 l/h
40200-001920	Upright manifold x 4 outlets	SPE	3.2*5	0.65	4 x straight arrow dripper w/splitter 2.3 l/h
40200-005982	Upright manifold x 4 outlets	SPE	3.2*5	0.35	4 x angled long arrow dripper 2.3 l/h
40200-005990	Upright manifold x 4 outlets	SPE	3.2*5	0.40	4 x angled long arrow dripper 2.3 l/h
40200-005995	Upright manifold x 4 outlets	SPE	3.2*5	0.50	4 x angled long arrow dripper 2.3 l/h
40200-006300	Upright manifold x 4 outlets	SPE	3.2*5	0.75	4 x angled long arrow dripper 2.3 l/h



PC & PCJ DRIPPERS

CATALOG NUMBER	"SPIDER" START COMPONENT	MICRO TUBE MATERIAL	MICRO TUBE SIZE (MM X MM)	MICRO TUBE LENGTH (M)	END LINE COMPONENT
40200-000965	PC HCNL 3 l/h , nipple + adaptor to fit 3*5 tube	SPE	3.2*5	0.80	Spike
40200-043200	PC LCNL 2 l/h nipple outlet + elbow adapter	SSPE (gray)	3.2*5	0.60	Spike (gray)
40200-005182	PC LCNL 2 l/h , nipple + adaptor to fit 3*5 tube	SPE	3.2*5	0.30	Spike
40200-005183	PC LCNL 2 l/h , nipple + brown adaptor to fit 3*5 tube	SPE	3.2*5	0.30	Spike
40200-005187	PC LCNL 2 l/h , nipple + brown adaptor to fit 3*5 tube	SPE	3.2*5	0.80	Spike
40200-004650	PCJ LCNL 2 l/h , 3 mm.barbed outlet	SPE	3.2*5	0.65	Plastic weight
40200-004700	PCJ LCNL 2 l/h , 3 mm.barbed outlet	SPE	3.2*5	0.30	Spike
40200-004750	PCJ LCNL 2 l/h , 3 mm.barbed outlet	SPE	3.2*5	0.40	Spike
40200-004755	PCJ LCNL 2 l/h , 3 mm.barbed outlet	SPE	3.2*5	0.60	-
40200-004757	PCJ LCNL 2 l/h , 3 mm.barbed outlet	SPE	3.2*5	0.80	-
40200-004758	PCJ LCNL 2 l/h , 3 mm.barbed outlet	SPE (gray)	3.2*5	0.80	-
40200-004800	PCJ LCNL 2 l/h , 3 mm.barbed outlet	SPE	3.2*5	0.45	Spike
40200-004900	PCJ LCNL 2 l/h , 3 mm.barbed outlet	SPE	3.2*5	0.50	Spike
40200-005000	PCJ LCNL 2 l/h , 3 mm.barbed outlet	SPE	3.2*5	0.60	Spike
40200-005100	PCJ LCNL 2 l/h , 3 mm.barbed outlet	SPE	3.2*5	0.70	Spike
40200-005200	PCJ LCNL 2 l/h , 3 mm.barbed outlet	SPE	3.2*5	0.80	Spike
40200-005220	PCJ LCNL 2 l/h , 3 mm.barbed outlet	SPE	3.2*5	1.00	Spike
40200-013000	PCJ LCNL 2 l/h , 3 mm.barbed outlet	SPE	3.2*5	0.76	Spike
40200-013010	PCJ LCNL 2 l/h , 3 mm.barbed outlet	SPE (gray)	3.2*5	0.76	Spike
40200-013015	PCJ LCNL 2 l/h , 3 mm.barbed outlet	SSPE (gray)	3.2*5	0.90	Spike
40200-013016	PCJ LCNL 2 l/h , 3 mm.barbed outlet	SSPE	3.2*5	0.90	Spike
40200-045000	PCJ LCNL 2 l/h , 3 mm.barbed outlet	SPE (gray)	3.2*5	0.60	Spike (gray)
40200-005265	PCJ LCNL 2 l/h nipple outlet + Flat manifold x 2 outlets	SPE	3.2*5	0.70	Spike
40200-005390	PCJ LCNL 4 l/h , 3 mm.barbed outlet	SPE	3.2*5	0.40	Spike
40200-005400	PCJ LCNL 4 l/h , 3 mm.barbed outlet	SPE	3.2*5	0.45	Spike
40200-005500	PCJ LCNL 4 l/h , 3 mm.barbed outlet	SPE	3.2*5	0.50	Spike
40200-005600	PCJ LCNL 4 l/h , 3 mm.barbed outlet	SPE	3.2*5	0.60	Spike
40200-005700	PCJ LCNL 4 l/h , 3 mm.barbed outlet	SPE	3.2*5	0.70	Spike



PC & PCJ DRIPPERS

CATALOG NUMBER	"SPIDER" START COMPONENT	MICRO TUBE MATERIAL	MICRO TUBE SIZE (MM X MM)	MICRO TUBE LENGTH (M)	END LINE COMPONENT
40200-005800	PCJ LCNL 4 l/h , 3 mm.barbed outlet	SPE	3.2*5	0.80	Spike
40200-013012	PCJ LCNL 4 l/h , 3 mm.barbed outlet	SSPE	3.2*5	0.60	Spike
40200-005850	PCJ LCNL 8 l/h , 3 mm.barbed outlet	SPE	3.2*5	0.60	Spike
40200-004760	PCJ LCNL 3 l/h, 3 mm. barbed outlet	SPE	3.2*5	0.50	-
40200-005275	PCJ LCNL 3 l/h, 3 mm. barbed outlet	SPE	3.2*5	0.40	Spike
40200-005275	PCJ LCNL 3 l/h, 3 mm. barbed outlet	SPE	3.2*5	0.40	Spike
40200-005280	PCJ LCNL 3 l/h, 3 mm. barbed outlet	SPE	3.2*5	0.45	Spike
40200-005285	PCJ LCNL 3 l/h, 3 mm. barbed outlet	SPE	3.2*5	0.50	Spike
40200-005287	PCJ LCNL 3 l/h, 3 mm. barbed outlet	SPE	3.2*5	0.55	Spike
40200-005290	PCJ LCNL 3 l/h, 3 mm. barbed outlet	SPE	3.2*5	0.60	Spike
40200-005300	PCJ LCNL 3 l/h, 3 mm. barbed outlet	SPE	3.2*5	0.70	Spike
40200-005320	PCJ LCNL 3 l/h, 3 mm. barbed outlet	SPE	3.2*5	0.80	Spike
40200-005341	PCJ LCNL 3 l/h, 3 mm. barbed outlet	SPE	3.2*5	0.85	Spike
40200-013020	PCJ LCNL 3 l/h, 3 mm. barbed outlet	SPE (gray)	3.2*5	0.76	Spike
40200-045500	PCJ LCNL 3 l/h, 3 mm. barbed outlet	SPE (gray)	3.2*5	0.70	Spike (gray)





ASSEMBLED DRIPPERLINES

PRE-ASSEMBLED COMPONENTS

APPLICATIONS

- Greenhouses and nurseries irrigation.
- Ornamental plants.

BENEFITS

- All-in-one stand assembly reduce labor time and cost.
- Innovative assembly technologies improve assembly efficiency and reduce costs.
- Reliability, the products are installed under strict supervision of experts.
- All Spiders' components were designed and produced under the same quality standards identifying all the Netafim™ products.
- Environmentally friendly, the Spider's tubes are made of softened PE not emitting the chemical agents normally used for softening similar tubes made of other raw materials.

SPECIFICATIONS

- Recommended working pressure must match that of the products assembled on the sub main pipes and consider pipe diameter and head losses.
- The other side of the sheet details definitions and assembly method of the different products.

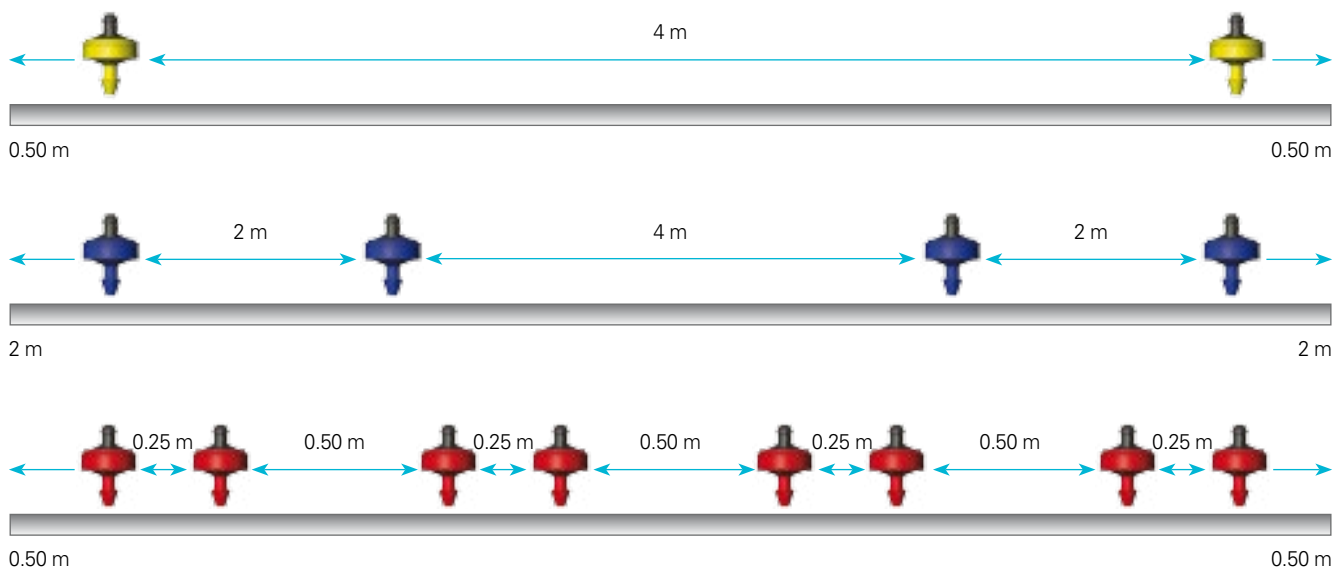

FLOWCHART TO DETERMINE THE DESIRED PRODUCT DEFINITION

DA	PIPE DESCRIPTION	EMITTER	CLUSTER	DISTANCE BETWEEN CLUSTERS	TOTAL COIL LENGTH	INITIAL AND END LENGHT
	12/2.5	PC2.0	1	0.20M	50M	ID0.50M
	12/4	PC4.0	2*0.15M	0.30M	100M	ID0.75M
	16/2.5	PC8.5	2*0.20M	0.40M	150M	ID1.00M
	16/4	PCLCNL2.0	2*0.30M	0.50M	200M	ID1.25M
	20/2.5	PCLCNL4.0	2*0.40M	1.00M	400M	ID1.50M
	20/4	PCLCNL8.5	2*0.50M	1.20M		ID1.75M
	25/2.5	PCJ0.5		1.50M		ID2.00M
	25/4	PCJ1.2				ID2.25M
	12/2.5G	PCJ2.0				IDX.XXM
	12/4G	PCJ3.0				
	16/2.5G	PCJ4.0				
	16/4G	PCJ8.0				
	20/2.5G	PCJ12.0				
	20/4G	PCJLCNL0.5				
	25/2.5G	PCJLCNL1.2				
	25/4G	PCJLCNL2.0				
		PCJLCNL3.0				
		PCJLCNL4.0				
		PCJLCNL8.0				
		PCJLCNL12.0				
		ZZZZZ				

Pipe description:

Outside diameter/class, the letter G denote a light gray color, if these do not appear it will be a black pipe.

Emitter:

Can be a single dripper or an assembled "Spider", in which case it will be required to add the last 6 digits of the "Spider" Netafim™ catalog number.

Cluster:

One single dripper or "Spider" on a group of two emitters with specific distance between them.

Distance between clusters:

The required distance between the centers of one cluster to the center of the next cluster.

Total coil length:

The required length per each coil (including initial and end length).

Initial and end length:

The required distance between the start of the pipe to the first emitter punched on it, must be identical to the distance between the last emitter punched and the end of that pipe.



NETAFIM™ BLANK DRIPPERLINES

DRIPPERLESS DRIPPERLINES (WITHOUT DRIPPERS INSIDE)

APPLICATIONS

For use in agricultural drip, micro-sprinkler, landscape and mining irrigation systems.

FEATURES AND BENEFITS

- All pipes are manufactured with UV and oxidation protection making them durable to solar radiation without significant damage for at least 50 years.
- Microorganisms or fungi do not attack PE pipes, either internally or externally.
- PE pipes are resistant to saline water, acid or alkaline solutions (excluding highly concentrated solutions) and to most substances employed in agricultural applications.
- Available in standard coil lengths.
- Made with the finest available low/medium density polyethylene resin, especially formulated to resist cracking and kinking, and to ensure long-term reliability.
- Precision manufacturing to ensure the uniformity of internal diameter and wall thickness.

SPECIFICATIONS

- PE pipes (100% PE, totally recyclable).
- Inside diameters and wall thicknesses according to the Netafim™ dripperline product basket can be used as risers, connectors or distribution pipes.
- Can be used as distribution pipes for micro-sprinkler irrigation systems.

BLANK DRIPPERLINES (COLORED BLACK)

Catalog number **19950** - (any of below 6 digits)

MODEL	100 (M)	200 (M)	300 (M)	400 (M)
12010	000830	000945		000840
16010	001400	001410	001415	001420
16012	001000		001100	001200
17012	004600	004700	004800	004900
20010	008500	008600	008700	N/A
20012	008150	008300	008400	N/A
23009				009500
23010			009520	N/A

Missing catalog numbers available upon request

BLANK DRIPPERLINES (COLORED BROWN)

Catalog number **19950** - (any of below 6 digits)

MODEL	25 (M)	50 (M)	100 (M)	200 (M)	500 (M)
16010	003200	003300	003400	003500	003600
16012	002700	002720	002740		
17012		006700	006800	006900	

Missing catalog numbers available upon request

BLANK DRIPPERLINES (COLORED DARK BROWN)

Catalog number **19950** - (any of below 6 digits)

MODEL	25 (M)	50 (M)	100 (M)
12010	000910	000920	000930
16012	003100	003120	

Missing catalog numbers available upon request

BLANK DRIPPERLINES (COLORED VIOLET)

Catalog number **19950** - (any of below 6 digits)

MODEL	200 (M)	300 (M)	400 (M)
16010	003970		
17012			007500
20012		009300	

Missing catalog numbers available upon request

BLANK DRIPPERLINES (COLORED LIGHT GRAY)

Catalog number **19950** - (any of below 6 digits)

MODEL	300 (M)	400 (M)	500 (M)
16010			003700
16012		001260	N/A
17012		004400	N/A
20012	009310	N/A	N/A

Missing catalog numbers available upon request



UNITECHLINE™ AS

PRESSURE-COMPENSATING, CONTINUOUSLY SELF-CLEANING,
ANTI-SIPHON MECHANISM DRIPPER



APPLICATIONS

- Sub-surface and on-surface installation.
- Slopes.
- High wind areas.
- Areas subject to vandalism.
- Planting areas.
- Curved, narrow and unshaped planting areas.
- Turf, shrubs, trees and flowers.
- Rooftop gardens.
- Green walls.
- Sports turf, tennis courts and golf courses.
- High traffic/high liability areas.
- Raised planters.

FEATURES AND BENEFITS

PRESSURE COMPENSATING

- Precise and equal amounts of water are delivered over a broad pressure range.
- 100 % uniformity of water and nutrients distribution along the laterals.

CONTINUOUS SELF-FLUSHING DRIPPER DESIGN

- Flushes debris as it is detected, throughout operation, not just at the beginning or end of a cycle, ensuring uninterrupted dripper operation.
- Anti-Siphon mechanism prevents contaminants from being drawn into the dripper.

UNIQUE DRIPPER DESIGN WITH

- Physical root barrier: better protection against root intrusion without reliance on chemicals.
- Largest filter in each dripper.
- Widest water passages within the dripper.
- Unique TurboNet™ flow path.

DRIPPER POSITION WITHIN THE DRIPPERLINE

- The water is drawn in to the dripper from the stream center, preventing the entrance of sediments in to the drippers.

FLEXIBLE TUBING

- Adapts to any planting area shape.

UV RESISTANT

- Withstands heat and direct sun - for on-surface installations.

SPECIFICATIONS

- Broadest choice of dripper flow rates: 1.0, 1.6, 2.3, 3.5 l/h.
- Dripper spacing's: 0.3, 0.4, 0.5, 1.00 m (other dripper spacing available upon request).
- Pressure-compensating range: 0.5-4.0 bar.
- Anti-siphon mechanism.
- Recommended filtration: 130 micron / 120 mesh.
- Coil length: 50, 100, 200, 400 m.

DRIPPERS TECHNICAL DATA

FLOW RATE* (L/H)	WORKING PRESSURE RANGE (BAR)	WATER PASSAGES DIMENSIONS WIDTH-DEPTH-LENGTH (MM)	FILTRATION AREA (MM ²)	CONSTANT K	EXPONENT * X	RECOMMENDED FILTRATION (MICRON)/(MESH)
1.0	0.5 – 4.0	0.83 x 0.74 x 40	130	1.0	0	130/120
1.6	0.5 – 4.0	1.07 x 0.79 x 40	130	1.6	0	200/80
2.3	0.5 – 4.0	1.26 x 0.95 x 40	130	2.3	0	200/80
3.5	0.5 – 4.0	1.59 x 1.10 x 40	150	3.5	0	200/80

*Within working pressure range

UNITECHLINE™ AS 16010

Catalog number: 14720 - (any of bellow 6 digits)

FLOW RATE (L/H)	DISTANCE BETWEEN DRIPPERS (M)																
	0.30	0.40	0.50	1.00	0.30	0.40	0.50	1.00	0.30	0.40	0.50	1.00	0.30	0.40	0.50	1.00	
1.0																	
1.6			002380		002100									002240	002340		
2.3																	
3.5																	004720
Bundled coil length (meter)	50	50	50	50	100	100	100	100	200	200	200	200	400	400	400	400	

Missing catalog numbers available upon request

DRIPPERLINE TECHNICAL DATA

MODEL	INSIDE DIAMETER (MM)	WALL THICKNESS (MM)	OUTSIDE DIAMETER (MM)	MAX. WORKING PRESSURE (BAR)	KD
16010	14.20	1.20	16.60	4.0	1.3

DRIPPERLINE PACKAGE DATA

MODEL	COIL LENGTH (METER)	DISTANCE BETWEEN DRIPPERS (METER)	AVERAGE COIL WEIGHT (KG)	COILS IN A 40 FEET CONTAINER (UNITS)	TOTAL IN A 40 FEET CONTAINER (METERS)	COILS IN A 20 FEET CONTAINER (UNITS)	TOTAL IN A 20 FEET CONTAINER (METERS)
16010	50	0.20 to 1.00	2.4	1440	72000	720	36000
	100		4.6	960	96000	480	48000
	200		9.2	480	96000	240	48000
	400		23.0	352	140800	176	70400

UNITECHLINE™ AS 16012

Catalog number: 14710 - (any of bellow 6 digits)

FLOW RATE (L/H)	DISTANCE BETWEEN DRIPPERS (M)																
	0.30	0.40	0.50	1.00	0.30	0.40	0.50	1.00	0.30	0.40	0.50	1.00	0.30	0.40	0.50	1.00	
1.0																	
1.6	003000	003600	003900	005300	003100	003700	004000	005400		003720				003200	003800	004100	005500
2.3	006000	006600	006900	008300	006100	006700	007000	008400						006200	006800	007100	008500
3.5									009590								
Bundled coil length (meter)	50	50	50	50	100	100	100	100	200	200	200	200	400	400	400	400	

Missing catalog numbers available upon request

DRIPPERLINE TECHNICAL DATA

MODEL	INSIDE DIAMETER (MM)	WALL THICKNESS (MM)	OUTSIDE DIAMETER (MM)	MAX. WORKING PRESSURE (BAR)	KD
16012	14.20	1.20	16.60	4.0	1.3

DRIPPERLINE PACKAGE DATA

MODEL	COIL LENGTH (METER)	DISTANCE BETWEEN DRIPPERS (METER)	AVERAGE COIL WEIGHT (KG)	COILS IN A 40 FEET CONTAINER (UNITS)	TOTAL IN A 40 FEET CONTAINER (METERS)	COILS IN A 20 FEET CONTAINER (UNITS)	TOTAL IN A 20 FEET CONTAINER (METERS)
16012	50	0.20 to 1.00	2.9	1440	72000	720	36000
	100		5.9	960	96000	480	48000
	200		11.7	480	96000	240	48000
	400		23.5	352	140800	176	70400

UNITECHLINE™ AS 17012

Catalog number: 14800- (any of bellow 6 digits)

FLOW RATE (L/H)	DISTANCE BETWEEN DRIPPERS (M)																
	0.30	0.40	0.50	1.00	0.30	0.40	0.50	1.00	0.30	0.40	0.50	1.00	0.30	0.40	0.50	1.00	
1.0																	
1.6	001850	002150	002300	003600	001900			003650						001950	002250	002400	003700
2.3	003850	003980	004050	004950	003900		004100	005000						003950	004000	004200	005100
3.5					006500												
Bundled coil length (meter)	50	50	50	50	100	100	100	100	200	200	200	200	400	400	400	400	

Missing catalog numbers available upon request

DRIPPERLINE TECHNICAL DATA

MODEL	INSIDE DIAMETER (MM)	WALL THICKNESS (MM)	OUTSIDE DIAMETER (MM)	MAX. WORKING PRESSURE (BAR)	KD
17012	14.60	1.20	17.00	4.0	1.1

DRIPPERLINE PACKAGE DATA

MODEL	COIL LENGTH (METER)	DISTANCE BETWEEN DRIPPERS (METER)	AVERAGE COIL WEIGHT (KG)	COILS IN A 40 FEET CONTAINER (UNITS)	TOTAL IN A 40 FEET CONTAINER (METERS)	COILS IN A 20 FEET CONTAINER (UNITS)	TOTAL IN A 20 FEET CONTAINER (METERS)
17012	50	0.20 to 1.00	3.2	1440	72000	720	36000
	100		6.5	960	96000	480	48000
	200		12.5	480	96000	240	48000
	400		24.9	352	140800	176	70400





TECHLINE™ CV

PRESSURE-COMPENSATING, CONTINUOUSLY SELF-CLEANING DRIPPER
CHECK VALVE ANTI-DRAIN (CV)



APPLICATIONS

- Sub-surface and on-surface installation.
- Slopes.
- High wind areas.
- Areas subject to vandalism.
- Planting areas.
- Curved, narrow and unshaped planting areas.
- Turf, shrubs, trees and flowers.
- Rooftop gardens.
- Green walls.
- Sports turf, tennis courts and golf courses.
- High traffic/high liability areas.
- Raised planters.

FEATURES AND BENEFITS

PRESSURE COMPENSATING

- Precise and equal amounts of water are delivered over a broad pressure range.
- 100 % uniformity of water and nutrients distribution along the laterals.

CONTINUOUS SELF-FLUSHING DRIPPER DESIGN

- Flushes debris as it is detected, throughout operation, not just at the beginning or end of a cycle, ensuring uninterrupted dripper operation.

0.14 BAR CHECK VALVE IN EACH DRIPPER

- All drippers turn on and off at the same time, maximizing balance of application. System holds back up to 1.4 m of water (elevation change). No low emitter drainage, great on slopes. Delivers more precise watering.

ANTI-SIPHON MECHANISM

- Anti-Siphon mechanism prevents contaminants from being drawn into the dripper.

UNIQUE DRIPPER DESIGN WITH

- Physical root barrier: better protection against root intrusion without reliance on chemicals.
- Largest filter in each dripper.
- Widest water passages within the dripper.
- Unique TurboNet™ flow path.

DRIPPER POSITION WITHIN THE DRIPPERLINE

- The water is drawn in to the dripper from the stream center, preventing the entrance of sediments in to the drippers.

FLEXIBLE TUBING

- Adapts to any planting area shape.

UV RESISTANT

- Withstands heat and direct sun - for on-surface installations.

SPECIFICATIONS

- Broadest choice of dripper flow rates: 1.0, 1.6, 2.3, 3.5 l/h.
- Dripper spacing's: 0.3, 0.4, 0.5, 1.00 m (other dripper spacing available upon request).
- Pressure-compensating range: 1.0-4.0 bar.
- Anti-drain mechanism, shut-off pressure 0.14 bar
- Anti-siphon mechanism.
- Recommended filtration: 130 micro / 120 mesh.
- Coil length: 50, 100, 200, 400 m.

DRIPPERS TECHNICAL DATA

FLOW RATE* (L/H)	WORKING PRESSURE RANGE (BAR)	WATER PASSAGES DIMENSIONS WIDTH-DEPTH-LENGTH (MM)	FILTRATION AREA (MM ²)	CONSTANT K	EXPONENT * X	RECOMMENDED FILTRATION (MICRON)/(MESH)
1.0	1.0 – 4.0	0.83 x 0.74 x 40	130	1.0	0	130/120
1.6	1.0 – 4.0	1.07 x 0.79 x 40	130	1.6	0	200/80
2.3	1.0 – 4.0	1.26 x 0.95 x 40	130	2.3	0	200/80
3.5	1.0 – 4.0	1.59 x 1.10 x 40	150	3.5	0	200/80

*Within working pressure range

TECHLINE™ CV 16012

Catalog number: **14700** - (any of bellow 6 digits)

FLOW RATE (L/H)	DISTANCE BETWEEN DRIPPERS (M)																
	0.30	0.40	0.50	1.00	0.30	0.40	0.50	1.00	0.30	0.40	0.50	1.00	0.30	0.40	0.50	1.00	
1.0						002750	002760										
1.6					002800				002850								
2.3			006200				006250								006300		
3.5																	
Bundled coil length (meter)	50	50	50	50	100	100	100	100	200	200	200	200	400	400	400	400	

Missing catalog numbers available upon request

DRIPPERLINE TECHNICAL DATA

MODEL	INSIDE DIAMETER (MM)	WALL THICKNESS (MM)	OUTSIDE DIAMETER (MM)	MAX. WORKING PRESSURE (BAR)	KD
16012	14.20	1.20	16.60	4.0	1.3

DRIPPERLINES PACKAGE DATA

MODEL	COIL LENGTH (METER)	DISTANCE BETWEEN DRIPPERS (METER)	AVERAGE COIL WEIGHT (KG)	COILS IN A 40 FEET CONTAINER (UNITS)	TOTAL IN A 40 FEET CONTAINER (METERS)	COILS IN A 40 FEET CONTAINER (UNITS)	TOTAL IN A 40 FEET CONTAINER (METERS)
16012	50	0.20 to 1.00	2.9	1440	72000	720	36000
	100		5.9	960	96000	480	48000
	200		11.7	480	96000	240	48000
	400		23.5	352	140800	176	70400



BIOLINE™ AS

PRESSURE-COMPENSATING, CONTINUOUSLY
SELF-CLEANING, ANTI-SIPHON DRIPPER



APPLICATIONS

- For irrigation with non-potable water.
- Sub-surface installations.
- Commercial and residential applications.
- Turf/Lawn, shrubs, trees, flowerbeds.

FEATURES AND BENEFITS

PRESSURE COMPENSATING

- Precise and equal amounts of water are delivered over a broad pressure range.
- 100 % uniformity of water and nutrients distribution along the laterals.

CONTINUOUS SELF-FLUSHING DRIPPER DESIGN

- Flushes debris as it is detected, throughout operation, not just at the beginning or end of a cycle, ensuring uninterrupted dripper operation.

ANTI-SIPHON MECHANISM

- Anti-Siphon mechanism prevents contaminants from being drawn into the dripper.

UNIQUE DRIPPER DESIGN WITH

- Physical root barrier: better protection against root intrusion without reliance on chemicals.
- Largest filter in each dripper.
- Widest water passages within the dripper.
- Unique TurboNet™ flow path.

DRIPPER POSITION WITHIN THE DRIPPERLINE

- The water is drawn in to the dripper from the stream center, preventing the entrance of sediments in to the drippers.

FLEXIBLE TUBING

- Adapts to any planting area shape.

UV RESISTANT

- Withstands heat and direct sun - for on-surface installations.
- Colored dripperline for easy identification when is needed to warns of the use of non-potable water

SPECIFICATIONS

- Purple-colored dripperline warns of the use of non-potable water.
- Broadest choice of dripper flow rates: 1.0, 1.6, 2.3, 3.5 l/h.
- Dripper spacing's: 0.3, 0.4, 0.5, 1.00 m (other dripper spacing available upon request).
- Pressure-compensating range: 0.5-4.0 bar.
- Anti-siphon mechanism.
- Recommended filtration: 130 micron / 120 mesh.
- Coil length: 50, 100, 200, 400 m.

DRIPPERS TECHNICAL DATA

FLOW RATE* (L/H)	WORKING PRESSURE RANGE (BAR)	WATER PASSAGES DIMENSIONS WIDTH-DEPTH-LENGTH (MM)	FILTRATION AREA (MM ²)	CONSTANT K	EXPONENT *	RECOMMENDED FILTRATION (MICRON)/(MESH)
1.0	0.5 – 4.0	0.83 x 0.74 x 40	130	1.0	0	130/120
1.6	0.5 – 4.0	1.07 x 0.79 x 40	130	1.6	0	200/80
2.3	0.5 – 4.0	1.26 x 0.95 x 40	130	2.3	0	200/80
3.5	0.5 – 4.0	1.59 x 1.10 x 40	150	3.5	0	200/80

*Within working pressure range

BIOLINE™ AS 16010

Catalog number: **13960** - (any of bellow 6 digits)

FLOW RATE (L/H)	DISTANCE BETWEEN DRIPPERS (M)															
	0.30	0.40	0.50	1.00	0.30	0.40	0.50	1.00	0.30	0.40	0.50	1.00	0.30	0.40	0.50	1.00
1.0											001500	002000				
1.6				003000			002560	003000	002350	002490	002570				002580	
2.3							003640				003645	004100				004200
3.5				005000					004300						004550	
Bundled coil length (meter)	50	50	50	50	100	100	100	100	200	200	200	200	400	400	400	400

Missing catalog numbers available upon request

DRIPPERLINES TECHNICAL DATA

MODEL	INSIDE DIAMETER (MM)	WALL THICKNESS (MM)	OUTSIDE DIAMETER (MM)	MAX. WORKING PRESSURE (BAR)	KD
16010	14.20	1.00	16.20	3.5	1.3

DRIPPERLINES PACKAGE DATA

MODEL	COIL LENGTH (METER)	DISTANCE BETWEEN DRIPPERS (METER)	AVERAGE COIL WEIGHT (KG)	COILS IN A 40 FEET CONTAINER (UNITS)	TOTAL IN A 40 FEET CONTAINER (METERS)	COILS IN A 40 FEET CONTAINER (UNITS)	TOTAL IN A 40 FEET CONTAINER (METERS)
16010	50	0.20 to 1.00	2.4	1440	72000	720	36000
	100		4.6	960	96000	480	48000
	200		9.2	480	96000	240	48000
	400		23.0	352	140800	176	70400

BIOLINET™ AS 16012

Catalog number: **13930** - (any of bellow 6 digits)

FLOW RATE (L/H)	DISTANCE BETWEEN DRIPPERS (M)															
	0.30	0.40	0.50	1.00	0.30	0.40	0.50	1.00	0.30	0.40	0.50	1.00	0.30	0.40	0.50	1.00
1.0					001300											
1.6					002450				002500				002525		002750	003550
2.3							004500								004550	
3.5									005000							
Bundled coil length (meter)	50	50	50	50	100	100	100	100	200	200	200	200	400	400	400	400

Missing catalog numbers available upon request

DRIPPERLINES TECHNICAL DATA

MODEL	INSIDE DIAMETER (MM)	WALL THICKNESS (MM)	OUTSIDE DIAMETER (MM)	MAX. WORKING PRESSURE (BAR)	KD
16012	14.20	1.20	16.60	4.0	1.3

DRIPPERLINES PACKAGE DATA

MODEL	COIL LENGTH (METER)	DISTANCE BETWEEN DRIPPERS (METER)	AVERAGE COIL WEIGHT (KG)	COILS IN A 40 FEET CONTAINER (UNITS)	TOTAL IN A 40 FEET CONTAINER (METERS)	COILS IN A 40 FEET CONTAINER (UNITS)	TOTAL IN A 40 FEET CONTAINER (METERS)
16012	50	0.20 to 1.00	2.9	1440	72000	720	36000
	100		5.9	960	96000	480	48000
	200		11.7	480	96000	240	48000
	400		23.5	352	140800	176	70400

BIOLINET™ AS 17012

Catalog number: **14090** - (any of bellow 6 digits)

FLOW RATE (L/H)	DISTANCE BETWEEN DRIPPERS (M)															
	0.30	0.40	0.50	1.00	0.30	0.40	0.50	1.00	0.30	0.40	0.50	1.00	0.30	0.40	0.50	1.00
1.0																
1.6													002900			
2.3													004400	004500		
3.5																
Bundled coil length (meter)	50	50	50	50	100	100	100	100	200	200	200	200	400	400	400	400

Missing catalog numbers available upon request

DRIPPERLINES TECHNICAL DATA

MODEL	INSIDE DIAMETER (MM)	WALL THICKNESS (MM)	OUTSIDE DIAMETER (MM)	MAX. WORKING PRESSURE (BAR)	KD
17012	14.60	1.20	17.00	4.0	1.1

DRIPPERLINES PACKAGE DATA

MODEL	COIL LENGTH (METER)	DISTANCE BETWEEN DRIPPERS (METER)	AVERAGE COIL WEIGHT (KG)	COILS IN A 40 FEET CONTAINER (UNITS)	TOTAL IN A 40 FEET CONTAINER (METERS)	COILS IN A 40 FEET CONTAINER (UNITS)	TOTAL IN A 40 FEET CONTAINER (METERS)
17012	50	0.20 to 1.00	3.2	1440	72000	720	36000
	100		6.5	960	96000	480	48000
	200		12.5	480	96000	240	48000
	400		24.9	352	140800	176	70400





TECHNET™

PRESSURE-COMPENSATING, CONTINUOUSLY SELF-CLEANING DRIPPER



APPLICATIONS

- On-surface installation.
- High wind areas.
- Planting areas.
- Curved, narrow and unshaped planting areas.
- Shrubs, trees, flowers.
- Rooftop gardens.
- High traffic/high liability areas.
- Raised planters.

FEATURES AND BENEFITS

PRESSURE COMPENSATING

- Precise and equal amounts of water are delivered over a broad pressure range.
- 100 % uniformity of water and nutrients distribution along the laterals.

CONTINUOUS SELF-FLUSHING DRIPPER DESIGN

- Flushes debris as it is detected, throughout operation, not just at the beginning or end of a cycle, ensuring uninterrupted dripper operation.

UNIQUE DRIPPER DESIGN WITH

- Physical root barrier: better protection against root intrusion without reliance on chemicals.
- Large filter in each dripper.
- Widest water passages within the dripper.
- Unique TurboNet™ flow path.

DRIPPER POSITION WITHIN THE DRIPPERLINE

- The water is drawn in to the dripper from the stream center, preventing the entrance of sediments in to the drippers.

FLEXIBLE TUBING

- Adapts to any planting area shape.

UV RESISTANT

- Withstands heat and direct sun - for on-surface installations.

SPECIFICATIONS

- Broadest choice of dripper flow rates: 1.0, 1.6, 2.0, 3.0 l/h.
- Dripper spacing's: 0.3, 0.4, 0.5, 1.00 m (other dripper spacing available upon request).
- Pressure-compensating range: 0.4-3.0 bar.
- Recommended filtration: 130 micron / 120 mesh.
- Coil length: 50, 100, 200, 400/500 m.

DRIPPERS TECHNICAL DATA

FLOW RATE* (L/H)	WORKING PRESSURE RANGE (BAR)	WATER PASSAGES DIMENSIONS WIDTH-DEPTH-LENGTH (MM)	FILTRATION AREA (MM ²)	CONSTANT K	EXPONENT * X
1.0	0.40 - 3.0	0.61 x 0.60 x 8	39	1.0	0
1.6	0.40 - 3.0	0.76 x 0.73 x 8	39	1.6	0
2.0	0.40 - 3.5	0.84 x 0.80 x 8	39	2.0	0
3.0	0.40 - 3.5	1.02 x 0.88 x 8	39	3.0	0

*Within working pressure range

TECHNET™ 16 120

Catalog number: **17710** - (any of bellow 6 digits)

FLOW RATE (L/H)	DISTANCE BETWEEN DRIPPERS (M)																
	0.30	0.40	0.50	1.00	0.30	0.40	0.50	1.00	0.30	0.40	0.50	1.00	0.30	0.40	0.50	1.00	
1.0																002200	
1.6	003150	003480	003650	004780	003200	003500	003700	004800									
2.0					006150		006500	006900					006170				
3.0									008100								
Bundled coil length (meter)	50	50	50	50	100	100	100	100	200	200	200	200	400	400	400	400	

Missing catalog numbers available upon request

DRIPPERLINE TECHNICAL DATA

MODEL	INSIDE DIAMETER (MM)	WALL THICKNESS (MM)	OUTSIDE DIAMETER (MM)	MAX. WORKING PRESSURE (BAR)	KD
16 120	14.20	1.20	16.60	4.0	0.72

DRIPPERLINES PACKAGE DATA

MODEL	COIL LENGTH (METER)	DISTANCE BETWEEN DRIPPERS (METER)	AVERAGE COIL WEIGHT (KG)	COILS IN A 40 FEET CONTAINER (UNITS)	TOTAL IN A 40 FEET CONTAINER (METERS)	COILS IN A 40 FEET CONTAINER (UNITS)	TOTAL IN A 40 FEET CONTAINER (METERS)
16 120	50	0.20 to 1.00	2.7	1440	72000	720	36000
	100		5.5	960	96000	480	48000
	200		11.0	480	96000	240	48000
	400		22.0	352	140800	176	70400

TECHNET™ 16 100

Catalog number: **17680** - (any of bellow 6 digits)

FLOW RATE (L/H)	DISTANCE BETWEEN DRIPPERS (M)																
	0.30	0.40	0.50	1.00	0.30	0.40	0.50	1.00	0.30	0.40	0.50	1.00	0.30	0.40	0.50	1.00	
1.0																005000	
1.6	006120		006580		006130	006350	006600	007300	006200	006410	006610	007310	006210	006450	006620	007340	
2.0					007400									007420	007450		007600
3.0																	
Bundled coil length (meter)	50	50	50	50	100	100	100	100	200	200	200	200	500	500	500	500	

Missing catalog numbers available upon request

DRIPPERLINE TECHNICAL DATA

MODEL	INSIDE DIAMETER (MM)	WALL THICKNESS (MM)	OUTSIDE DIAMETER (MM)	MAX. WORKING PRESSURE (BAR)	KD
16 100	14.20	1.00	16.20	3.5	0.72

DRIPPERLINES PACKAGE DATA

MODEL	COIL LENGTH (METER)	DISTANCE BETWEEN DRIPPERS (METER)	AVERAGE COIL WEIGHT (KG)	COILS IN A 40 FEET CONTAINER (UNITS)	TOTAL IN A 40 FEET CONTAINER (METERS)	COILS IN A 20 FEET CONTAINER (UNITS)	TOTAL IN A 20 FEET CONTAINER (METERS)
16 100	50	0.20 to 1.00	3.2	1440	72000	720	36000
	100		6.5	960	96000	480	48000
	200		12.5	480	96000	240	48000
	500		24.9	352	176000	176	88000





TECHNET™ AS

PRESSURE COMPENSATING, CONTINUOUSLY SELF-CLEANING,
ANTI-SIPHON DRIPPER



APPLICATIONS

- On-surface installation or covered with a layer of mulch.
- Sub-surface installation.
- High wind areas.
- Planting areas.
- Curved, narrow and unshaped planting areas.
- Shrubs, trees, flowers.
- Rooftop gardens.
- High traffic/high liability areas.
- Raised planters.

FEATURES AND BENEFITS

PRESSURE COMPENSATING

- Precise and equal amounts of water are delivered over a broad pressure range.
- 100% uniformity of water and nutrients distribution along the laterals.

CONTINUOUS SELF-FLUSHING DRIPPER DESIGN

- Flushes debris as it is detected, throughout operation, not just at the beginning or end of a cycle, ensuring uninterrupted dripper operation.

ANTI-SIPHON MECHANISM

- Anti-Siphon mechanism prevents contaminants from being drawn into the dripper.

UNIQUE DRIPPER DESIGN WITH

- Physical root barrier: better protection against root intrusion without reliance on chemicals.
- Large filter in each dripper.
- Widest water passages within the dripper.
- Unique TurboNet™ flow path.

DRIPPER POSITION WITHIN THE DRIPPERLINE

- The water is drawn in to the dripper from the stream center, preventing the entrance of sediments in to the drippers.

FLEXIBLE TUBING

- Adapts to any planting area shape.

UV RESISTANT

- Withstands heat and direct sun - for on-surface installations.

SPECIFICATIONS

- Broadest choice of dripper flow rates: 1.0, 1.6, 2.0, 3.0 l/h.
- Dripper spacing's: 0.3, 0.4, 0.5, 1.00 m (other dripper spacing available upon request).
- Pressure-compensating range: 0.4-3.0 bar.
- Anti-siphon mechanism.
- Recommended filtration: 130 micron / 120 mesh.
- Coil length: 50, 100, 200, 400/500 m.

DRIPPERS TECHNICAL DATA

FLOW RATE* (L/H)	WORKING PRESSURE RANGE (BAR)	WATER PASSAGES DIMENSIONS WIDTH-DEPTH-LENGTH (MM)	FILTRATION AREA (MM ²)	CONSTANT K	EXPONENT * X
1.0	0.40 - 3.0	0.61 x 0.60 x 8	42	1.0	0
1.6	0.40 - 3.0	0.76 x 0.73 x 8	42	1.6	0
2.0	0.40 - 3.5	0.84 x 0.80 x 8	42	2.0	0
3.0	0.40 - 3.5	1.02 x 0.88 x 8	42	3.0	0

*Within working pressure range

TECHNET™ AS 16 120

Catalog number: **17708** - (any of bellow 6 digits)

FLOW RATE (L/H)	DISTANCE BETWEEN DRIPPERS (M)																
	0.30	0.40	0.50	1.00	0.30	0.40	0.50	1.00	0.30	0.40	0.50	1.00	0.30	0.40	0.50	1.00	
1.0					001500												
1.6																	
2.0							003650										
3.0																	
Bundled coil length (meter)	50	50	50	50	100	100	100	100	200	200	200	200	400	400	400	400	

Missing catalog numbers available upon request

DRIPPERLINE TECHNICAL DATA

MODEL	INSIDE DIAMETER (MM)	WALL THICKNESS (MM)	OUTSIDE DIAMETER (MM)	MAX. WORKING PRESSURE (BAR)	KD
16 120	14.20	1.20	16.60	4.0	0.72

DRIPPERLINES PACKAGE DATA

MODEL	COIL LENGTH (METER)	DISTANCE BETWEEN DRIPPERS (METER)	AVERAGE COIL WEIGHT (KG)	COILS IN A 40 FEET CONTAINER (UNITS)	TOTAL IN A 40 FEET CONTAINER (METERS)	COILS IN A 20 FEET CONTAINER (UNITS)	TOTAL IN A 20 FEET CONTAINER (METERS)
16 120	50	0.20 to 1.00	2.7	1440	72000	720	36000
	100		5.5	960	96000	480	48000
	200		11.0	480	96000	240	48000
	400		22.0	352	140800	176	70400

TECHNET™ AS 16 100

Catalog number: **17678** - (any of bellow 6 digits)

FLOW RATE (L/H)	DISTANCE BETWEEN DRIPPERS (M)															
	0.30	0.40	0.50	1.00	0.30	0.40	0.50	1.00	0.30	0.40	0.50	1.00	0.30	0.40	0.50	1.00
1.0																
1.6					004400										004700	
2.0			006180			006100	006200						005950	006120	006220	
3.0													007000			
Bundled coil length (meter)	50	50	50	50	100	100	100	100	200	200	200	200	500	500	500	500

Missing catalog numbers available upon request

DRIPPERLINE TECHNICAL DATA

MODEL	INSIDE DIAMETER (MM)	WALL THICKNESS (MM)	OUTSIDE DIAMETER (MM)	MAX. WORKING PRESSURE (BAR)	KD
16 100	14.20	1.00	16.20	3.5	0.72

DRIPPERLINES PACKAGE DATA

MODEL	COIL LENGTH (METER)	DISTANCE BETWEEN DRIPPERS (METER)	AVERAGE COIL WEIGHT (KG)	COILS IN A 40 FEET CONTAINER (UNITS)	TOTAL IN A 40 FEET CONTAINER (METERS)	COILS IN A 20 FEET CONTAINER (UNITS)	TOTAL IN A 20 FEET CONTAINER (METERS)
16 100	50	0.20 to 1.00	3.2	1440	72000	720	36000
	100		6.5	960	96000	480	48000
	200		12.5	480	96000	240	48000
	500		24.9	352	176000	176	88000





LANDLINE™ 12 AND 16

ON-SURFACE TURBUNEXT™ FLOW



APPLICATIONS

- On-surface installation.
- Shrubs, flower beds and vegetable gardens.
- Under mulch.
- For relative flat irrigation zones.
- For narrow planting areas.

FEATURES AND BENEFITS

- Large, efficient TurbuNext™ flow path.
- Easy installation.
- Tubing flexibility adapts to any shape of planting area.
- UV-resistant dripperline.
- Long lasting reliability and durability.
- Colored dark brown.

SPECIFICATIONS

- Dripper flow rates: 1.0, 2.0, 3.0, 4.0 l/h (nominal flow rate at 1.0 bar pressure).
- Maximum operation pressure: 3.5 bar.
- Recommended filtration: 130 micron / 120 mesh.
- Landline™ 12, ID = 10.2 mm.
- Landline™ 16, ID = 14.2 mm.

DRIPPERS TECHNICAL DATA

FLOW RATE* (L/H)	MAXIMUM WORKING PRESSURE** (BAR)	WATER PASSAGES DIMENSIONS WIDTH-DEPTH-LENGTH (MM)	FILTRATION AREA (MM²)	CONSTANT K	EXPONENT X
1.00	4.0/3.5	0.60 x 0.74 x 65	45	0.347	0.46
1.50	4.0/3.5	0.71 x 0.85 x 65	48	0.468	0.46
2.00	4.0/3.5	0.76 x 1.03 x 65	51	0.693	0.46
3.00	4.0/3.5	0.90 x 1.20 x 65	51	1.040	0.46
4.00	4.0/3.5	0.94 x 1.28 x 33	51	1.387	0.46

*Flow rate at 1.0 bar pressure **According to dripperlines inside diameter

DRIPPERLINE TECHNICAL DATA

MODEL	INSIDE DIAMETER (MM)	WALL THICKNESS (MM)	OUTSIDE DIAMETER (MM)	MAX. WORKING PRESSURE (BAR)	KD
Landline™ 12	10.30	1.00	12.30	3.5	0.7
Landline™ 16	14.20	1.00	16.20	3.5	0.4

LANDLINE™ 12 (DARK BROWN)

Catalog number **16060** - (any of bellow 6 digits)

FLOW RATE (L/H)	DISTANCE BETWEEN DRIPPER (M)	COIL LENGTH (M)		
		25	50	100
1.00	0.20	006000	006050	006100
	0.50	006450	006500	006550
2.00	0.30			
	0.50			
3.00	0.30			
	0.50			
4.00	0.30			
	0.50			

Missing catalog numbers available upon request

DRIPPERLINES PACKAGE DATA

MODEL	COIL LENGTH (METER)	DISTANCE BETWEEN DRIPPERS (METER)	AVERAGE COIL WEIGHT (KG)	COILS IN A 40 FEET CONTAINER (UNITS)	TOTAL IN A 40 FEET CONTAINER (METERS)	COILS IN A 20 FEET CONTAINER (UNITS)	TOTAL IN A 20 FEET CONTAINER (METERS)
Landline™ 12	25	0.20 to 1.00	1.0	3800	95000	1900	47500
	50		2.1	2800	140000	1400	70000
	100		4.1	2000	200000	1000	100000

LANDLINE™ 16 (DARK BROWN)

Catalog number **16065** - (any of bellow 6 digits)

FLOW RATE (L/H)	DISTANCE BETWEEN DRIPPERS (M)	COIL LENGTH (M)		
		25	50	100
1.00	0.30	002000	002050	002100
	0.50	004000	004050	004100
1.50	0.30	004300	004305	004306
	0.50	004320	004321	004322
2.00	0.30	005000	005050	005100
	0.50	005300	005350	005360
3.00	0.30			
	0.50			
4.00	0.30	006000	006050	006060
	0.50	006200	006250	006260

Missing catalog numbers available upon request

DRIPPERLINES PACKAGE DATA

MODEL	COIL LENGTH (METER)	DISTANCE BETWEEN DRIPPERS (METER)	AVERAGE COIL WEIGHT (KG)	COILS IN A 40 FEET CONTAINER (UNITS)	TOTAL IN A 40 FEET CONTAINER (METERS)	COILS IN A 20 FEET CONTAINER (UNITS)	TOTAL IN A 20 FEET CONTAINER (METERS)
Landline™ 16	25	0.20 to 1.00	1.2	1920	48000	960	24000
	50		2.3	1440	72000	720	36000
	100		4.6	900	90000	450	45000



LANDLINE™ 8

ON-SURFACE TURBONET™ FLOW



APPLICATIONS

- On-surface installation.
- Shrubs, flower beds and vegetable gardens.
- Short laterals length.
- For flat irrigation zones.
- Narrow planting areas.

FEATURES AND BENEFITS

- Large, efficient TurboNet™ flow path.
- Easy installation.
- Tubing flexibility adapts to any shape of planting area.
- UV-resistant dripperline.
- Long lasting reliability and durability.
- Colored brown or dark brown.

SPECIFICATIONS

- Dripper flow rate: 2.0 l/h (nominal flow rate at 1.0 bar pressure).
- Maximum operation pressure: 4.0 bar.
- Recommended filtration: 130 micron / 120 mesh.
- Use Landline™ 8 mm fittings.

DRIPPERS TECHNICAL DATA

FLOW RATE* (L/H)	MAX. WORKING PRESSURE (BAR)	WATER PASSAGES DIMENSIONS WIDTH-DEPTH-LENGTH (MM)	FILTRATION AREA (MM²)	CONSTANT K	EXPONENT X
2.0	4.0	0.63 x 0.73 x 22	22	0.647	0.49

*Nominal flow rate at 1.0 bar pressure

DRIPPERLINES TECHNICAL DATA

MODEL	INSIDE DIAMETER (MM)	WALL THICKNESS (MM)	OUTSIDE DIAMETER (MM)	MAX. WORKING PRESSURE (BAR)	KD
Landline™ 8	6.30	0.80	7.90	4.0	2.0

LANDLINE™ 8

Catalog number **18500** - (any of bellow 6 digits)

FLOW RATE (L/H)	DISTANCE BETWEEN DRIPPER (M)	COIL LENGTH (M)					
		30	50	100	200	300	600
2.00	0.15	002860	002862	002865	002867	002870	
	0.20	002880				002890	002895
	0.30	002920	002919	002922	002923	002925	002927
	0.50	002940				002945	002936

Missing catalog numbers available upon request

Blank tube , without drippers inside, 30 meter coil: 18500-001050

LANDLINE™ 8 (DARK BROWN)

Catalog number **18500** - (any of bellow 6 digits)

FLOW RATE (L/H)	DISTANCE BETWEEN DRIPPER (M)	COIL LENGTH (M)		
		30	50	100
2.00	0.15	003719		
	0.20			
	0.30	003750	003760	
	0.50			

Missing catalog numbers available upon request

DRIPPERLINES PACKAGE DATA

WALL THICKNESS (MM)	COIL LENGTH (METER)	DISTANCE BETWEEN DRIPPERS (METER)	AVERAGE COIL WEIGHT (KG)
0.80	30	0.15 to 0.50	0.6
	50	0.15 to 0.50	1.0
	100	0.15 to 0.50	2.0



TECHFLOW™ JUNIOR

PRESSURE-COMPENSATING, CONTINUOUSLY SELF-CLEANING
ON-LINE DRIPPER



APPLICATIONS

- Slopes and high wind areas.
- Shrubs, trees irrigation.
- Curved, narrow and unshaped planting areas.
- Roof gardens.
- Planters, pots, baskets.

FEATURES AND BENEFITS

PRESSURE COMPENSATING

- Precise and equal amounts of water are delivered over a broad pressure range.
- 100% uniformity of water and nutrients distribution along the laterals.

CONTINUOUS SELF-FLUSHING DRIPPER DESIGN

- Flushes debris as it is detected, throughout operation, not just at the beginning or end of a cycle, ensuring uninterrupted dripper operation.

ANTI-SIPHON MECHANISM

- Anti-Siphon mechanism prevents contaminants from being drawn into the dripper.

OPTIONAL CNL MODEL, 0.12 BAR CHECK VALVE IN EACH DRIPPER

- All drippers turn on and off at the same time, maximizing balance of application. System holds back up to 1.2 m of water (elevation change). No low emitter drainage, great on slopes. Delivers more precise watering.

IN-LINE MODEL

- Special model, fit 4 mm micro-tube as distribution tube. Dripper with dual barb, inlet and outlet for In-line installation.

PCJ SP (SELF-PIERCING) DRIPPER

- Requiring no pre punching when installed on pipes class 2.5 and 4.0.
- Number of drippers can be raised to increase water quantity supply and meet the tree's growth rate requirements

SPECIFICATIONS

- Flow rates: 2.0, 4.0, 8.0 l/h.
- Pressure compensating range: 0.7 to 4.0 bar.
- Anti-siphon mechanism.
- Optional, In-line model.
- Optional, model CNL: Anti-drain mechanism, shut-off pressure: 0.12 bar.
- Optional, model SP (self-piercing).
- Recommended filtration: 130 micron / 120 mesh.

DRIPPERS TECHNICAL DATA

FLOW RATE* (L/H)	WORKING PRESSURE RANGE (BAR)	WATER PASSAGES DIMENSIONS WIDTH-DEPTH-LENGTH (MM)	FILTRATION AREA (MM ²)	CONSTANT K	EXPONENT* X
2.0	0.7 - 4.0	0.98 x 0.79 x 35	2.0	2.0	0
4.0	0.7 - 4.0	1.32 x 0.92 x 35	2.0	4.0	0
8.0	0.7 - 4.0	1.60 x 1.08 x 35	2.0	8.0	0

*Within working pressure range

TECHFLOW™ JUNIOR DRIPPER - 3 MM BARB OUTLET

Catalog number **21520** - (any of bellow 6 digits)

FLOW RATE (L/H)	1 UNIT	50 UNITS/BAG	100 UNITS/BAG
2.0	002100	002120	002130
4.0	002500	002520	002530
8.0	002700	002720	

Missing catalog numbers available upon request



IN LINE TECHFLOW™ JUNIOR DRIPPER - 3 MM BARB OUTLET

Catalog number **21600** - (any of bellow 6 digits)

FLOW RATE (L/H)	1 UNIT	10 UNITS/BAG	50 UNITS/BAG
1.2	002995		
2.0	003100	003350	003600
4.0	003200	003400	003700
8.0	003200	003400	003700



IN LINE TECHFLOW™ JUNIOR CNL DRIPPER - 3 MM BARB OUTLET

Catalog number **21600** - (any of bellow 6 digits)

FLOW RATE (L/H)	1 UNIT	10 UNITS/BAG	50 UNITS/BAG	100 UNITS/BAG
0.5	001778			
1.2	001780			
2.0	001800	001810	001815	001820
3.0	001900		001920	
4.0	002000	002010	002015	002020
8.0	002100	002110	002120	

PCJ-SP (SELF-PIERCING) DRIPPER - 3 MM BARB OUTLET

Catalog number **21500** - (any of bellow 6 digits)

NOMINAL FLOW RATE (L/H)	1 UNIT	10 UNITS/BAG	50 UNITS/BAG	100 UNITS/BAG
2.0	004000	004030	004040	004050
4.0	004100	004130	004140	004150
8.0	004200	004220	004230	004250

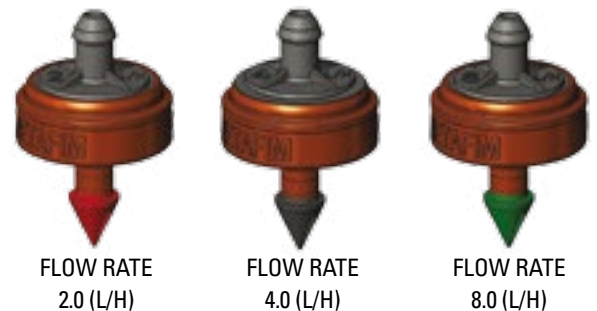



LEACH LINE A™

INTEGRAL DRIPPER



APPLICATIONS

- Heap Leaching for copper, gold and silver mines.

FEATURES AND BENEFITS

- Superior TurbuNext™ flow regime.
- Wide and deep flow path cross-section to minimize clogging and ensure exact flow rate in all working conditions.
- Large filtration area for optimal performance, even with suspended solids solutions.
- Internal emitter protected against mechanical damage.
- Injected molded drippers ensure high uniformity and very low CV.

SPECIFICATIONS

- Broadest choice of dripper flow rates: 1.0, 1.5, 2.0, 3.0, 4.0 l/h.
- Max. working pressure: 3.0 / 3.5 bar (according to dripperlines wall thickness).
- Recommended filtration: 130 micron / 120 mesh.

DRIPPERS TECHNICAL DATA

FLOW RATE* (L/H)	MAXIMUM WORKING PRESSURE** (BAR)	WATER PASSAGES DIMENSIONS WIDTH-DEPTH-LENGTH (MM)	FILTRATION AREA (MM²)	CONSTANT K	EXPONENT X
1.0	3.0 / 3.5	0.60 x 0.74 x 65	45	0.347	0.46
1.5	3.0 / 3.5	0.71 x 0.85 x 65	48	0.520	0.46
2.0	3.0 / 3.5	0.76 x 1.03 x 65	51	0.693	0.46
3.0	3.0 / 3.5	0.90 x 1.20 x 65	51	1.040	0.46
4.0	3.0 / 3.5	0.94 x 1.28 x 33	51	1.387	0.46
8.0	3.0 / 3.5	1.52 x 1.28 x 28	50	2.773	0.46

* Nominal flow rate at 1.0 bar pressure. **According to dripperline wall thickness.

LEACH LINE A™ 16009

Catalog number : **12315** - (any of bellow 6 digits)

FLOW RATE (L/H)	DISTANCE BETWEEN DRIPPERS (M)													
	0.15	0.20	0.25	0.30	0.35	0.40	0.50	0.60	0.65	0.70	0.75	0.80	0.90	1.00
1.00					000200									
1.50														
2.00							003000							
3.00														
4.00								005000						
8.00														
Bundled coil length (meter)	500	500	500	500	500	500	500	500	500	500	500	500	500	500

Missing catalog numbers available upon request

DRIPPERLINE TECHNICAL DATA

MODEL	INSIDE DIAMETER (MM)	WALL THICKNESS (MM)	OUTSIDE DIAMETER (MM)	MAX. WORKING PRESSURE (BAR)	MAX. FLUSHING PRESSURE (BAR)	KD
16009	14.20	0.90	16.00	3.0	3.9	0.4

DRIPPERLINES PACKAGE DATA (ON BUNDLED COILS)

MODEL	WALL THICKNESS (MM)	DISTANCE BETWEEN DRIPPERS (METER)	COIL LENGTH (METER)	AVERAGE* COIL WEIGHT (KG)	COILS IN A 40 FEET CONTAINER (UNITS)	TOTAL IN A 40 FEET CONTAINER (METERS)
16009	0.90	0.2 to 1.00	500	20.7	330	165000

*According to drippers spacing

LEACH LINE A™ 16010

Catalog number : **12308** - (any of bellow 6 digits)

FLOW RATE (L/H)	DISTANCE BETWEEN DRIPPERS (M)													
	0.15	0.20	0.25	0.30	0.35	0.40	0.50	0.60	0.65	0.70	0.75	0.80	0.90	1.00
1.00														
1.50							001846		001856					
2.00				001990		002010	002050							
3.00														
4.00								005310	005320					
8.00														
Bundled coil length (meter)	500	500	500	500	500	500	500	500	500	500	500	500	500	500

Missing catalog numbers available upon request

DRIPPERLINE TECHNICAL DATA

MODEL	INSIDE DIAMETER (MM)	WALL THICKNESS (MM)	OUTSIDE DIAMETER (MM)	MAX. WORKING PRESSURE (BAR)	MAX. FLUSHING PRESSURE (BAR)	KD
16010	14.20	1.00	16.20	3.5	4.6	0.4

DRIPPERLINES PACKAGE DATA (ON BUNDLED COILS)

MODEL	WALL THICKNESS (MM)	DISTANCE BETWEEN DRIPPERS (METER)	COIL LENGTH (METER)	AVERAGE* COIL WEIGHT (KG)	COILS IN A 40 FEET CONTAINER (UNITS)	TOTAL IN A 40 FEET CONTAINER (METERS)
16010	1.00	0.2 to 1.00	500	23.0	330	165000

*According to drippers spacing

